

Installation and operating instructions for Hydraulic power unit HCO2R type

E 09.796e



RINGSPANN GmbH

Schaberweg 30-38
61348 Bad Homburg
Germany

Phone +49 6172 275 0
Fax +49 6172 275 275

www.ringspann.com
info@ringspann.com

RINGSPANN	Installation and operating instructions for Hydraulic power unit HCO2R type	E 09.796e			
Issue: 06.04.2022	Version: 1	Drawn: BAHS	Checked: EISF	Pages: 32	Page: 2

Important

Please read these instructions carefully before installing and operating the product. Your particular attention is drawn to the notes on safety.

These installation and operating instructions are valid on condition that the product meets the selection criteria for its proper use. Selection and design of the product is not the subject of these installation and operating instructions.

Disregarding or misinterpreting these installation and operating instructions invalidates any product liability or guarantee by RINGSPANN; the same applies if the product is taken apart or changed.

These installation and operating instructions should be kept in a safe place and should accompany the product if it is passed on to others -either on its own or as part of a machine- to make it accessible to the user.

Safety Notice

- Installation and operation of this product should only be carried out by skilled personnel.
- Repairs may only be carried out by the manufacturer or accredited RINGSPANN agents.
- If a malfunction is indicated, the product or the machine into which it is installed, should be stopped immediately and either RINGSPANN or an accredited RINGSPANN agent should be informed.
- Switch off the power supply before commencing work on electrical components.
- Rotating machine elements must be protected by the purchaser to prevent accidental contact.
- Supplies abroad are subject to the safety laws prevailing in those countries.

This is a translation of the German original version!

In case of inconsistencies between the German and English version of this installation and operating instruction, the German version shall prevail.

RINGSPANN	Installation and operating instructions for Hydraulic power unit HCO2R type	E 09.796e			
Issue: 06.04.2022	Version: 1	Drawn: BAHS	Checked: EISF	Pages: 32	Page: 3

CONTENTS

- 1 GENERAL**
 - 1.1 TECHNICAL CHARACTERISTICS
 - 1.2 CONSTITUENT PARTS
- 2 FUNCTIONS**
 - 2.1 Normal operation “electric mode”
 - 2.2 Redundant return solenoid valve (optional)
 - 2.3 Standby pump “manual mode”
 - 2.4 Pressure filter
 - 2.5 Electric oil level indicator (optional)
 - 2.6 Oil temperature control (optional)
 - 2.7 Immersion heater (optional)
 - 2.8 Flow limiter (optional)
 - 2.9 Flow control valve & Secure lowering (optional)
 - 2.10 Air conditioner filter (optional)
- 3 INSTALLATION**
 - 3.1 Delivery condition
 - 3.2 Layout
 - 3.3 Piping
 - 3.4 Filling the tank
 - 3.5 Electrical connection
- 4 INITIAL START UP**
- 5 PERIODIC MAINTENANCE**
- 6 MAINTENANCE**
 - 6.1 Draining/filling
 - 6.2 Adjusting the pressure limiter
 - 6.3 Adjusting the pressure switch
 - 6.4 Checking the pressure of the accumulators
- 7 SPARE PARTS**
- 8 STORAGE**
- 9 TROUBLESHOOTING**
- 10 REFERENCE DRAWING**

RINGSPANN	Installation and operating instructions for Hydraulic power unit HCO2R type			E 09.796e	
Issue: 06.04.2022	Version: 1	Drawn: BAHS	Checked: EISF	Pages: 32	Page: 4

1 GENERAL

HCO2R type compact hydraulic power unit are used to open hydraulic safety brakes by pressurizing the circuit.

This power unit can manage the brakes in two different modes:

- **Electric mode** In “electric” mode, a motor gear pump unit integrated into the tank pressurizes the hydraulic circuit of the brakes.
- **Manual mode.** (optional) In “manual” mode, actuating a hand pump connected to the power unit's tank using a lever pressurizes the hydraulic circuit of the brakes.



Life-threatening danger!

Disc must be absolutely degreased before all contact with the brakes linings.

In case of lining pollution with grease, the nominal brake force is not guaranteed.

**The power units are fail safe components.
All setting and repairs must be performed by skilled operators.**

The oil temperature must never exceed 80°C.

When assembling, operating and maintaining the brake it is to be ensured that the entire drive train is secured against being switched on unintentionally. Moving parts can cause severe injury. Rotating parts (e.g. brake disc) must be secured by the operator against unintentional touching.

Strongly pre-loaded pressure springs are installed in the springed thrusters of the brake. The spring thruster may only be disassembled by the factory.

1.1 TECHNICAL CHARACTERISTICS

There is a type plate on the power unit with a 16-digit article number. The exact design of the power unit is defined by this article number only.

		Standard	Optional Code HCO2R OPMP055-2	Optional Code HCO2R OPMP15-3,7	Optional Code HCO2R OPMP15-2
Max. pressure	bar	230	120	230	180
Flow rate	l/min	250	140	250	200
Motor power	kW	1.3	2.4	3.7	2.4

Rated voltage	: 400 V 3-phase – 50Hz
Tank volume	: 2.5 L
Maximum service volume	: 2.0 L
Max. admissible contamination rate acc. to NAS 1638	: 10
Ambient temperature	: - 20 to + 40°C
Ingress protection	: IP 55
Mounting form	: horizontal
Oil connection thread	: 3/8"

As well as these instructions, please also consider the catalogue data for the power unit at www.ringspann.com and the drawings in the individual sections.

1.2 CONSTITUENT PARTS

HCO2R-type compact power packs are available in different configurations:

Code containing =>	HCO2R 12704 01	HCO2R 12704 02	HCO2R 12704 03
1 Medium-pressure generator	X	X	X
1 Function unit manifold	X	X	X
1 Electric control box	X	X	X
1 pressure filter unit		X	
1 lever hand pump unit*			X

- Hand pump can be deported.

As well as these instructions, please also consider the catalogue data for the power unit at www.ringspann.com and the drawings in the individual sections.

1.2.1 MOTOR PUMP UNIT

This generator is composed of a 3-phase 4 poles motor, which drives a gear pump, and a metal tank, all fitted around the flange. The tank is equipped with a gauge, a breather valve and a drain plug (located on the side of the flange).

	<p>Important!</p> <p>The oil temperature must never exceed 80°C.</p>
---	--

1.2.2 THE FUNCTION UNIT

The hydraulic function unit is directly fixed to the side of the flange at the pump output. It controls the circulation of oil between the tank, the pump and the actuator connected to the power unit.

Optional accumulators: 32 and 75 cl accumulators, together with a backup hand pump, are available as options.

1.2.3 THE ELECTRIC CABINET

The electric cabinet that controls the motor and the solenoid valve is attached to the tank.



Fig. 1.1

Note: In case the power unit is integrated into a brake, the cabinet can be fixed on the caliper bracket sometimes.

2 FUNCTIONS

2.1 Normal operation "Electric control mode"

When the unit is powered, the pump rotates and pushes the oil flow through the non-return valve. Voltage must be supplied to solenoid valves **1D** and **2D** for preventing the oil returning to the tank, and allowing the pressure in the circuit to rise. When the threshold **1SP** pressure switch is reached, the motor is stopped and the non-return valve prevents the oil from passing back through the pump, maintaining the pressure in the circuit. When the power unit is fitted with accumulators, these can remain pressurised thanks to pressure switch **2D**, even when no voltage is supplied to the power unit. When voltage is supplied to the power unit, the accumulators can then quickly discharge into the circuit, and the pump only starts up when the pressure drops under the low threshold of pressure switch **1SP**.

Hydraulic diagram (with optional hand pump unit PAM):

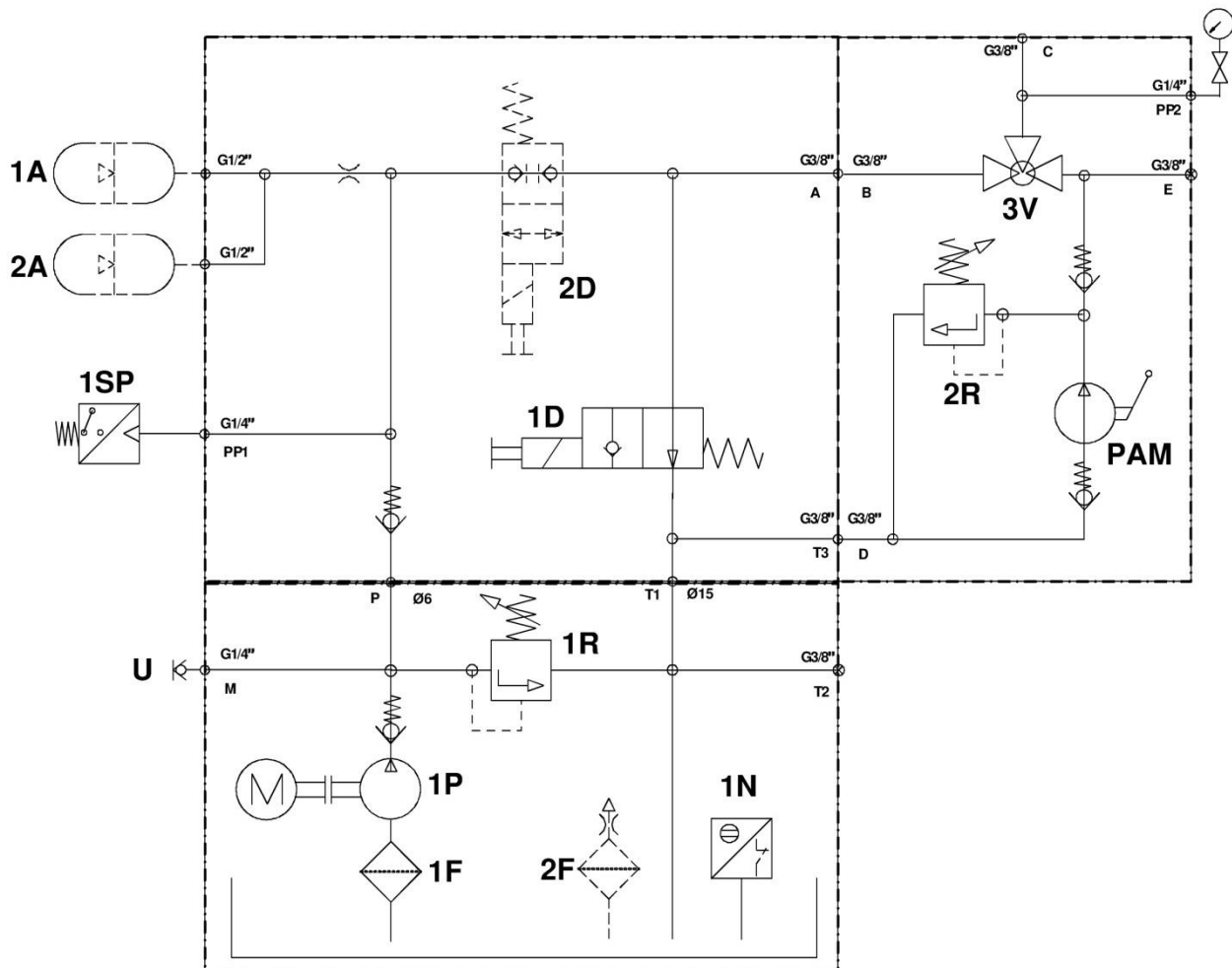

Fig. 2.1

2.2 Redundant return solenoid valve (optional)

The power unit can be optionally equipped with a solenoid valve **1Db** mounted on a parallel piping (energized by the same supply than 1D and 2D).

Solenoid valve **1Db** is a redundancy of **1D**.

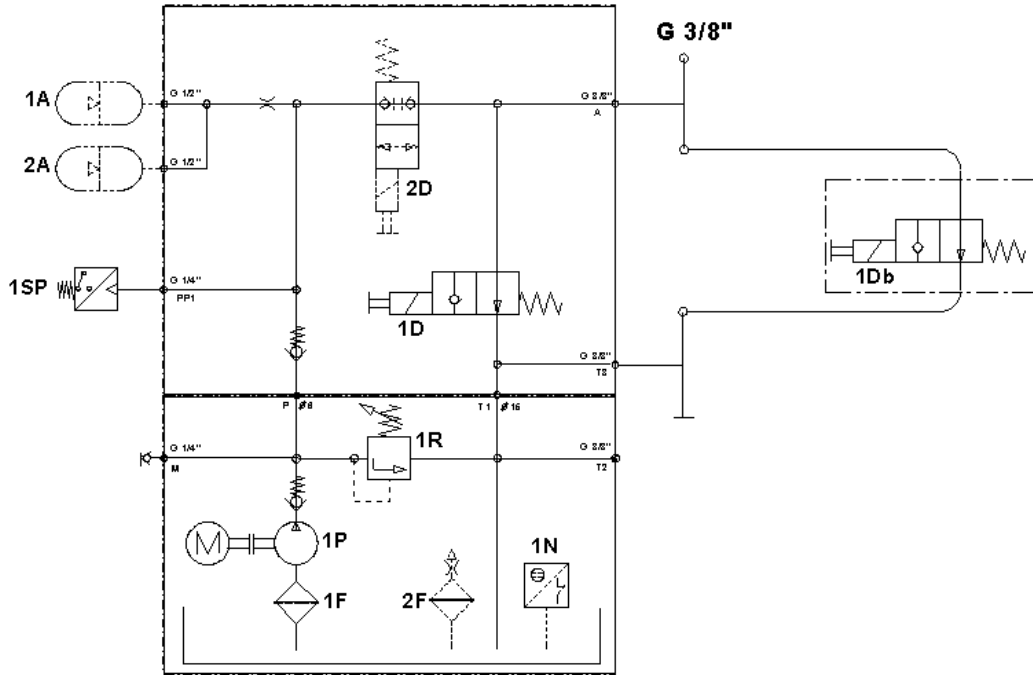

Fig. 2.2

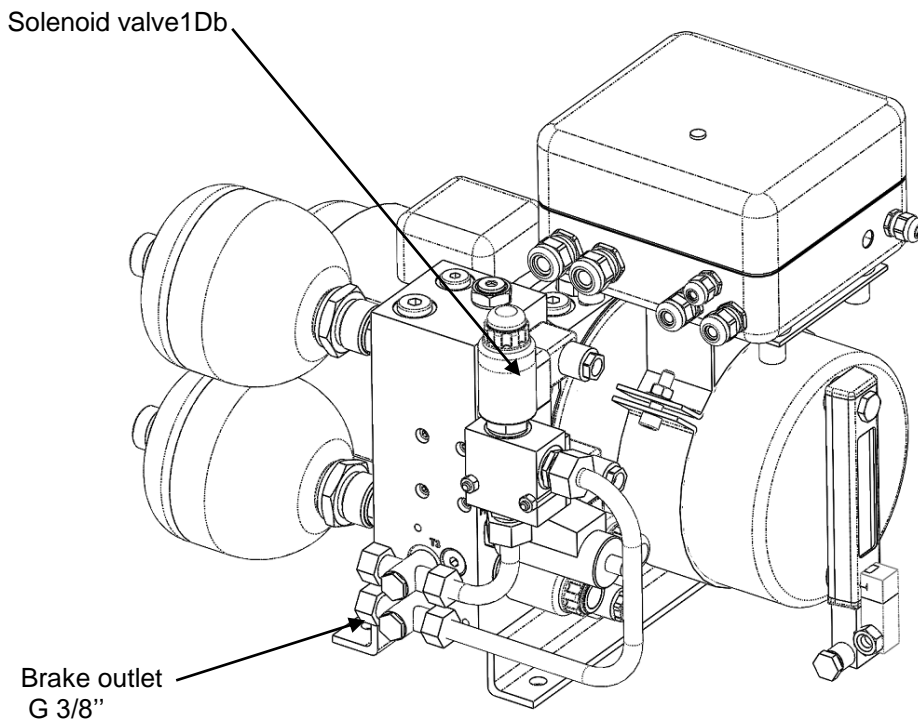



Fig. 2.3

2.3 Standby pump “manual mode”

The hand pump option comprises a unit including:

	<p>Important!</p> <p>Close the isolation valve when in operation to prevent any damage to the pressure gauge.</p>
---	---

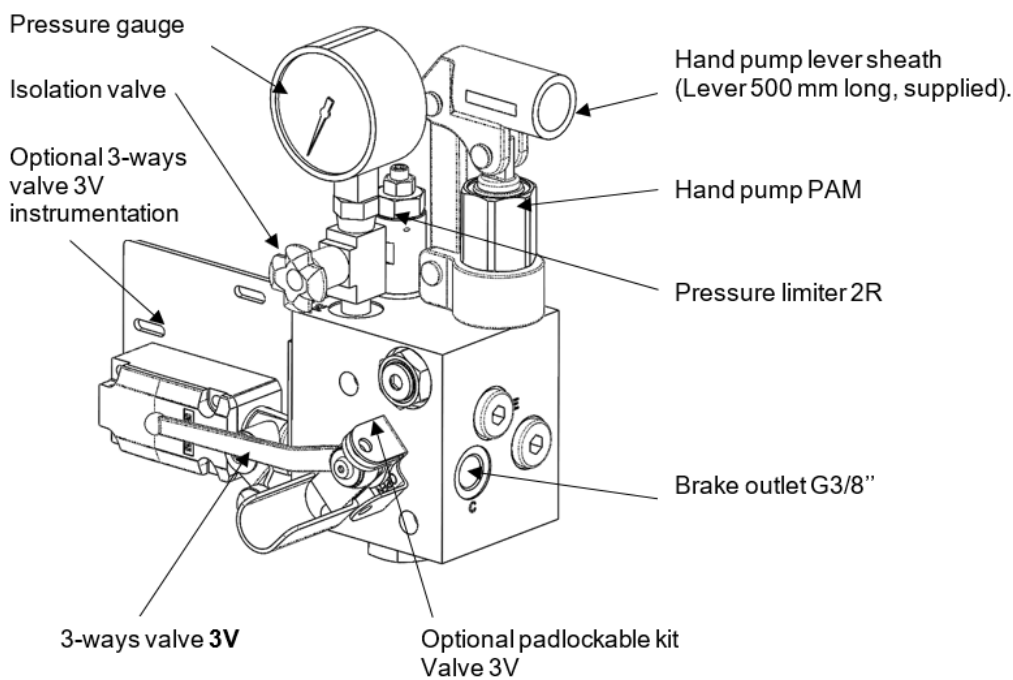

Fig. 2.4

Two configurations are available for hand pump option:

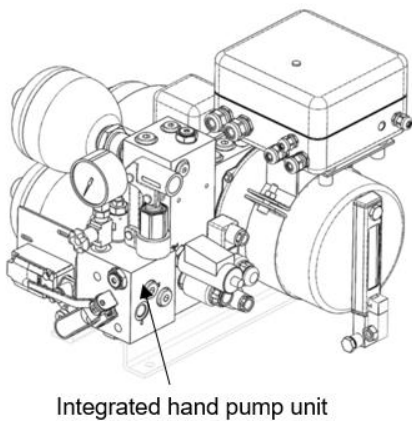

Fig. 2.5

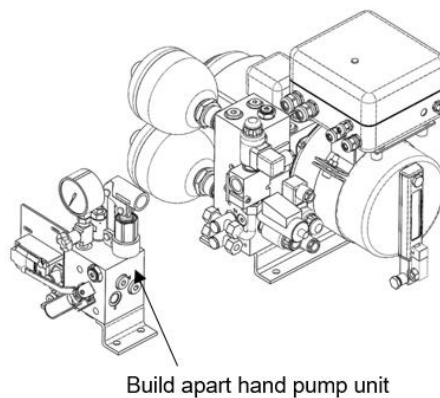

Fig. 2.6

To open the caliper manually, isolate the “electric mode” circuit of the power unit by switching the 3-way valve **3V** to “manual mode” hand pump
Place the supplied lever in the hand pump coupling and operate the pump.

The brakes open after a few runs. Gradually closing the 3-way valve **3V** causes the pressure to drop (the brake closes).
The hand pump is provided with an integrated factory-calibrated adjustable pressure limiter.
A pressure gauge indicates the pressure during pumping.

2.4 Pressure filter

The pressure filter option consists of a block that can be flanged onto the main block of the power unit comprising a pressure filter (filter fineness 20 µm).

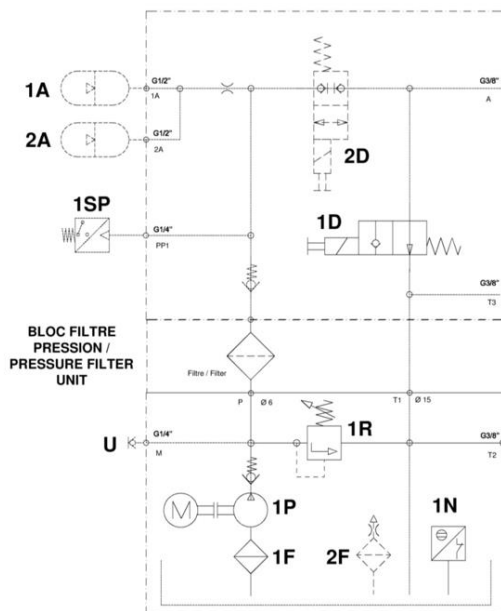

Fig. 2.7

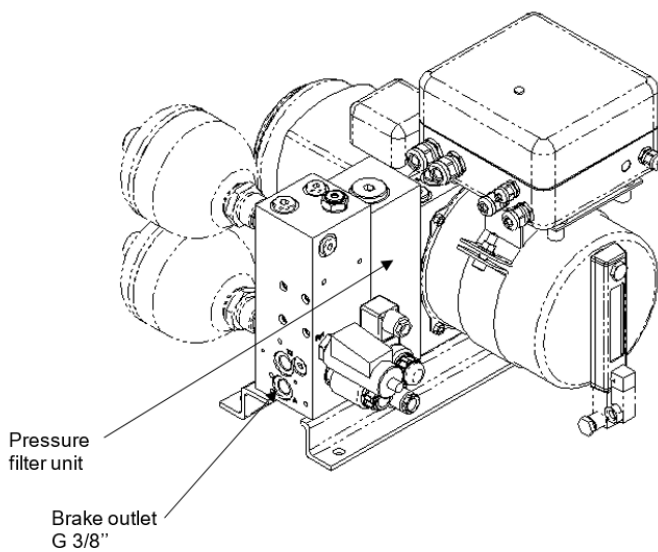

Fig. 2.8

2.5 Electrical oil level indicator (optional)

Code OPTION: HCO2R OPNIV ELE

An electrical switch, in combination with the gauge glass **1N** will be activated as soon as the oil level in the power unit tank reaches the min level.

Switch open, closed at min. level
Protection IP65

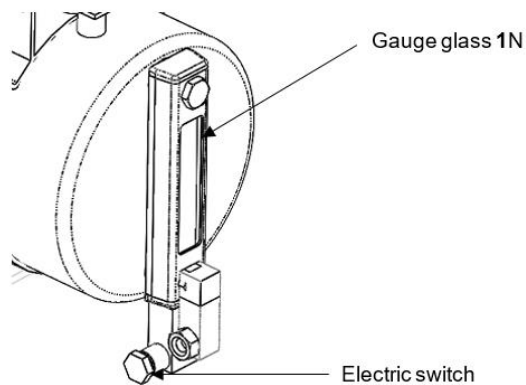

Fig. 2.9

2.6 Oil temperatur control (optional)

Code OPTION: HCO2R OPTHERMO

A thermosth, in combination with the gauge glass **H**, will be activated when the oil temperature in the power unit tank overshoots.

- Switching according to the principle of normally closed.
- Activation temperature: 70°C +/-5°

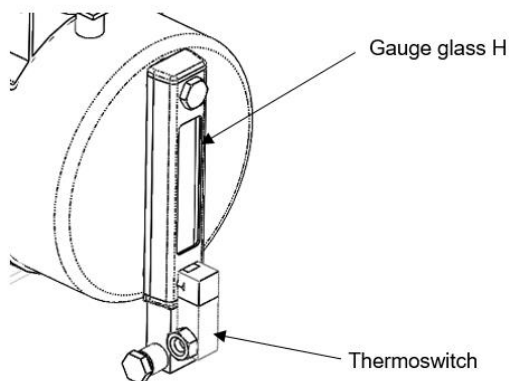

Fig. 2.10

2.7 Immersion heater (optional)

Code OPTION: HCO2R OPTHPLO

The immersion heater **1T** heats the oil in the power unit tank.
An oil circulation system ensures a constant temperature throughout the hydraulic circuit.
An adjustable thermostat in the electric cabinet controls the start and stop of the heating.

Characteristics:

Power: 200 W

Voltage: 230 Volts

Adjustment range: 0 to 40 C°

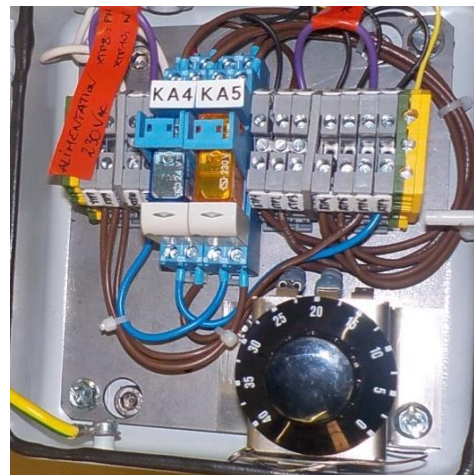

Fig. 2.11

Fig. 2.12



Information!

The thermostat is factory-set by default to 0°C.

Electric diagram:

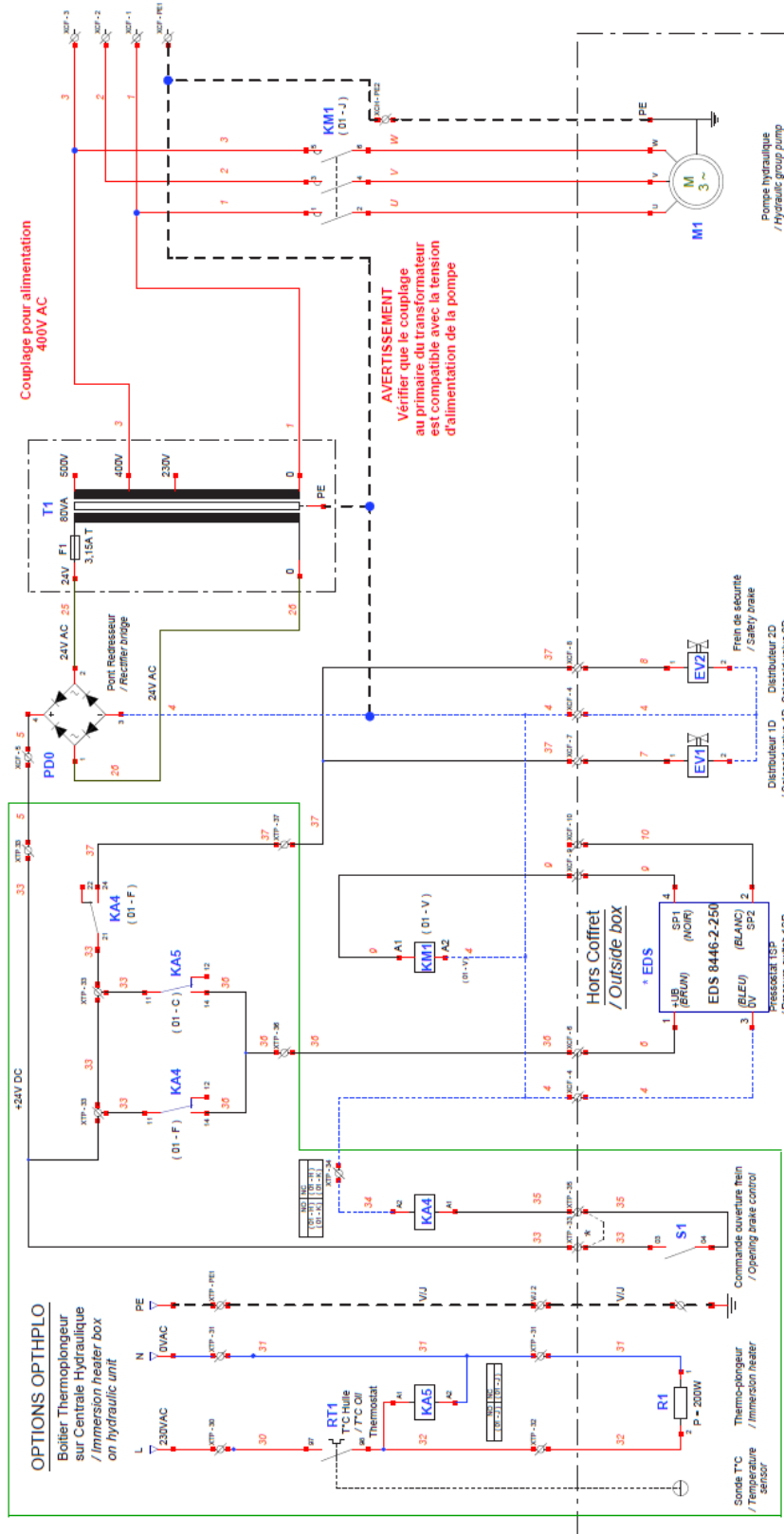

Fig. 2.13

2.8 Flow limiter (optional)

Code OPTION: HCO2R OPLIM02

The power pack may be equipped with a flow limiter 1L which delays the brake closing time in manual and electric modes.

The flow limiter 1L is sealed by a protective tube, and is connected to the oil outlet (brake oil flow pipe).

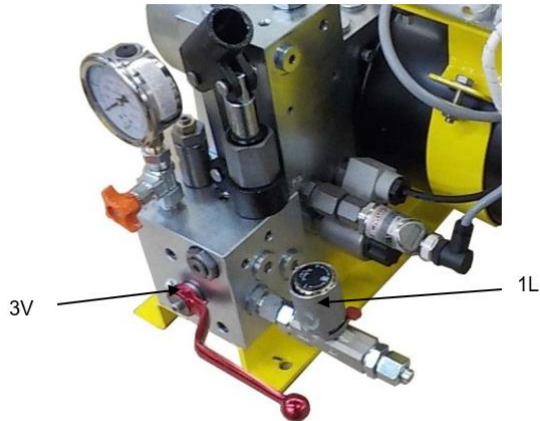
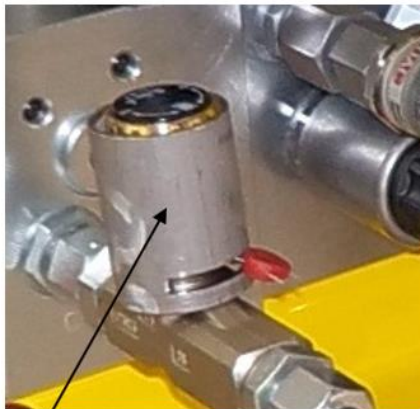



Fig. 2.14



Protective tube

Fig. 2.15

	<p>Important!</p> <p>THE FLOW LIMITER IS FACTORY-SET BEFORE DELIVERY. THE CUSTOMER DOES NOT NEED TO ADJUST OR MODIFY ANYTHING.</p>
---	--

	<p>Information!</p> <p>The braking closing time is set at 6-7 seconds. For a different setting, please contact first ATV.</p>
---	--

	<p>DANGER!</p> <p>THE COMPLETE CLOSING OF THE FLOW LIMITER MAY SHUT OFF THE BRAKING FUNCTION BY Blocking THE OIL RETURNING BACKFLOW TO THE TANK.</p>
---	--

2.9 Optional Flow control valve Secure lowering

Item code OPTION "Flow control valve": **HCO2R OPLIM01**

Item code OPTION "Secure lowering": **HCO2R OP AFF SEC**

Note: both options are independently available

The option 'Flow control valve' is made of a throttle valve which is piped parallel to the hand pump. This throttle valve enables the use of the hand pump to control the brake force and thus makes a load lowering possible.

The optional 'secure lowering' is made of a poppet valve which is piped parallel to the hand pump. This valve is to be supplied with 24V. It may be controlled by an encoder and a speed supervision module.

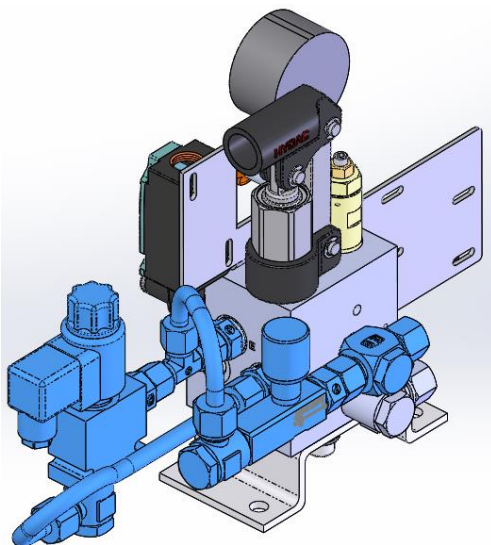

Fig. 2.16

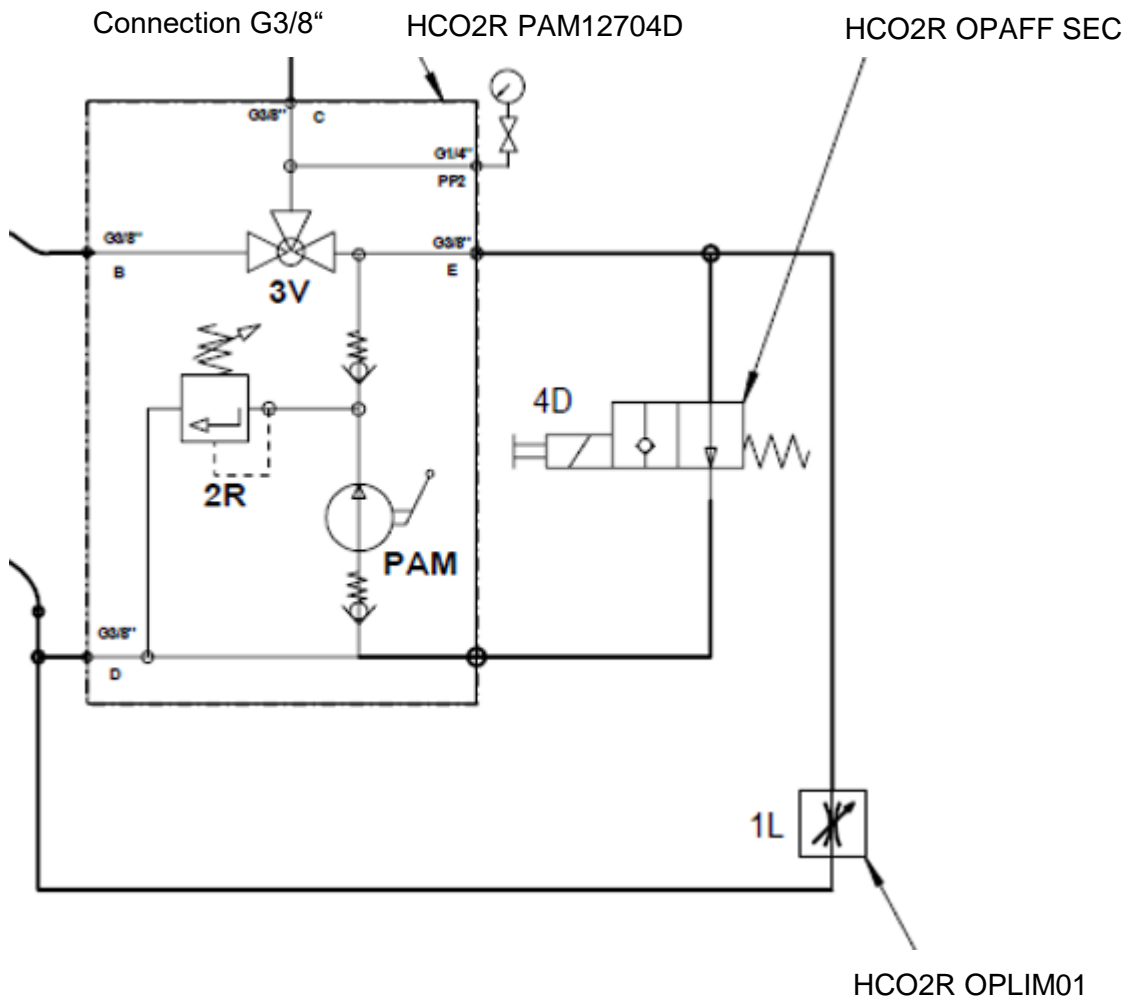



Fig. 2.17

	<p>Important!</p> <p>THE FLOW CONTROL VALVE IS FACTORY SET. CUSTOMER MAY NOT MODIFY ITS SETTING.</p>
---	--

2.10 Air conditioner filter (optional)

Item Code OPTION: **HCO2R OPFILAIR**

This filter absorbs moisture that is formed in the hydraulic circuit thus avoiding condensation and thereby reduces the oxidation of the oil.

Moisture absorption can be observed by the colour of the indicator pellets (Z-R salts) contained in the transparent filter body. They turn to ruby red (active) to light orange (saturated).

The filter **3F** is attached to the unit of the power unit and replaces the fill plug **2F**.

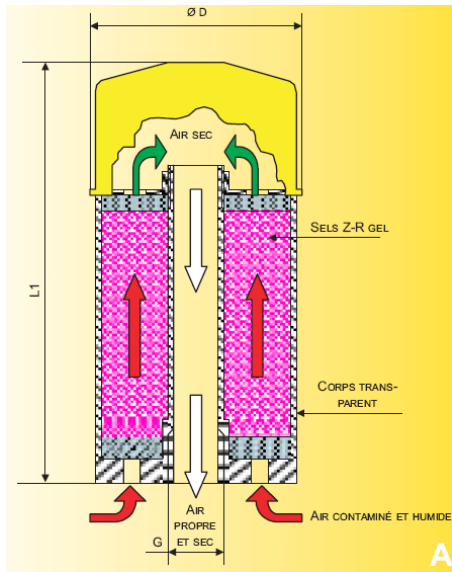

Fig. 2.18



Fig. 2.19

RINGSPANN	Installation and operating instructions for Hydraulic power unit HCO2R type	E 09.796e			
Issue: 06.04.2022	Version: 1	Drawn: BAHS	Checked: EISF	Pages: 32	Page: 18

3 INSTALLATION



Important!

EACH POWER UNIT IS SET AND TESTED AT THE FACTORY BEFORE DELIVERY; THE CUSTOMER DOES NOT NEED TO ADJUST OR MODIFY THE FUNCTION UNIT.

MODIFYING THESE SETTINGS WILL VOID THE MANUFACTURER'S WARRANTY.

3.1 Delivery condition

The power unit is delivered:

- Oil tank empty. (With oil can depending on request).
- Pressure switch **1SP** thresholds set depending on the application.
- With hand pump unit + integrated or separate lever (optional assembly).
- Flow limiter **1L** set (Flow limiter option).
- Immersion heater **1T** wired and set depending on the application (optional).
- Sets of fittings and hoses depending on the application.

3.2 Layout

The power unit must remain in a horizontal position, the axis of the cylindrical tank parallel to the floor and the level perpendicular to the floor.

Protect the generator from dust, moisture, splashing, etc.

Allow adequate ventilation for heat dissipation.

The flatness required for the mounting surface is 0.3/100 mm.

It is fixed in the flange by 4 holes $\varnothing 11$, centre distance 193 mm or 283 mm *

Tooling: Flat or socket wrench 13 mm A/F



Important!

In case the operating space of the hand pump lever is insufficient, the hand pump may be separate from the power unit. (Contact RINGSPANN for more details).

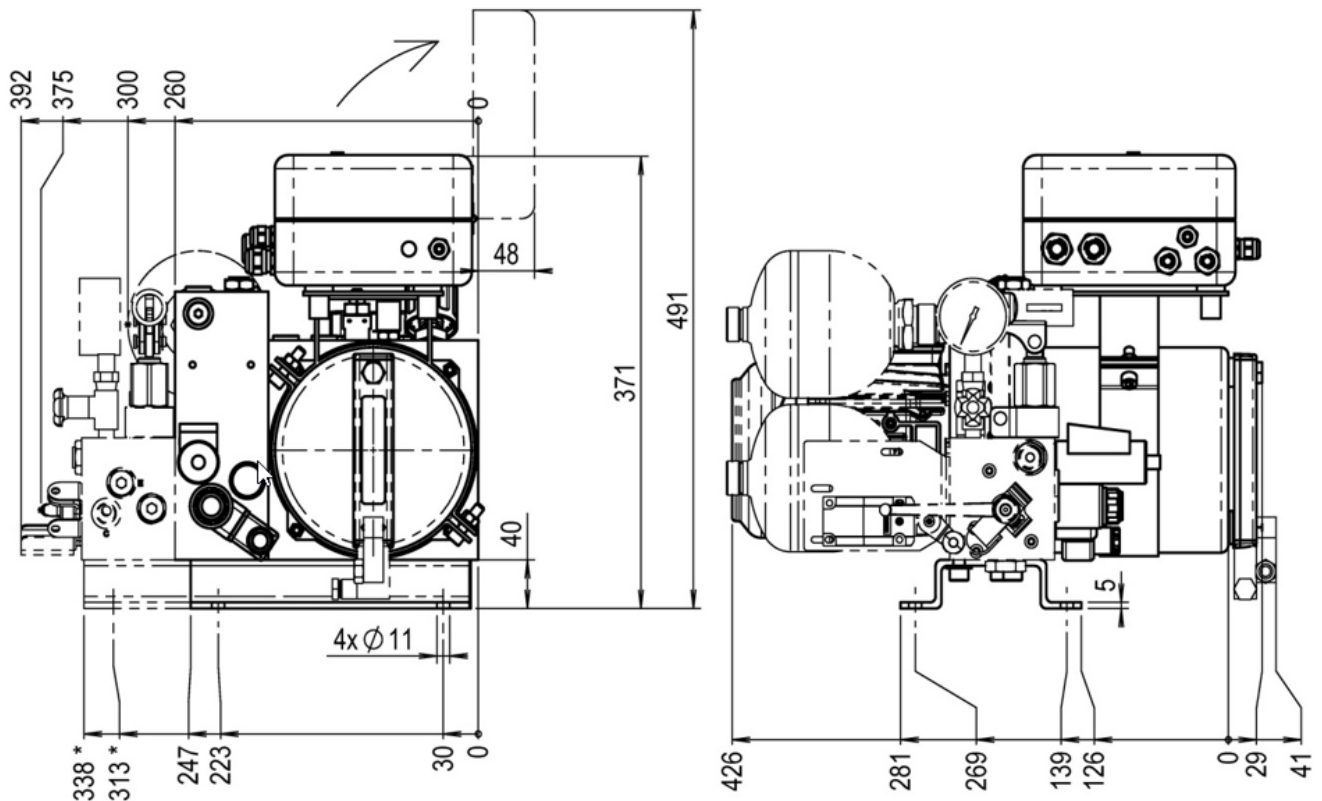

Fig. 3.1

(*) Measurement with pressure filter unit or hand pump unit

3.3 Piping

The circuit must be thoroughly cleaned inside. The examination should be performed before filling the powerunit.

Clean the pipes, screw connections and receivers (dirt, scale, sand, weld seams, chips, etc.) linking the power unit to the brake(s). Insofar as possible, strip the welded pipes and check them individually.

Without integrated hand pump:

Connect the hydraulic power unit to the brake(s) on the outlet **A** of the function unit (G 3/8" female BSP).

With integrated or separate hand pump:

Connect the hydraulic power unit to the brake(s) on the outlet **C** of the function unit (G 3/8" female BSP). In case of optional flow limiter **1L** (as per chapter 2.8), remove the screw plug in the flow limiter body and plug the hose into the G3/8" female port.

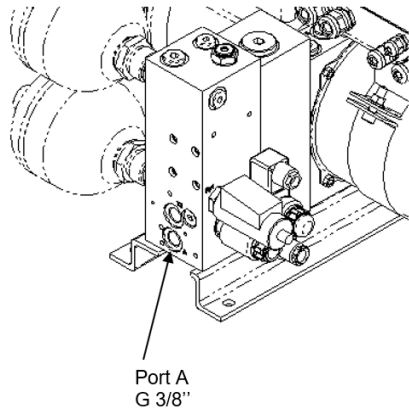

Fig. 3.2

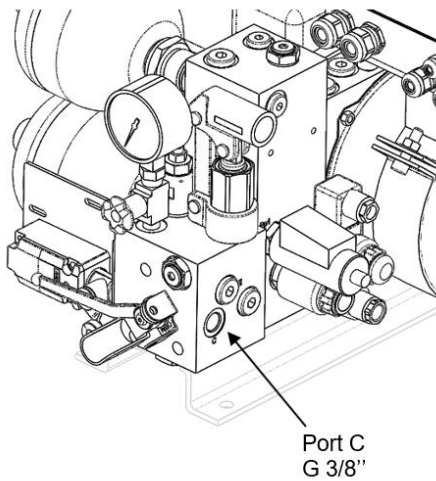





Fig. 3.3

	<p>Important!</p> <p>Never use hemp, putty, Teflon, etc. for the piping</p>
---	---

Place the lines and pipes such that they are free from stress and secure them so as to avoid oscillations. The connection to the actuator must be flexible and must respect the tightening torques recommended for screw connections.

	<p>Important!</p> <p>If Brakes are supplied with the power unit connected mechanically and hydraulically. Connection therefore means simply connecting the electric power supply.</p>
---	--

3.4 Filling the tank

	<p>Important!</p> <p>This oil must be clean maximum permitted level of pollution as per NAS 1638: 10µm.</p> <p>Use only new fluid and never mix several types all brands of fluid.</p>
---	---

Procedure:

- Check the cleanliness of the filling filter.
- Ensure perfect cleanliness when filling.
- Fill the tank via the filler cap **2F** through a fine filter, filter fineness 10µm absolute, or using a filtration unit, up to the maximum level.

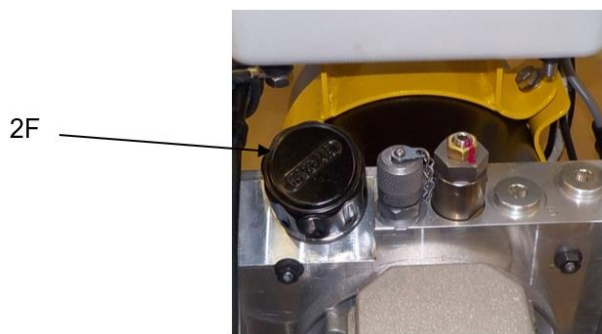



Fig. 3.4

For an ambient temperature range from 0 through 60°C, recommended oil is ISO HM32. By instance, RINGSPANN uses FUCHS RENOLIN EXTRA 32S.

Outside of the above temperature range, the viscosity shall be between 12 and 100mm²/s with a possibility to extend this range from 10 thru. 400mm²/s in case of exceptional use.

In case of low temperatures, an immersion heater may be placed in the power pack tank (Immersion heater option).

	<p>Information!</p> <p>If the power unit is equipped with an air conditioner filter 3F, it must be removed for the filling.</p>
---	---

3.5 Electrical connection

3.5.1 Cabinet on hydraulic power unit

In the electrical cabinet, route a 3-wire + earth cable (min. cross-section 1.5 mm²) via the ISO20 cable gland (clamping capacity \varnothing 6 to 13 mm).

Connect the three phases and earth to the appropriate terminal.

Remember that two of the phases are likely to be reversed upon start-up, to ensure the correct direction of rotation of the motor.

The motor has an output of 550 W. The entire circuit must be protected upstream by 2 A motor-protection fuses.



Fig. 3.5

Electric diagram:

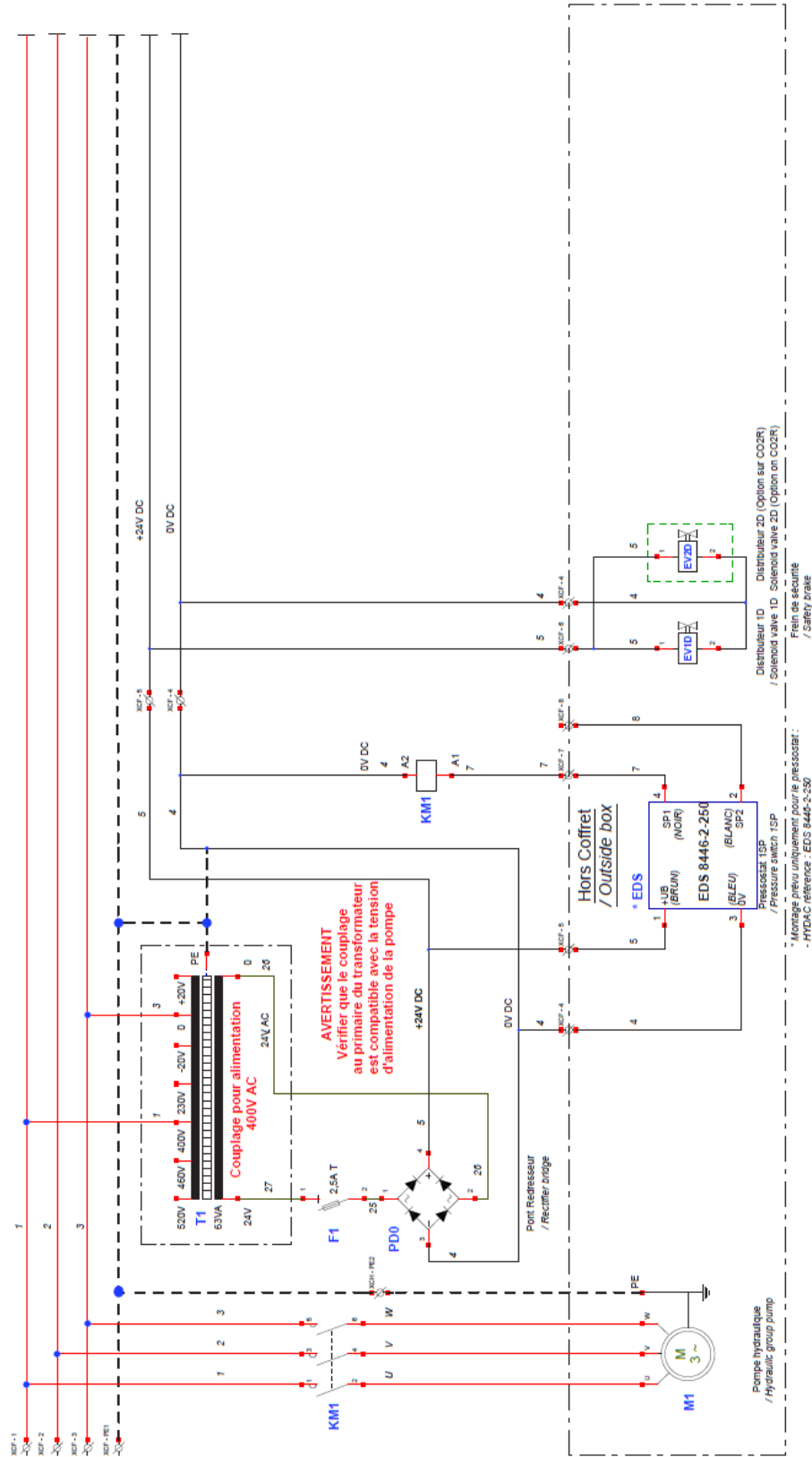

Fig. 3.6

RINGSPANN	Installation and operating instructions for Hydraulic power unit HCO2R type	E 09.796e			
Issue: 06.04.2022	Version: 1	Drawn: BAHS	Checked: EISF	Pages: 32	Page: 24

4 INITIAL START-UP

1. Bleed the hydraulic circuit Bleeding should be done successively with the hand pump.
2. Switch on the power unit.
3. When the pressure reaches the upper threshold setting of the pressure switch **1SP**, the motor must stop not later than 5 to 10 seconds of operation.
If the motor does not stop, cut off the power supply and reverse two of the supply wires at the terminal and repeat the previous operation.
4. Check that the brakes are open.

In satisfactory operating conditions, the motor must stop quickly after a start-up; check that the operation is normal by performing a few runs. In case of problem, refer to chapter 9.

5. Bleed the hydraulic circuit

Refer to the manual of the brakes for bleeding them.

Bleeding should be done successively with the motor and then with the hand pump if necessary. Top up in the power unit (see chapter 3.4).



Important!

Bleed the hydraulic circuit refer also to the manual of the brakes for bleeding them.

5 PERIODIC MAINTENANCE

The following points must be checked:

At initial start-up:

- Check all functions
- Oil level adjustment.

1 week after initial start-up:

- Check all functions.
- Oil level check.
- Check for leaks.

Every month

- Check the level and re-adjust
- Visually check the fittings and hoses, tighten if necessary.
- Check the pressure using the pressure gauge.
- Clean the motor ventilation.

Every year

- Replace oil in the power unit.
- Carry out a complete cleaning.
- Check pressure of accumulators.

Every 2 years

- Replace the solenoid valve.

Every 5 years

- Replace the electric pump.
- Replace the manual pump.
- Replace the tank seals.



Important!

ACCUMULATORS: These devices always remain under pressure, do not dismantle. The charging pressure must be checked regularly at least once a year. During maintenance work on the system, the accumulator must first be deflated by actuating manually with the power pack out of voltage.

No machining, welding or brazing must be carried out on the accumulator shell.

6 MAINTENANCE

6.1 Draining/filling

Draining is done by unscrewing the drain plug **12**. (Male hexagon wrench 8 mm A/F). It is not necessary to remove the drain plug from the integrated hand pump. Refer to chapter 3.4 for filling or topping up.

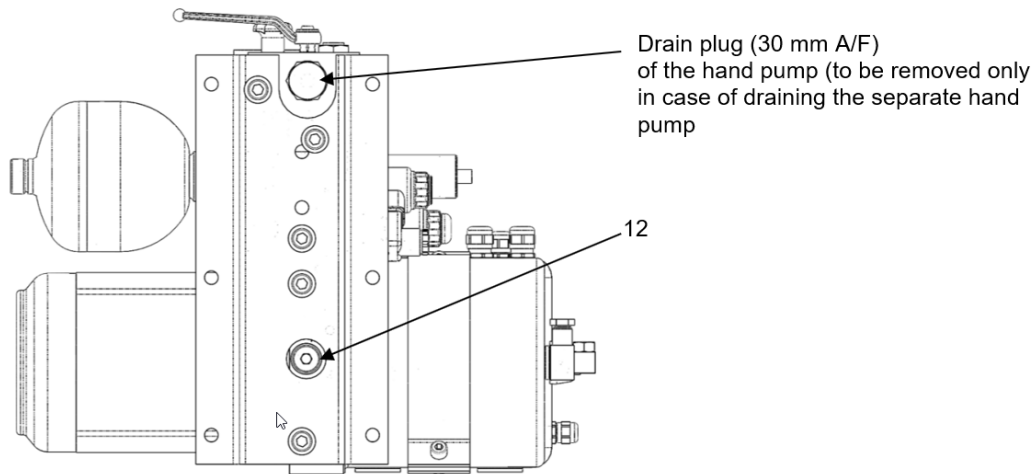

Fig. 6.1

6.2 Adjusting the pressure limiter



Important!

The limiter 1R is factory-set and does not need any adjustment. If this limiter needs to be adjusted, refer to values on the identification plate of power unit or contact RINGSPANN.

Caution: This adjustment changes the setting of the pressure switch **1SP** see Fig. 6.3.

Procedure:

- Make sure the hydraulic circuit has been bled see chapter 4.4.
- Connect a pressure gauge to the pressure tap **U**.
- Switch on the power unit.
- Adjust the upper threshold (**SP1**) of the pressure switch at the requested value for **1R** (see following section).
- Loosen the locknut of the adjustment screw **H** of the limiter **1R** (13 mm A/F).
- To increase the pressure, tighten the screw **H** (hexagon wrench 4 mm A/F) and to decrease the pressure, unscrew it.
- Increasing, the motor stops when the setting value of **1R** is the same than the upper threshold **SP1** of the pressure switch.
- Lock the locknut once the adjustment is made.
- Adjust the pressure switch as described in the following section.

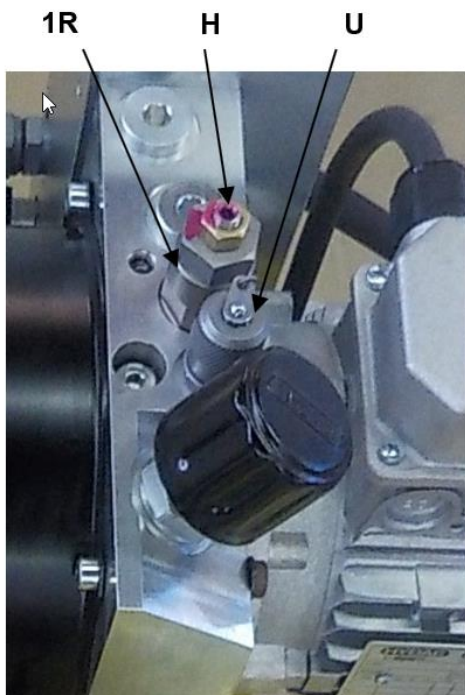



Fig 6.2

6.3 Adjusting the pressure switch



Important!

The pressure switch 1SP is factory-set and does not need any adjustment. If this limiter needs to be adjusted, refer to values on the identification plate of power unit or contact RINGSPANN.



Fig. 6.3

If this pressure switch needs to be adjusted:

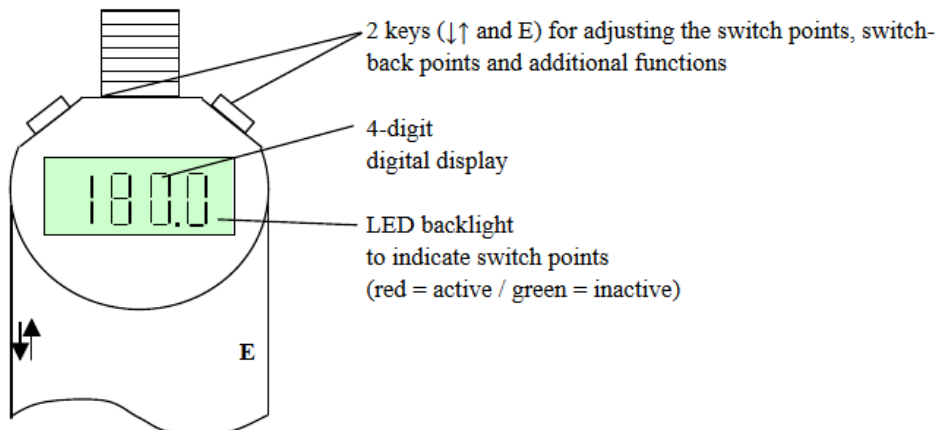

Use the keys to select the next menu point, or alternatively to adjust the values.



- To scroll through the menu
- To increase the value
- Hold the key down to fast-scroll through the parameter values



- To select the menu point
- To confirm value

Fig. 6.4

RINGSPANN	Installation and operating instructions for Hydraulic power unit HCO2R type			E 09.796e	
Issue: 06.04.2022	Version: 1	Drawn: BAHS	Checked: EISF	Pages: 32	Page: 28

Procedure:

- Ensure that the hydraulic circuit has been bled before adjusting.
- Ensure that the setting of the pressure limiter **1R** is done (see preceding section).
- Connect a pressure gauge to the pressure tap **U**.
- Switch on the power unit.
- Setting of rP1 parameter:
Select menu rP1, set the lower threshold value
- Setting of ou1 and ou2:
Select menu EF, look for submenu ou1 and switch to Hnc mode. Go to submenu ou2 and switch to Hnc as well. (This process avoids the red flashing reminders on the pressure switch).
- Setting of SP1 parameter:
Select menu SP1, set the parameter to upper threshold value needed for the brake
- In case of operating fault:
Select menu EF, then press rES and yES for reset.



Important!

This adjustment changes the setting of the pressure switch 1SP.

6.4 Checking the pressure of the accumulators

The charging pressure P_o is indicated on the nameplate on the accumulator body and should be checked regularly (at least once a year).

To check or reduce the charging pressure, it is necessary to use a charging/testing device screwed on the accumulator gas valve.



Fig. 6.5

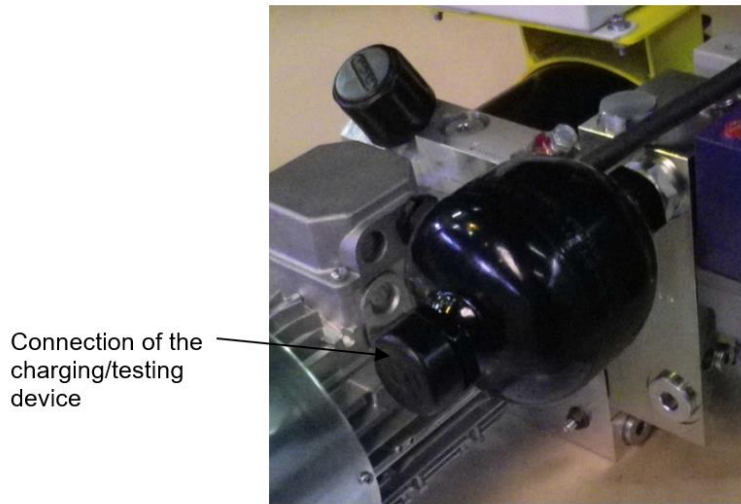

Fig. 6.6

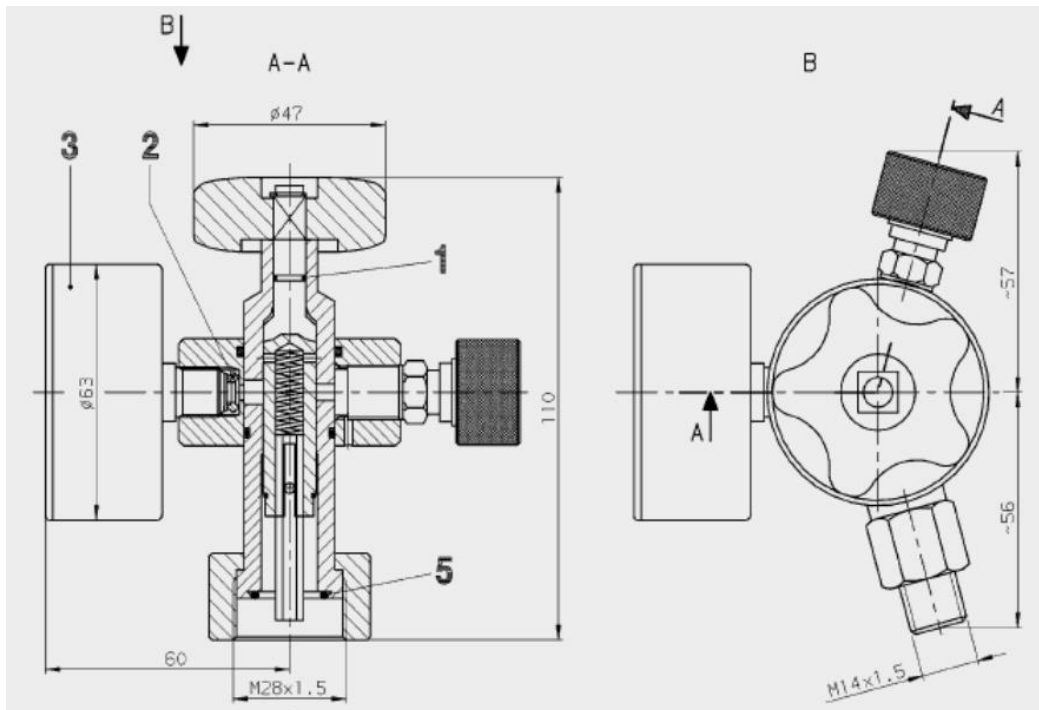

Fig. 6.7



Information!

If a recharge is necessary, connect the device to a standard nitrogen cylinder using a filling hose.

Contact RINGSPANN to order a charging device.

7 SPARE PARTS

Item number	Description	Reference
1D	Electro valve 2/2 normally open	DIS CLA WS08Y
	Coil 24 V	BOB24/3000249
2D	Electro valve 2/2 normally open	DIS CLA WS10W
	Coil 24 V	BOB24/915142
1SP	Double-threshold electronic pressure switch	PRE ELE EDS 8446
3F	Salt refill + synthetic filter kit	EFI/ACL93R

8 STORAGE

If the power unit is left inactive for more than three months, make sure the tank is full. The power unit must be stored in a dry place and must be packed in a way that protects it from dust and splashes. Suitable plugs must be inserted into the holes. The circuit will have to be bled for restarting it.



Important!

Every year, use a product such as Rustol OWATROL to prevent corrosion

9 TROUBLESHOOTING

KIND OF DEFECT	CHECK	SOLUTION
The calipers do not open in electric mode	<p>The supply voltage of the motor</p> <p>The direction of rotation of the motor</p> <p>The fluid level</p> <p>The power supply to solenoid valves</p> <p>Check the circuit pressure on the pressure gauge (13)</p>	<p>Reverse 2 phases</p> <p>Top up the level</p> <p>Calibrate the pressure limiter (1R) and adjust the thresholds of the pressure switch (1SP) chapter 6.2 and chapter 6.3</p>
The calipers do not remain open in electric mode	<p>Tightness of the hydraulic unit / piping / fittings / cylinder / piston</p> <p>The power supply to solenoid valves</p>	<p>Replace the defective element</p>
The motor does not stop when there is pressure	<p>Check the pressure switch (1SP) upper and lower thresholds</p> <p>Pressure limiter (1R)</p> <p>Tightness of the unit</p>	<p>Adjust the upper threshold and the lower threshold chapter 6.3</p> <p>Calibrate the pressure limiter chapter 6.2</p> <p>Correct the tightness</p>
The power unit starts up too often	<p>Tightness of the circuit</p> <p>Impurities allow the oil to leak out</p>	<p>Correct the tightness</p> <p>Drain and repeat the operations in chapter 3.4 and chapter 4.4</p>
The calipers open and close slowly	<p>There may be air in the circuit</p>	<p>Bleed according to chapter 4.4</p>
The calipers do not open in manual operation	<p>The position of the 3-way valve (3V)</p>	<p>Switch to manual position</p>

10 Reference drawing

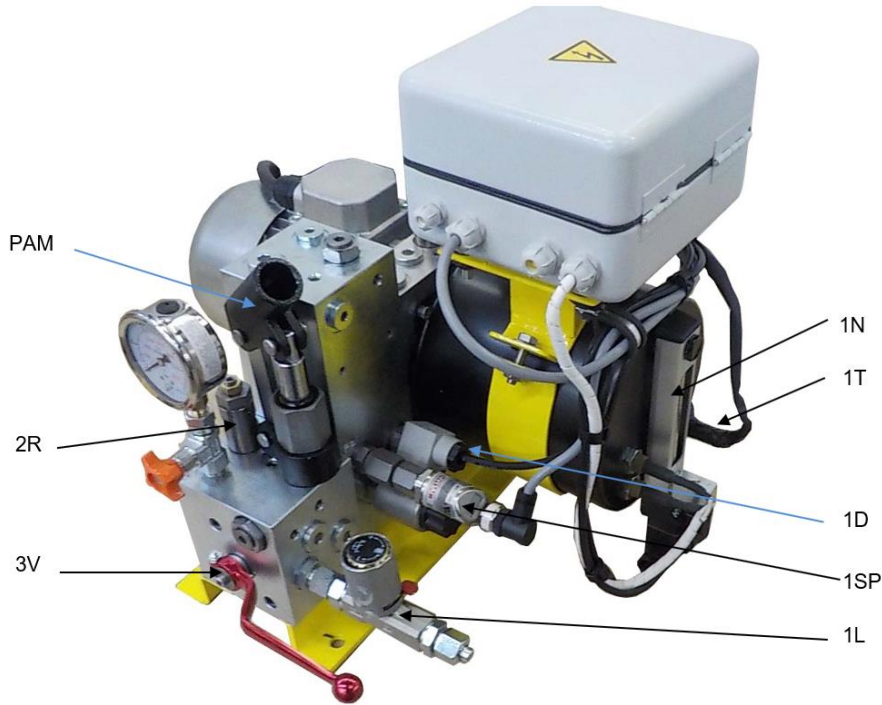

Fig. 10.1

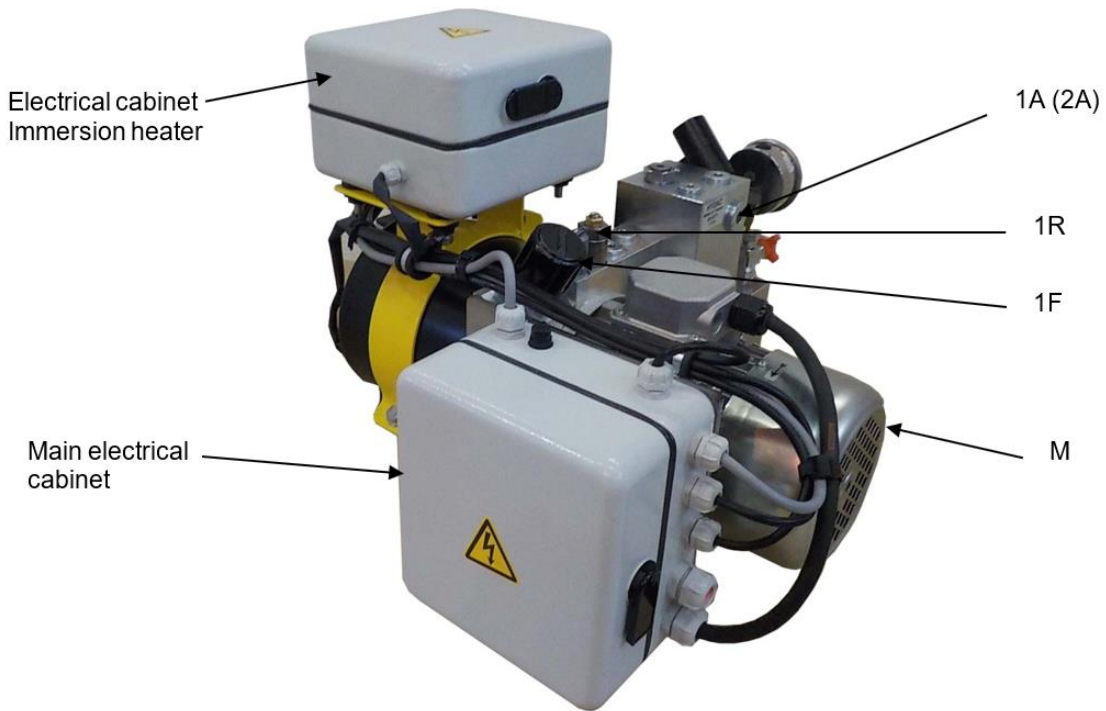

Fig. 10.2