

Shaft Couplings

Flange Couplings • Cone Clamping Couplings • Gear Couplings • Disc Couplings
Flexible Couplings • Grid Couplings • Pin and Bush Couplings • Jaw Couplings



Edition 2026/2027



Table of Contents

Shaft Coupling Introduction

Introduction

Rigid Shaft Couplings

	Nominal torques T_{KN} [Nm]	Torque load			Transmission of torque	
		uniform	not uniform	shocks, very rough operation	backlash-free	overload holding / fail safe
Tru-Line Flange-Couplings						
RFK ... TBO with backlash-free cone clamping connection	2 500 - 625 000	●●	●●	●●	●●	

Cone Clamping Couplings

RWK ... EEO with backlash-free connection of two shaft ends	130 - 7 600	●●	●●	●●	●●	
---	-------------	----	----	----	----	--

Torsionally Rigid Shaft Couplings

	Nominal torques T_{KN} [Nm]	Torque load			Transmission of torque	
		uniform	not uniform	shocks, very rough operation	backlash-free	overload holding / fail safe

Gear Couplings

RDZ ... DTO with double engagement gearing	1 330 - 391 500	●●	●●	●●		
RDZ ... DFO with single engagement gearing	1 330 - 391 500	●●	●●	●●		
RDZ ... EEO with continuous sleeve, double engagement gearing	10 - 380	●●	●●	●		

Disc Couplings

RDL ... DSO with single disc pack	96 - 18 700	●●	●●	●●	●●	
RDL ... DSZ with double disc packs with spacer	96 - 18 700	●●	●●	●●	●●	
RDL ... DSA with double disc packs, design according to API 610	96 - 18 700	●●	●●	●●	●●	

Flexible Couplings

RDA ... ESO with keyway	2 - 8 000	●●	●●	●		
RDA ... ESO with backlash-free clamping connection	2 - 32	●●	●●	●		
RDA ... ESO with mounting flange with through bores	85 - 8 000	●●	●●	●		

RDA ... ESO - Combination of hub designs

RDA ... ESO - Example hub combination

Elastic Shaft Couplings

	Nominal torques T_{KN} [Nm]	Torque load			Transmission of torque	
		uniform	not uniform	shocks, very rough operation	backlash-free	overload holding / fail safe

Grid Couplings

RES ... EYO with horizontally split cover	48 - 335 500	●●	●●	●●		
RES ... ETO with vertically split cover	48 - 169 000	●●	●●	●●		

Pin and Bush Couplings

REB ... DCO	95 - 1 299 500	●●	●●	●●		●●
REB ... DCS	2050 - 112 000	●●	●●	●●		●●

Jaw Couplings



REK ... DGO with enclosed elastic elements	34 - 7 000	●●	●●	●●		●●
REK ... DHO with enclosed elastic elements and two piece hub	160 - 7 000	●●	●●	●●		●●
REK ... DGZ with enclosed elastic elements and spacer	60 - 7 000	●●	●●	●●		●●
REK ... DCO with curved jaws	9,6 - 4 514	●●	●●	●●		●●
REK ... DCS with curved jaws	181 - 4 514	●●	●●	●●		●●

Shaft Coupling Technology Details

Technical points

Ordering information for bore in imperial dimension

Questionnaires

														Page	
														4	
Bore diameter [mm]	Installation / alignment			Permissible misalignments			Maintenance		Ambient conditions		Damping element	Atex 	Complies with		Page
	rigid / excellent	rigid / roughly	flexible	axial	radial	angular	free	low	hazardous	aggressive			API 610	API 671	
25 - 350	●●						●●				*				6
14 - 100	●●						●●				*				8
Bore diameter [mm]	Installation / alignment			Permissible misalignments			Maintenance		Ambient conditions		Damping element	Atex 	Complies with		Page
	rigid / excellent	rigid / roughly	flexible	axial	radial	angular	free	low	hazardous	aggressive			API 610	API 671	
15 - 330	●●	●	●●	●●	●●	●●		●●	●●	*		●●			10
15 - 405	●●	●	●	●●		●●		●●	●●	*		●●			12
6 - 65	●	●	●●	●●	●●	●●	●●								14
10 - 165	●●	●	●	●●		●●	●●		●●	*		●●			18
10 - 165	●●	●	●●	●●	●●	●●	●●		●●	*		●●			20
8 - 255	●●	●	●●	●●	●●	●●	●●		●●	*		●●	●●	●●	22
5 - 140	●●	●●	●●		●●	●●	●●								24
5 - 35	●●	●●	●●		●●	●●	●●								26
-	●●	●●	●●		●●	●●	●●								28
														30	
														31	
Bore diameter [mm]	Installation / alignment			Permissible misalignments			Maintenance		Ambient conditions		Damping element	Atex 	Complies with		Page
	rigid / excellent	rigid / roughly	flexible	axial	radial	angular	free	low	hazardous	aggressive			API 610	API 671	
13 - 420	●●	●	●	●●	●●	●●		●		*	●●				32
13 - 360	●●	●	●	●●	●●	●●		●		*	●●				34
15 - 600	●●	●●	●	●●	●●	●●		●	●●	*	●●	●●			36
28 - 100	●●	●●	●	●●	●●	●●		●		*	●●				40
9 - 100	●●	●	●	●●	●●	●●		●	●●	*	●●	●●			44
14 - 100	●●	●	●	●●	●●	●●		●	●●	*	●●	●●			48
9 - 100	●●	●	●	●●	●●	●●		●	●●	*	●●	●●			52
6 - 110	●●	●	●	●●	●●	●●		●	●●	*	●●	●●			56
12 - 110	●●	●●	●	●●	●●	●●		●		*	●●				64
														Page	
														70	
														73	
														76	

Key ●● true, well suited ● conditionally suitable, conditionally applicable * on request

Introduction

Couplings by RINGSPANN

For over 60 years, RINGSPANN has been renowned as a provider of couplings, beginning with the patented L-coupling from 1956, which is still offered today as model RDA ... ESO. Back then RINGSPANN was able to offer drive system engineers a compact, torsionally rigid flexible coupling based on the Oldham principle that can compensate large parallel and angular misalignments in small spaces.

RINGSPANN has since expanded its coupling range and can now offer the couplings for almost all applications.

For example, the rigid Tru-Line Flange-Couplings of the RFK ... TBO model with a special Shaft-Hub-Connection allows for freely hanging motor gear units with a torque support to be coupled to conveyor belt pulleys without fretting corrosion while accommodating significant rotating bending moment stress.

RINGSPANN offers equally suitable couplings for applications where it is critical for torque to be transmitted through a torsionally rigid connection without backlash while still being able to accommodate for shaft misalignment.

Additionally RINGSPANN can offer solutions where the torsional rigidity is beneficial for the application but needs to be adapted with the use of elastomers.

With Freewheels, Brakes, Shaft-Hub-Connections and Overload Clutches, RINGSPANN offers an exceptionally wide range of power transmission components that can be applied in drivetrains.



RFK ... TBO



RWK ... EEO



RDZ ... DTO



RDZ ... DFO



RDZ ... EEO



RDL ... DSO



RDL ... DSZ



RDL ... DSA



RDA ... ESO



RDA ... ESO



RDA ... ESO



RES ... EYO



RES ... ETO



REB ... DCO



REB ... DCS



REK ... DGO



REK ... DHO



REK ... DGZ



REK ... DCO



REK ... DCS



Features

- Compact design
- Small axial space required for installation
- Quick disassembly for minimal downtime
- Large allowable shaft tolerance of h8
- Shafts are not weakened by keyways
- No fretting corrosion like with keyway connections
- Typical applications: Drive units and conveyor drives e.g. in mining

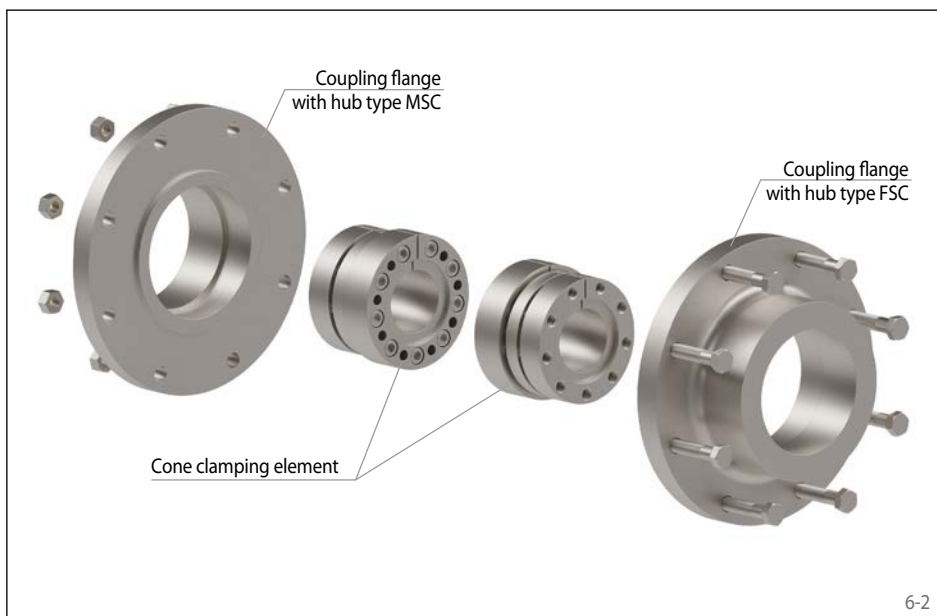

Transmissible torques

The transmissible torques listed on the following page are subject to the listed tolerances, surface finishes and material requirements. Please contact RINGSPANN in case of deviations.

Tolerances

- h8 for shaft diameters d_F or d_M

Surfaces

Average surface finish at the contact surfaces of the shafts $R_z = 10 \dots 25 \mu\text{m}$.

Materials

RINGSPANN is able to recommend suitable shaft materials using DIN 743 (12/2012 edition) taking the surface pressures for the Tru-Line Flange-Couplings RFK ... TBO into account.

Simultaneous transmission of torque, axial force and bending moment

Where there are combinations of axial forces and/or bending moments in the application in addition to the torque T_N , the max. transmissible torque will be reduced as compared to the values for $T_{K \text{ max}}$ shown in the tables.

RINGSPANN will select the proper coupling for each application based upon the allowed transmissible torque under existing bending moment conditions. Our selection calculations are in accordance with the latest scientific knowledge and experience in the industry and will include the proper safety factor to prevent fretting corrosion. Please contact RINGSPANN.

Order example

Order example	Code
Coupling design	RFK
Coupling size of smaller coupling half	0050
Type	TBO
Material of the hub:	STA
• Steel	
Hub A, type:	
• Flange with Female Pilot	F
• Flange with Male Pilot	M
Hub A, design:	SC
• Frictional Shaft-Hub-Connection	
Bore diameter d_F or d_M	025
Hub B, type:	
• Flange with Female Pilot	F
• Flange with Male Pilot	M
Hub B, design:	SC
• Frictional Shaft-Hub-Connection	
Bore diameter d_F or d_M	025

RFK 0050 TBO-STA-FSC025-MSC025

Order information

The coupling halves and the fasteners set can also be ordered separately.

The indication of the coupling half corresponds to the size of the smaller coupling half.

backlash-free cone clamping connection

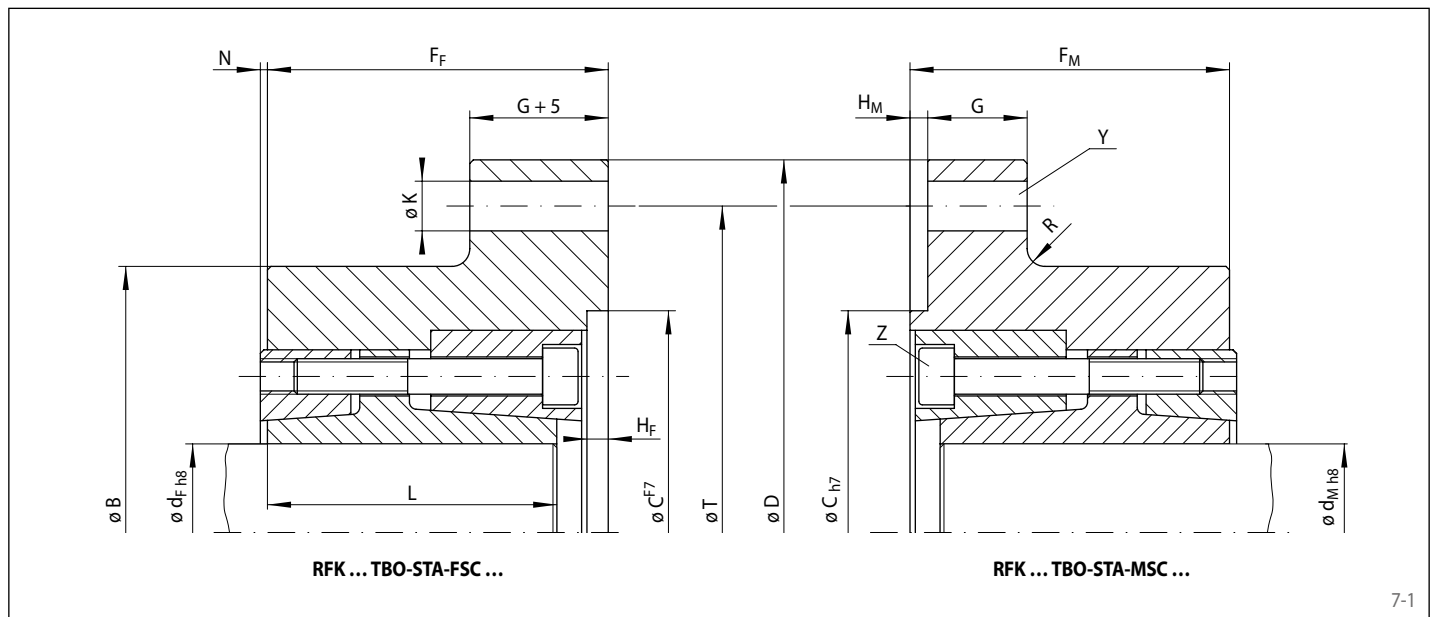

7-1

Tru-Line Flange-Coupling RFK Size		Shaft d _F or d _M mm	Max. transmissible torque T _{K max} Nm	Inertia moment at max. bore		B mm	C mm	D mm	F _F mm	F _M mm	G mm	H _F mm	H _M mm	K mm	L mm	N mm	R mm	T mm	Flange connection screws		Cone clamping screws		Weight**	
FSC Female Pilot	MSC Male Pilot			J _{KM} kgm ²	J _{KF} kgm ²														Y*	Tightening torque Nm	Z	Tightening torque Nm	FSC kg	MSC kg
0050	0050	min. 25 max. 50	2500 5250	0,0185	0,0235	120	100	190	70	65	10	5	3	11	60	3	10	160	8 x M10 x 40	71	8 x M8	42	7,3	6,4
0070	0070	min. 50 max. 70	6300 10000	0,0938	0,1126	170	150	260	86	81	15	5	3	15	75	3	15	230	8 x M14 x 60	195	9 x M10	83	17,4	15,7
0090	0090	min. 70 max. 90	16000 20000	0,285	0,327	200	180	320	105	95	25	7	5	18	90	6	15	280	8 x M16 x 75	300	9 x M12	144	31,1	28,6
0115	0115	min. 90 max. 115	28000 35500	0,739	0,847	230	300	400	115	105	30	10	6	25	100	5	40	350	8 x M24 x 100	1020	7 x M14	229	49,2	49,5
0140	0140	min. 115 max. 140	45000 56000	0,868	0,984	270	300	400	115	105	30	10	6	25	100	5	20	350	8 x M24 x 100	1020	10 x M14	229	53,8	52,8
0170	0170	min. 140 max. 170	90000 112000	3,55	3,96	330	300	560	145	135	35	12	8	32	128	8	30	480	18 x M30 x 120	2030	11 x M16	354	120	112,4
0210	0210	min. 170 max. 210	160000 200000	4,29	4,74	390	300	560	145	135	36	12	8	32	128	8	20	480	18 x M30 x 120	2030	16 x M16	354	138	126,8
0211	0211	min. 170 max. 210	160000 200000	7,16	7,88	430	350	630	145	135	40	12	8	32	128	8	20	550	18 x M30 x 130	2030	16 x M16	354	182,3	169,8
0250	0250	min. 210 max. 250	265000 315000	8,54	9,30	470	350	630	160	150	40	12	8	32	140	7	10	550	18 x M30 x 130	2030	14 x M20	692	204,9	189,2
0270	0270	min. 250 max. 270	375000 400000	13,9	15,1	510	550	710	180	170	40	12	8	32	160	8	30	630	24 x M30 x 130	2030	16 x M20	692	255,2	255,1
0290	0290	min. 270 max. 290	450000 490000	16,0	17,3	550	550	710	180	170	40	12	8	32	160	8	15	630	24 x M30 x 130	2030	19 x M20	692	276,5	272,9
0321	0321	min. 290 max. 320	520000 540000	24,2	26,1	580	550	800	200	190	45	12	8	32	180	11	15	720	28 x M30 x 150	2030	20 x M20	692	338,6	330,3
0350	0350	min. 320 max. 350	590000 625000	29,6	31,7	630	550	800	200	190	45	12	8	32	180	11	15	720	28 x M30 x 150	2030	20 x M20	692	402,7	386,9

Paired coupling halves of the same colour can be interchanged due to matching flange patterns. The maximum torques of the smaller coupling half apply.

* Number of connection screws Y in accordance DIN EN ISO 4014 property class 10.9 or 12.9 for RFK 0050 TBO on pitch circle T.

** for min. bore

Mounting

The installation and operating instruction for Tru-Line Flange-Couplings RFK ... TBO is available on request.



8-1

Features

- Compact design
- Easy to remove
- For shaft diameters ranging from 14 mm to 100 mm
- Rigid and backlash-free connections of the shaft ends
- Shafts are not weakened by keyways
- No fretting corrosion like with keyway connections
- Transmission of torque and/or axial forces
- Typical applications: Connection of shaft sections e.g. with slitter winders in the paper industry

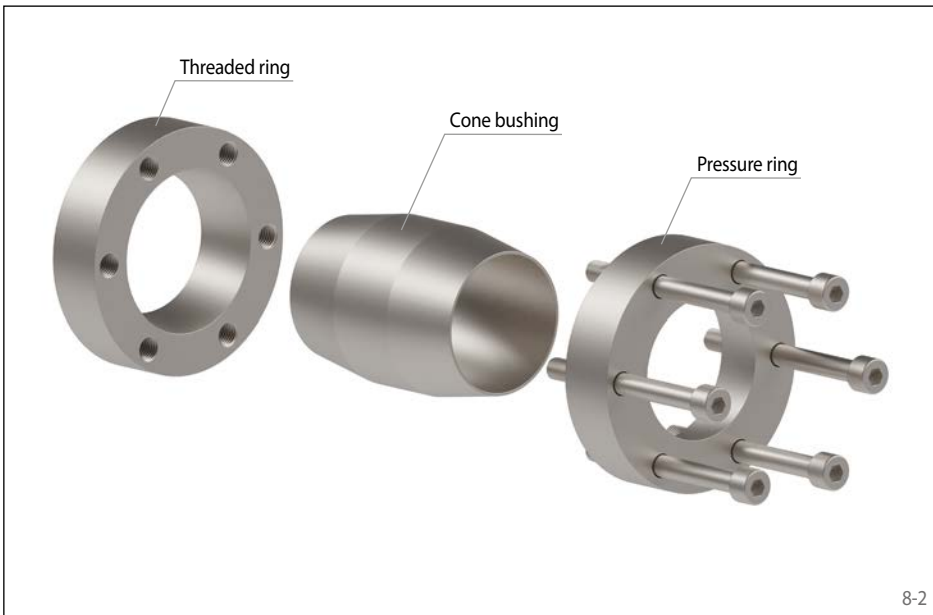

8-2

Order example

Order example	Code
Coupling design	RWK
Coupling size	0014
Type	EEO
Material of the hub: • Steel	STA
Hub, type: • 0, standard	0
Hub, design: • Clamping ring hub, clamping screws from outside	SE
Bore diameter d	014

RWK 0014 EEO-STA-0SE014

Transmissible torques and axial forces

The transmissible torques and axial forces listed on the following page are subject to the listed tolerances, surface finishes and material requirements. Please contact RINGSPANN in case of deviations.

Tolerances

- h8 for shaft diameter d

Surfaces

Average surface finish at the contact surfaces of the shafts $R_z = 10 \dots 25 \mu\text{m}$.

Materials

The following apply to the shafts:

- E-module $\geq 170 \text{ kN/mm}^2$

Simultaneous transmission of torque and axial force

The transmissible torques $T_{K \max}$ which are shown in the table apply for axial forces $F_{ax \max} = 0 \text{ kN}$ and conversely, the indicated axial forces $F_{ax \max}$ apply to torques $T_{K \max} = 0 \text{ Nm}$. If torque and axial force are to be transmitted simultaneously, the transmissible torque and the transmissible axial force are reduced.

For a given axial force $F_{AN \max}$, the reduced torque $T_{K \max r}$ is calculated as:

$$T_{K \max r} = \sqrt{T_{K \max}^2 - (F_{AN \max} \cdot \frac{d}{2})^2}$$

For a given torque $T_{N \max}$, the reduced axial force $F_{ax \max r}$ is calculated as:

$$F_{ax \max r} = \frac{2}{d} \sqrt{T_{K \max}^2 - T_{N \max}^2}$$

$T_{K \max}$	= Max. transmissible torque of the coupling [Nm]
$T_{K \max r}$	= Reduced maximum torque of the coupling [Nm]
$T_{N \max}$	= Maximum torque occurring in the application [Nm]

$F_{AN \max}$	= Maximum axial force occurring in the application [kN]
$F_{ax \max}$	= Max. transmissible axial force [kN]
$F_{ax \max r}$	= Reduced axial force [kN]
d	= Shaft diameter [mm]

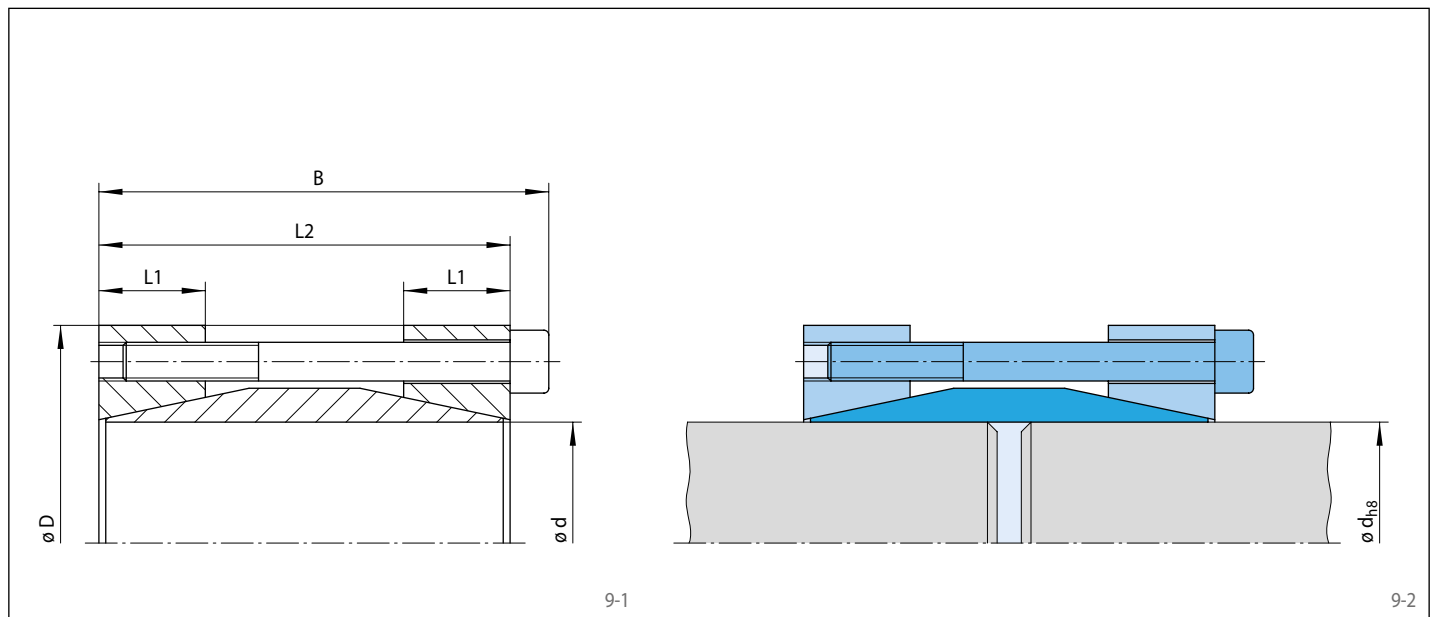

Coupling size d mm	Max. transmissible torque or axial force		Clamping screws				D mm	B mm	L1 mm	L2 mm	Weight kg
	$T_{K \max}$ Nm	$F_{ax \max}$ kN	Tightening torque M_S Nm	Number	Size	Length					
0014	130	18	16	4	M 6	45	45	56	15	50	0,38
0015	140	18	16	4	M 6	45	45	56	15	50	0,35
0016	150	18	16	4	M 6	45	45	56	15	50	0,37
0017	160	18	16	4	M 6	45	45	56	15	50	0,40
0018	160	17	16	4	M 6	45	50	56	15	50	0,45
0019	170	17	16	4	M 6	45	50	56	15	50	0,44
0020	180	18	16	4	M 6	45	50	56	15	50	0,44
0022	310	28	16	6	M 6	55	55	66	18	60	0,50
0024	330	27	16	6	M 6	55	55	66	18	60	0,63
0025	350	28	16	6	M 6	55	55	66	18	60	0,61
0028	340	24	16	6	M 6	55	60	66	18	60	0,75
0030	370	24	16	6	M 6	55	60	66	18	60	0,71
0032	520	32	37	4	M 8	70	75	83	20	75	0,14
0035	570	32	37	4	M 8	70	75	83	20	75	1,33
0038	620	32	37	4	M 8	70	75	83	20	75	1,20
0040	650	32	37	4	M 8	70	75	83	20	75	1,19
0042	990	47	37	6	M 8	80	85	93	22	85	1,80
0045	1050	46	37	6	M 8	80	85	93	22	85	1,72
0050	1200	48	37	6	M 8	80	90	93	22	85	1,80
0055	1700	61	37	8	M 8	80	95	93	22	85	2,00
0060	1950	65	37	8	M 8	80	100	93	22	85	2,17
0065	2150	66	37	8	M 8	80	105	93	22	85	2,60
0070	2800	80	73	6	M 10	80	115	110	35	100	4,10
0075	2900	77	73	6	M 10	80	120	110	35	100	4,30
0080	4200	100	73	8	M 10	80	125	110	35	100	4,48
0090	4700	100	73	8	M 10	80	135	110	35	100	5,20
0100	7600	150	126	8	M 12	100	155	132	40	120	6,00

Bending moments

Where there are bending moments in the application in addition to the torque $T_{N \max}$ or the axial force $F_{AN \max}$, the transmissible torque or transmissible axial force is reduced compared to the values for $T_{K \max}$ or $F_{ax \max}$ as listed in the table. Please contact RINGSPANN.

Mounting

The installation and operating instruction for Cone Clamping Coupling RWK ... EEO is available on request.

Gear Couplings RDZ ... DTO

torsionally rigid
double engagement gearing – lubricated



10-1

Features

- High nominal torques up to 391 500 Nm
- High misalignment capability
- Compensation of axial, radial and angular misalignments
- Double engagement allows smooth torque transmission
- Compact design due to inside turned hubs
- Complies with the AGMA standard (American Gear Manufacturer Association) up to coupling size 0090
- High power density
- Complies with ATEX 2014/34/EU
- Typical applications: Roll drives in the steel and paper industry, pumps, conveyors, fans and blowers

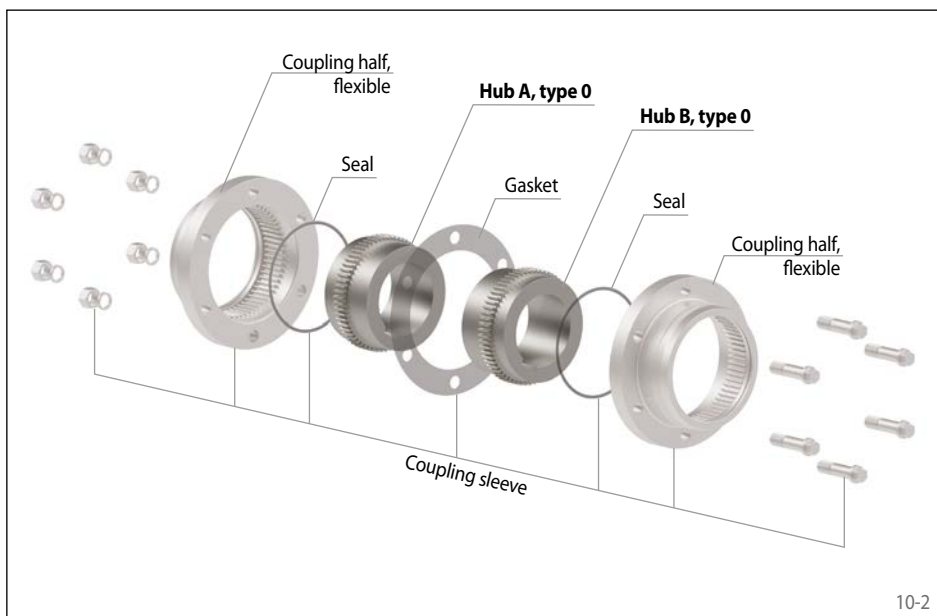

10-2

Order example

	Code
Coupling design	RDZ
Coupling size	0010
Type	DTO
Material of the hub: • Steel	STA
Hub A, type: • 0, standard	0
Hub A, design: • finish bored with keyway • roughbored	FB VA
Bore diameter hub A	020
Hub B, type: • 0, standard	0
Hub B, design: • finish bored with keyway • roughbored	FB VA
Bore diameter hub B	025

RDZ 0010 DTO-STA-0FB020-0FB025

Gear Couplings RDZ ... DTO

torsionally rigid
double engagement gearing – lubricated

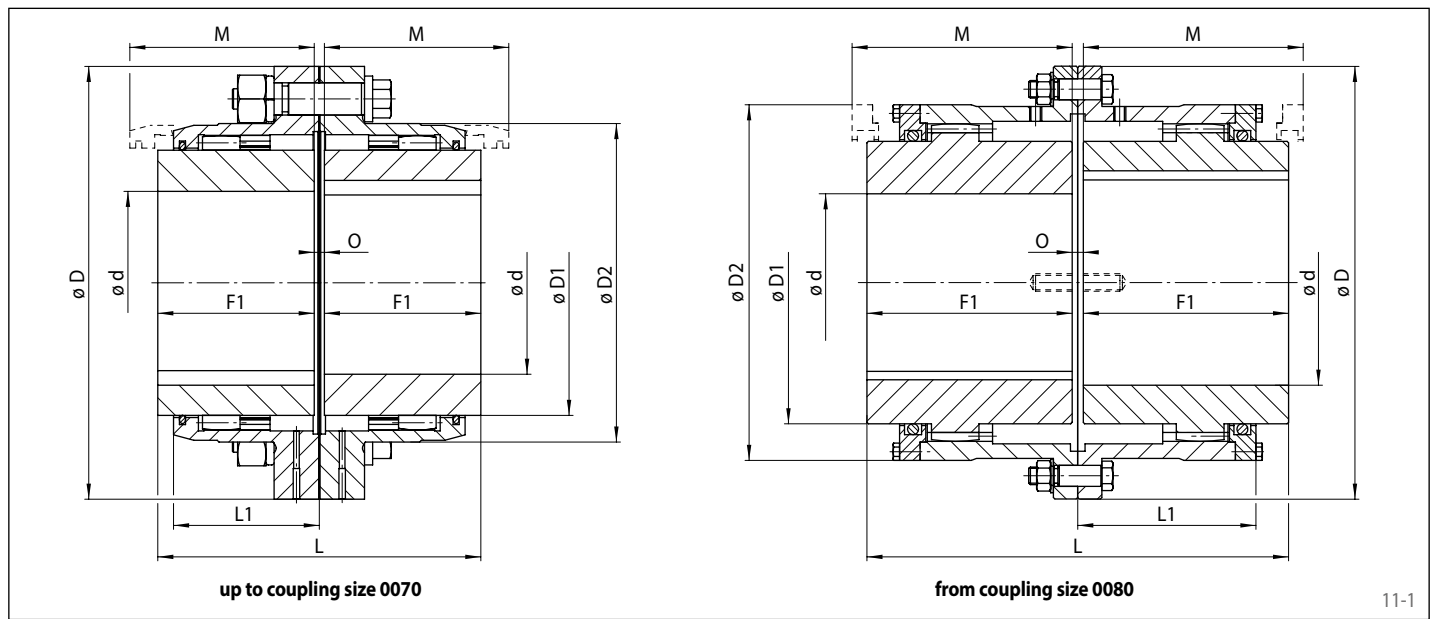

11-1

Coupling size	Nominal torque T_{KN} Nm	Nominal power at 100 min ⁻¹ P_{K100} kW	Max. speed n_{max} min ⁻¹	Moment of inertia with max. bore J_k kgm ²	Permissible misalignments		
					Axial mm	Radial mm	Angular °
0010	1330	14	8000	0,0052	±0,5	0,5	1,5
0015	2860	30	6500	0,0192	±0,5	0,8	
0020	5000	53	5600	0,0410	±0,5	1,0	
0025	10000	105	5000	0,1050	±0,5	1,2	
0030	16000	168	4400	0,1950	±0,5	1,4	
0035	22000	231	3900	0,4540	±1	1,7	
0040	32000	336	3600	0,8600	±1	2,0	
0045	45000	472	3200	1,3900	±1	2,1	
0050	62000	650	2900	2,5300	±1	2,6	
0055	84000	880	2650	3,8300	±1	2,9	
0060	115000	1205	2450	5,2100	±2	3,2	
0070	174000	1823	2150	11,0000	±2	3,7	
0080	252000	2639	1750	20,7200	±2	4,2	
0090	290000	3037	1550	34,9500	±2	4,8	
0100	391500	4100	1450	55,9500	±3	5,5	

Coupling size	Pilot bore d^* mm	Bore d^* mm		D mm	D1 mm	D2 mm	F1 mm	L mm	L1 mm	M** mm	O mm	Weight with max. bore kg
		min. mm	max. mm									
0010	13	15	52	116	69	84	43	89	39	51	3	4,4
0015	19	21	65	152	86	105	50	103	48	61	3	9
0020	26	28	80	178	105	127	62	127	60	76	3	15
0025	30	32	98	213	131	155	77	159	72	92	5	27
0030	36	38	115	240	152	181	91	187	84	106	5	40
0035	36	38	135	279	178	211	107	220	98	130	6	65
0040	36	38	160	318	210	250	121	248	111	145	6	96
0045	50	52	180	346	235	274	135	278	123	165	8	131
0050	69	71	195	389	254	306	153	314	141	183	8	186
0055	68	70	215	425	279	334	168	344	158	203	8	247
0060	105	110	235	457	305	366	188	384	169	228	8	299
0070	105	110	280	527	356	425	221	451	196	266	9	473
0080	105	110	285	590	385	485	249	508	243	300	10	682
0090	145	150	300	660	420	535	276	565	265	325	13	898
0100	155	160	330	711	470	595	305	623	294	355	13	1242

For finish bores, please specify bore diameter hub A and hub B. Tolerance of finish bores H7. Keyways in accordance with DIN 6885, sheet 1. Keyway tolerance JS9, different bore and keyway tolerances on request. Upon request, couplings larger than frame size 0100 also available.
* Bores also available in inch size, see page 73. ** Minimum necessary space to align the shafts.

Gear Couplings RDZ ... DFO

torsionally rigid
single engagement gearing – lubricated

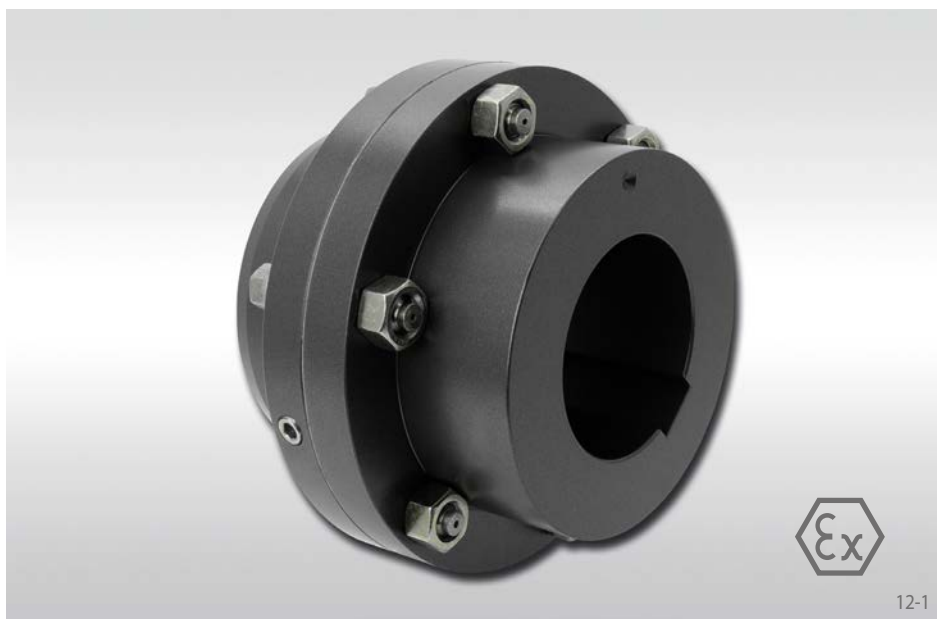

12-1

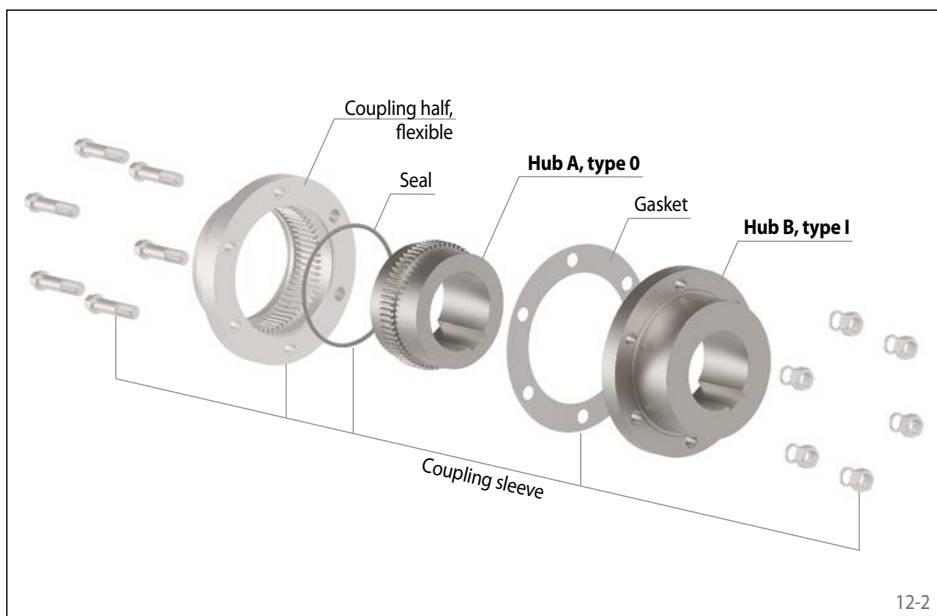

12-2

Features

- High nominal torques up to 391 500 Nm
- Compensation of axial and angular misalignments
- Compact design due to inside turned hubs
- High power density
- Complies with ATEX 2014/34/EU
- Typical applications: Roll drives in the steel and paper industry, pumps, conveyors, fans and blowers

Order example

	Code
Coupling design	RDZ
Coupling size	0010
Type	DFO
Material of the hub: • Steel	STA
Hub A, type: • 0, standard	0
Hub A, design: • finish bored with keyway • roughbored	FB VA
Bore diameter hub A	020
Hub B, type: • I, coupling half, rigid	1
Hub B, design: • finish bored with keyway • roughbored	FB VA
Bore diameter hub B	025

RDZ 0010 DFO-STA-0FB020-1FB025

torsionally rigid
single engagement gearing – lubricated

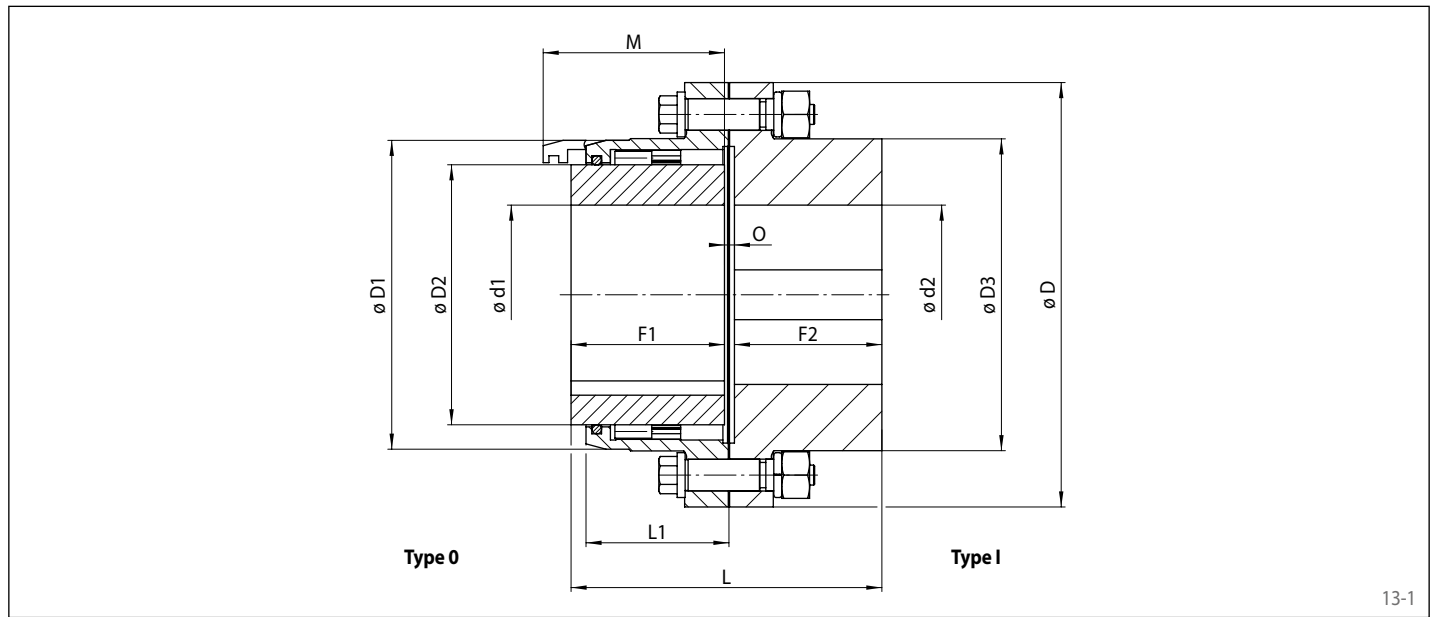

13-1

Coupling size	Nominal torque T_{KN} Nm	Nominal power at 100 min^{-1} P_{K100} kW	Max. speed n_{max} min^{-1}	Moment of inertia with max. bore J_K kgm^2	Permissible misalignments	
					Axial mm	Angular °
0010	1330	14	8000	0,0055	±0,25	0,75
0015	2860	30	6500	0,0204	±0,25	
0020	5000	53	5600	0,0436	±0,25	
0025	10000	105	5000	0,1110	±0,25	
0030	16000	168	4400	0,2100	±0,25	
0035	22000	231	3900	0,4770	±0,5	
0040	32000	336	3600	0,9200	±0,5	
0045	45000	472	3200	1,4680	±0,5	
0050	62000	650	2900	2,7300	±0,5	
0055	84000	880	2650	4,2000	±0,5	
0060	115000	1205	2450	5,7000	±1	
0070	174000	1823	2150	12,0500	±1	
0080	252000	2639	1750	21,7700	±1	
0090	290000	3037	1550	36,6000	±1	
0100	391500	4100	1450	56,2700	±1,5	

Coupling size	Pilot bore d^* mm	Min. bore d^* mm	Max. bore d^* mm		D mm	D1 mm	D2 mm	D3 mm	F1 mm	F2 mm	L mm	L1 mm	M** mm	O mm	Weight with max. bore kg
			Hub type 0 mm	Hub type I mm											
0010	13	15	52	60	116	69	84	84	43	40	87	39	51	4	4,5
0015	19	21	65	80	152	86	105	107	50	47	101	48	61	4	9,5
0020	26	28	80	90	178	105	127	130	62	59	125	60	76	4	15,5
0025	30	32	98	110	213	131	155	157	77	74	156	72	92	5	27,5
0030	36	38	115	130	240	152	181	182	91	88	184	84	106	5	41,5
0035	36	38	135	150	279	178	211	212	107	102	215	98	130	6	67,0
0040	36	38	160	180	318	210	250	250	121	116	245	111	145	8	100,0
0045	50	52	180	200	346	235	274	276	135	131	274	123	165	8	135,0
0050	69	71	195	220	389	254	306	309	153	148	310	141	183	9	195,0
0055	68	70	215	240	425	279	334	334	168	173	350	158	203	9	261,0
0060	105	110	235	260	457	305	366	366	188	185	384	169	228	10	316,0
0070	105	110	280	300	527	356	425	425	221	218	452	196	266	13	500,0
0080	105	110	285	335	590	385	485	470	249	249	511	243	300	13	715,0
0090	145	150	300	370	660	420	535	518	276	276	567	265	325	15	969,0
0100	155	160	330	405	711	470	595	572	305	305	626	294	355	16	1259,0

For finish bores, please specify bore diameter hub A and hub B. Tolerance of finish bores H7. Keyways in accordance with DIN 6885, sheet 1. Keyway tolerance JS9, different bore and keyway tolerances on request.

* Bores also available in inch size, see page 73. ** Minimum necessary space to align the shafts.

Gear Couplings RDZ ... EEO

torsionally rigid
continuous sleeve and double engagement gearing

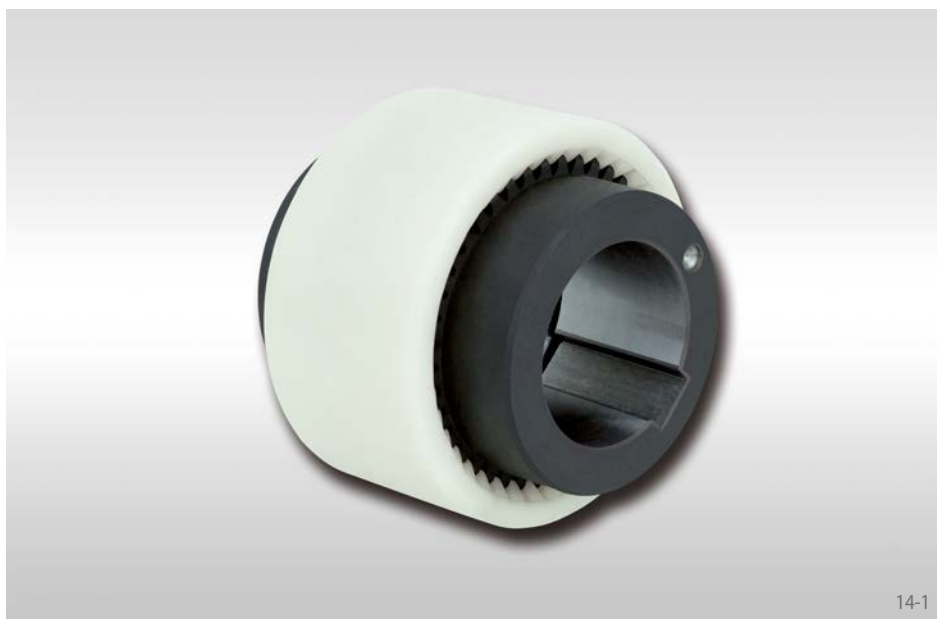

14-1

Features

- Compensation of axial, radial and angular misalignments
- Double engagement allows smooth torque transmission
- Deployable in horizontal and vertical applications
- Temperature range from -25 °C to +100 °C
- Low weight and low moments of inertia
- Maintenance free thanks to a combination of steel and polyamide 6.6
- Typical applications: Hydraulics, pump drives

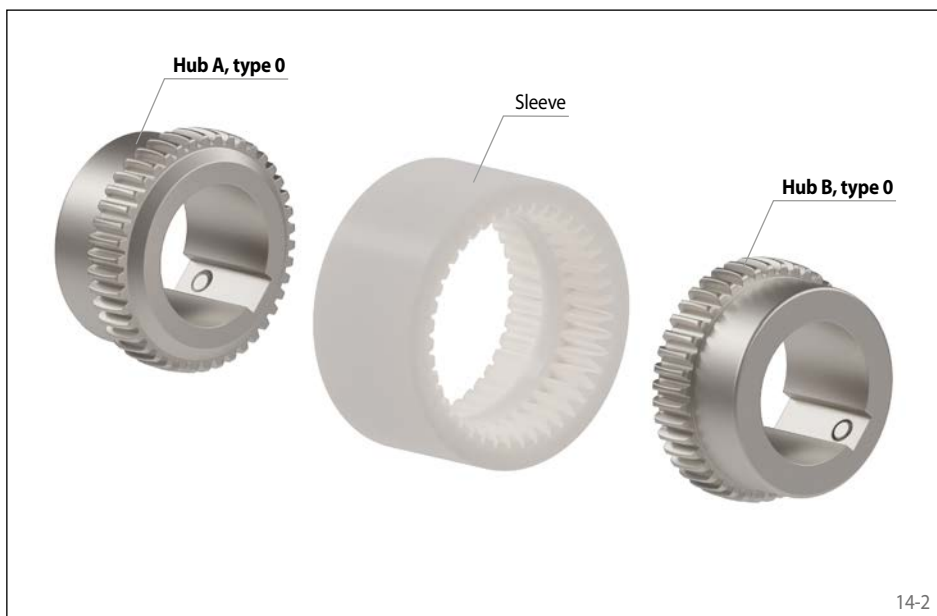

14-2



14-3

Order example

	Code
Coupling design	RDZ
Coupling size	0014
Type	EEO
Material of the hub:	STA
• Steel	
Hub A, type:	0
• 0, standard	
Hub A, design:	FB
• finish bored with keyway	VA
• roughbored	
Bore diameter hub A	015
Hub B, type:	0
• 0, standard	
Hub B, design:	FB
• finish bored with keyway	VA
• roughbored	
Bore diameter hub B	015
Material of the sleeve:	PA66
• Polyamide 6.6	

RDZ 0014 EEO-STA-0FB015-0FB015-PA66

torsionally rigid
continuous sleeve and double engagement gearing

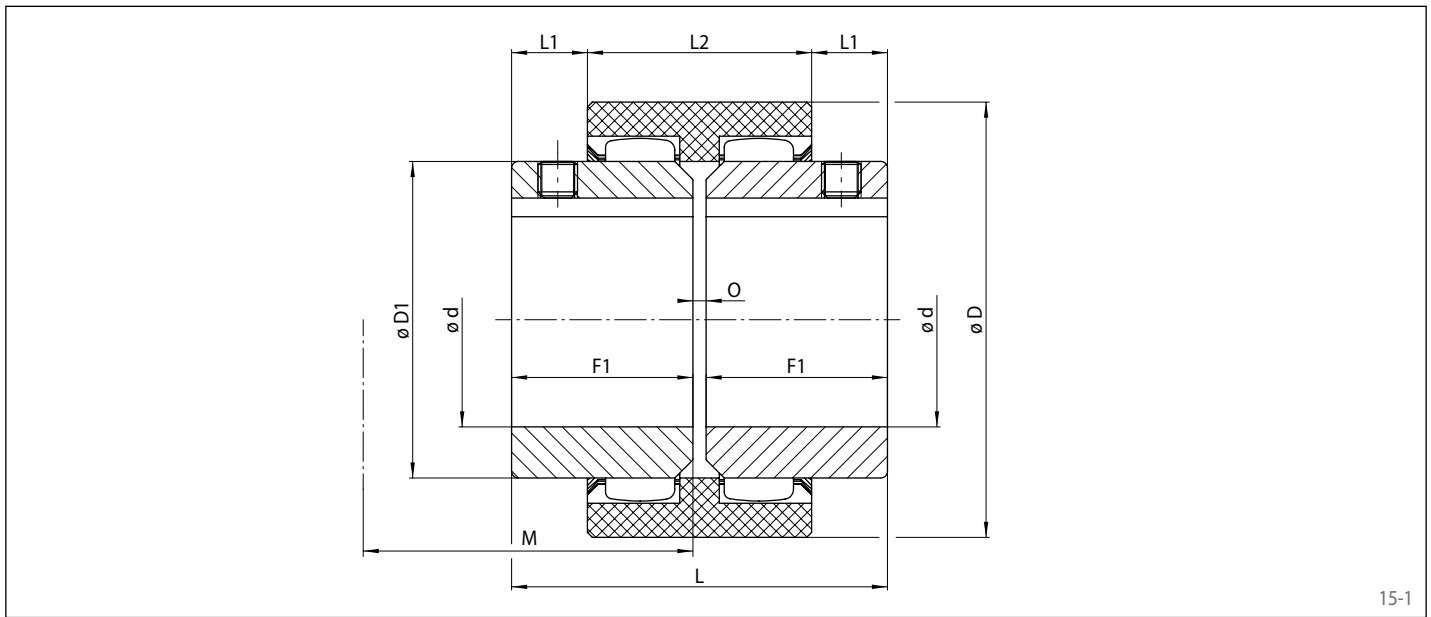

Coupling size	Nominal torque T_{KN} Nm	Nominal power at 100 min^{-1} P_{K100} kW	Max. speed n_{max} min^{-1}	Moment of inertia with max. bore J_k kgcm^2	Permissible misalignments		
					Axial mm	Radial mm	Angular °
0014	10	0,10	14000	0,26	±1	0,3	1
0019	16	0,17	11800	0,47		0,3	
0024	20	0,21	10600	0,93		0,4	
0028	45	0,47	8500	3,09		0,4	
0032	60	0,63	7500	5,48		0,4	
0038	80	0,84	6700	8,68		0,4	
0042	100	1,00	6000	14,28		0,4	
0048	140	1,50	5600	18,34		0,4	
0065	380	4,00	4000	84,80		0,4	

Coupling size	Pilot bore d^* mm	Bore d^* mm		D mm	D1 mm	F1 mm	L mm	L1 mm	L2 mm	M** mm	O mm	Weight with max. bore kg
		min. mm	max. mm									
0014	5	6	15	40	25	23	50	6,5	37	37	4	0,10
0019	10	12	20	48	32	25	54	8,5	37	37	4	0,23
0024	10	12	24	52	36	26	56	7,5	41	41	4	0,32
0028	10	12	28	66	44	40	84	19	46	46	4	0,74
0032	10	12	32	76	50	40	84	18	48	48	4	0,95
0038	10	12	38	83	58	40	84	18	48	48	4	1,23
0042	10	12	42	92	65	42	88	19	50	50	4	1,50
0048	10	12	48	95	68	50	104	27	50	50	4	1,81
0065	10	12	65	132	96	55	114	23	68	68	4	4,35

For finish bores, please specify bore diameter hub A and hub B. Tolerance of finish bores H7. Keyways in accordance with DIN 6885, sheet 1. Keyway tolerance JS9.

* Bores also available in inch size, see page 73.

** Minimum dimensions by which the units need to be pushed apart to enable a radial disassembly of the sleeve.

Selection of IEC standard motors

Frame size	A.C. motor 50 Hz		Motor power n = 3 000 min ⁻¹ 2 pole		RDZ ... EEO Coupling size	Motor power n = 1 500 min ⁻¹ 4 pole		RDZ ... EEO Coupling size	Motor power n = 1 000 min ⁻¹ 6 pole		RDZ ... EEO Coupling size	Motor power n = 750 min ⁻¹ 8 pole		RDZ ... EEO Coupling size
	Shaft end d x l		Power P _{AN}	Torque T _{AN}		Power P _{AN}	Torque T _{AN}		Power P _{AN}	Torque T _{AN}		Power P _{AN}	Torque T _{AN}	
	2 pole	4, 6, 8 pole	kW	Nm		kW	Nm		kW	Nm		kW	Nm	
56	9 x 20		0,09 0,12	0,32 0,41	0014	0,06 0,09	0,43 0,64	0014	0,037 0,045	0,43 0,52	0014	-	-	-
63	11 x 23		0,18 0,25	0,62 0,86		0,12 0,18	0,88 1,3		0,06 0,09	0,7 1,1		-	-	-
71	14 x 30		0,37 0,55	1,3 1,9		0,25 0,37	1,8 2,5		0,18 0,25	2 2,8		0,09 0,12	1,4 1,8	0014
80	19 x 40		0,75 1,1	2,5 3,7	0019	0,55 0,75	3,7 5,1	0,37 0,55	3,9 5,8	0,18 0,25	2,5 3,5	0019		
90S	24 x 50		1,5	5	0024	1,1	7,5	0,75	8	0,37	5,3	0024		
90L			2,2	7,4		1,5	10	1,1	12	0,55	7,9			
100L	28 x 60		3	9,8	0028	2,2 3	15 20	1,5	15	0,75 1,1	11 16	0028		
112M			4	13		4	27	2,2	22	1,5	21			
132S	38 x 80		5,5 7,5	18 25	0038	5,5	36	3	30	2,2	30	0038		
132M			-	-		7,5	49	4 5,5	40 55	3	40			
160M	42 x 110		11 15	36 49	0042	11	72	7,5	75	4 5,5	54 74	0042		
160L			18,5	60		15	98	11	109	7,5	100			
180M	48 x 110		22	71	0048	18,5	121	-	-	-	-	0048		
180L			-	-		22	144	15	148	11	145			
200L	55 x 110		30 37	97 120	0065	30	196	18,5 22	181 215	15	198	0065		
225S	55 x 110	60 x 140	-	-		37	240	-	-	18,5	244			
225M			45	140		45	292	30	293	22	290			
250M	60 x 140	65 x 140	55	177		55	356	37	361	30	392			
280S	65 x 140	75 x 140	75	241		75	484	45	438	37	483			
280M			90	289		90	581	55	535	45	587			
315S	80 x 170	110	353	110		707	-	75	727	-	55		712	-
315M	132	423	132	849		90	873	75	971					
315L	160 200	513 641	160 200	1030 1290	110 132	1070 1280	90 110	90 110						

During selection, the nominal torque of the coupling at +30 °C was factored in with a start-up factor SZ of 1 and a co-efficient of impact SA/SL of 1. Detailed selection in accordance with the technical information on page 70 et seq.

Standard bores

Coupling size	Bore d								
	mm	mm	mm	mm	mm	mm	mm	mm	mm
0014	9	11	14	15	-	-	-	-	-
0019	14	15	18	19	20	-	-	-	-
0024	14	15	18	19	20	22	24	-	-
0028	14	15	18	19	20	22	24	28	-
0032	18	19	20	22	24	28	32	-	-
0038	18	19	20	22	24	28	32	38	-
0042	18	19	20	22	24	28	32	38	42
0048	28	32	38	42	48	-	-	-	-
0065	32	38	42	48	55	60	65	-	-

torsionally rigid
single disc pack

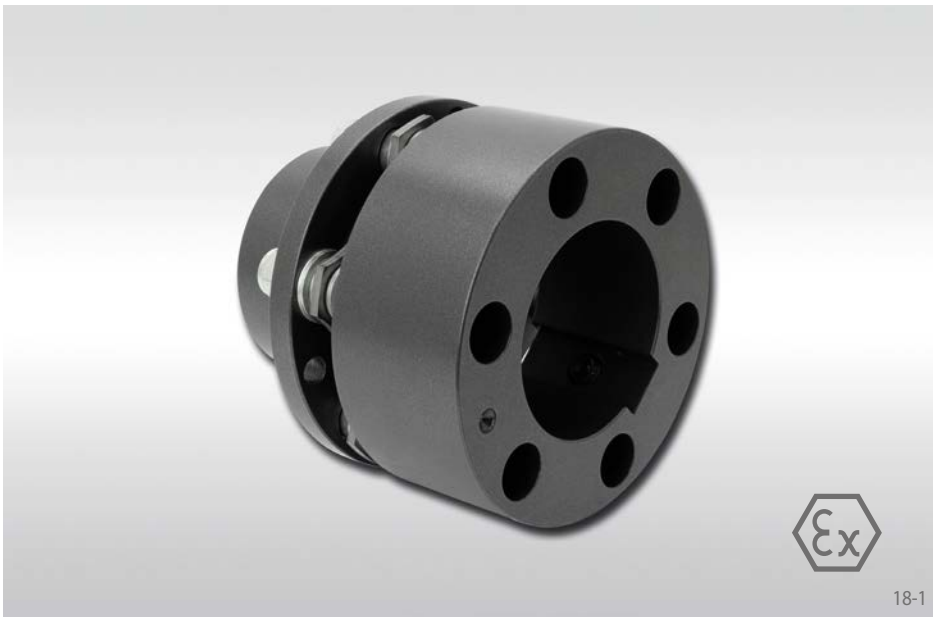

Features

- Nominal torques up to 18 700 Nm
- High torque capacity
- Backlash-free
- Compensation of axial and angular misalignments
- High torsional rigidity with low axial rigidity
- Temperature range -20 °C to +280 °C
- Maintenance free and long life with proper alignment
- Complies with ATEX 2014/34/EU
- Typical applications: Pumps, fans, packaging machines, paper machines, printing machines, conveyor systems, dynamometers, gantry systems

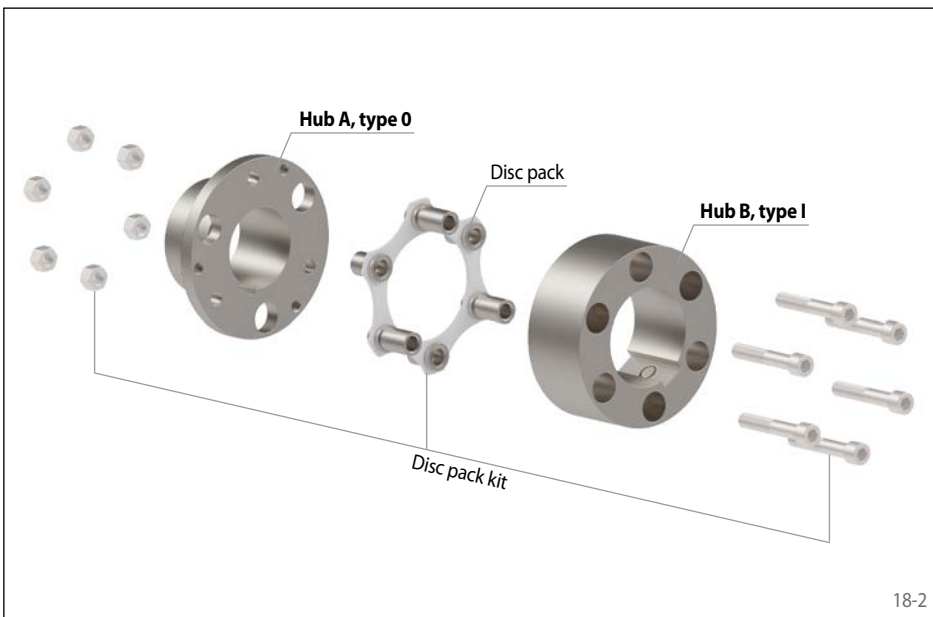

Order example

Order example	Code
Coupling design	RDL
Coupling size	0038
Type	DSO
Material of the hub:	STA
• Steel	
Hub A, type:	
• 0, standard	0
• I, increased max. bore	1
Hub A, design:	
• finish bored with keyway	FB
• roughbored	VA
Bore diameter hub A	025
Hub B, type:	
• 0, standard	0
• I, increased max. bore	1
Hub B, design:	
• finish bored with keyway	FB
• roughbored	VA
Bore diameter hub B	038

RDL 0038 DSO-STA-0FB025-1FB038

torsionally rigid
single disc pack

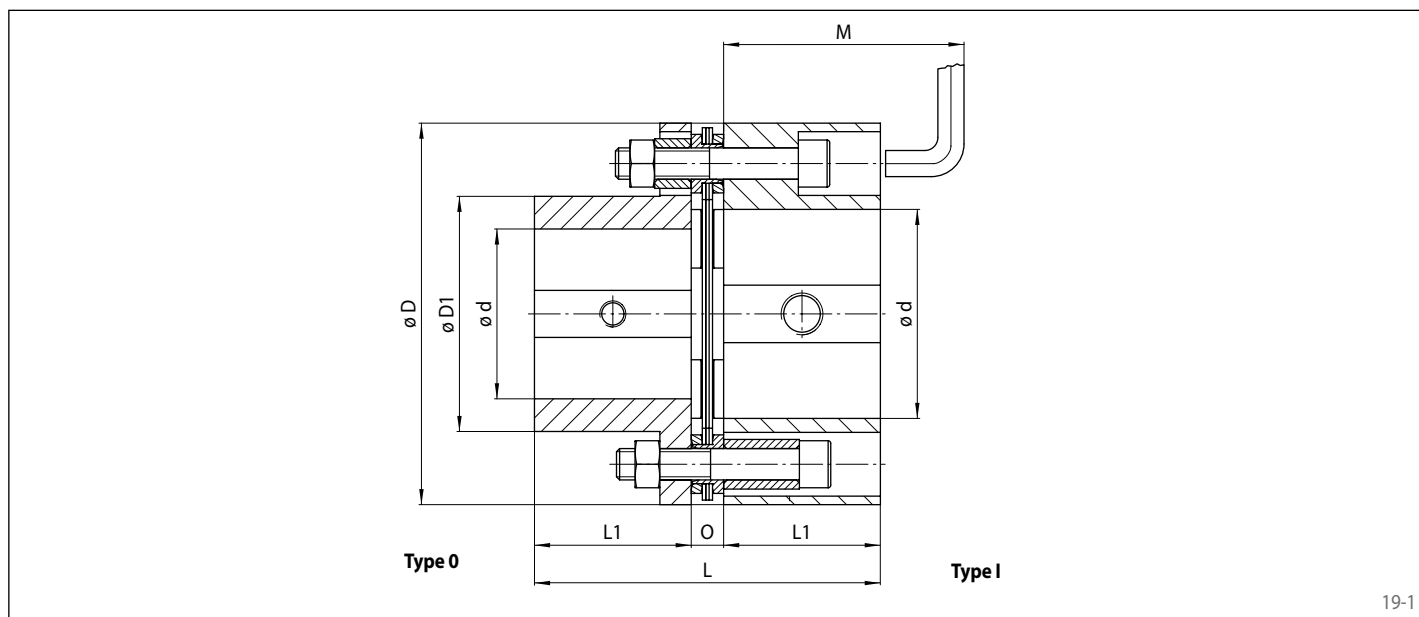

19-1

Coupling size	Nominal torque T_{KN} Nm	Nominal power at 100 min^{-1} P_{K100} kW	Max. speed n_{max} min^{-1}	Torsional stiffness C_T MNm/rad	Moment of inertia J_K kgm^2	Permissible misalignments		
						Axial mm	Radial mm	Angular °
0024	96	1,0	7500	0,041	0,00047	±1	Due to design, no radial misalignments are permissible.	0,75
0038	232	2,4	7000	0,093	0,00170			
0048	620	6,5	6000	0,248	0,00820			
0065	1200	12,6	5200	0,529	0,01430			
0075	1910	20,0	4800	0,895	0,02630			
0100	3460	36,3	4400	1,665	0,06400			
0110	5600	58,5	4200	2,393	0,13200			
0125	7100	74,2	4000	3,490	0,32110			
0140	10400	108,7	3800	on demand	0,39450			
0150	14500	152,2	3700		0,63500			
0160	18700	196,0	3600		1,00500	±2		

Torsional stiffness and moment of inertia refer to a combination of hub type 0 and hub type I with max. possible bore diameter respectively.

Coupling size	Pilot bore d^* mm	Min. bore d^*		Max. bore d^*		D mm	D1 mm	L mm	L1 mm	M** mm	Gap O mm	Weight kg
		Hub type 0 mm	Hub type I mm	Hub type 0 mm	Hub type I mm							
0024	8	10	23	22	25	63	35	66,5	30	75	6,5	0,9
0038	10	12	31	30	38	82	45	86,5	40	85	6,5	1,8
0048	15	17	41	40	50	102	57	98,0	45	95	8,0	3,2
0065	15	17	53	52	70	128	77	119,5	55	110	9,5	5,8
0075	20	22	66	65	80	146	94	132,0	60	120	12,0	8,5
0100	25	27	81	80	100	176	115	153,0	70	140	13,0	14,0
0110	30	32	91	90	115	197	132	194,5	90	175	14,4	22,2
0125	40	42	106	105	130	225	147	206,1	95	185	16,2	30,5
0140	45	47	116	115	140	250	162	229,4	105	195	19,5	42,7
0150	50	52	121	120	155	275	178	251,5	115	215	21,5	57,3
0160	60	62	136	135	165	300	190	283,6	130	235	23,5	76,1

For finish bores, please specify bore diameter hub A and hub B. Tolerance of finish bores H7. Keyways in accordance with DIN 6885, sheet 1. Keyway tolerance JS9, different bore and keyway tolerances on request.

The weight refers to a combination of hub type 0 and hub type I with max. possible bore diameter respectively.

In deviation from figure 19-1, the combination of the hub type 0 / 0 is possible.

Upon request, also available with taper bushes.

Upon request, couplings larger than frame size 0160 also available.

For vertical installation, please contact RINGSPANN.

* Bores also available in inch size, see page 73.

** Distance M is required to tighten and loosen the screws for hub type I.

Disc Couplings RDL ... DSZ

torsionally rigid
double disc packs with spacer



Features

- Nominal torques up to 18 700 Nm
- High torque capacity
- Backlash-free
- Compensation of axial, radial and angular misalignments
- Double disc pack allows smooth torque transmission
- High torsional rigidity with low axial rigidity
- Temperature range -20 °C to +280 °C
- Maintenance free and long life with proper alignment
- Complies with ATEX 2014/34/EU
- Typical applications: Pumps, fans, packaging machines, paper machines, printing machines, mixers, dynamometers

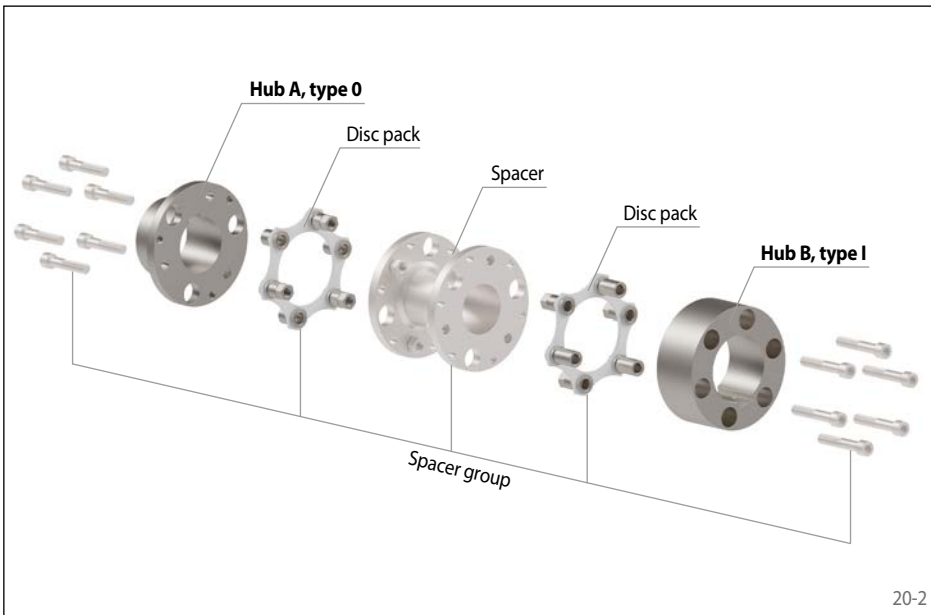

Order example

	Code
Coupling design	RDL
Coupling size	0024
Type	DSZ
Material of the hub: • Steel	STA
Hub A, type: • 0, standard • I, increased max. bore	0 1
Hub A, design: • finish bored with keyway • roughbored	FB VA
Bore diameter hub A	020
Hub B, type: • 0, standard • I, increased max. bore	0 1
Hub B, design: • finish bored with keyway • roughbored	FB VA
Bore diameter hub B	025
DBSE L3	0100

RDL 0024 DSZ-STA-0FB020-1FB025-0100

torsionally rigid
double disc packs with spacer

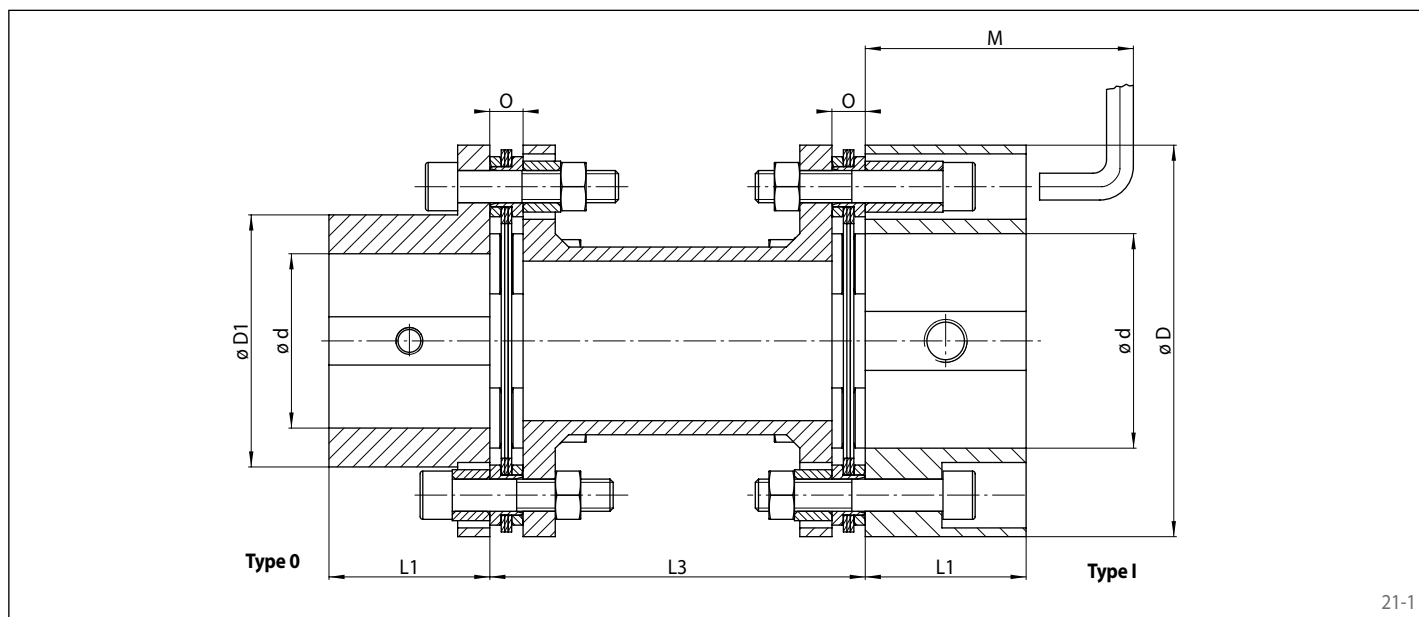

21-1

Coupling size	Nominal torque T_{KN} Nm	Nominal power at 100 min^{-1} P_{K100} kW	Max. speed n_{max} min^{-1}	Torsional stiffness C_T MNm/rad	Moment of inertia J_K with DBSE L3		Permissible misalignments		
					with shortest standard kgm ²	per additional meter to the standard kgm ²	Axial mm	Radial mm	Angular °
0024	96	1,0	7500	0,021	0,0006	0,0004	±2	L3 x 0,013	1,5
0038	232	2,4	7000	0,047	0,0021	0,0011			
0048	620	6,5	6000	0,100	0,0062	0,0017			
0065	1200	12,6	5200	0,222	0,0180	0,0047			
0075	1910	20,0	4800	0,381	0,0350	0,0088			
0100	3460	36,3	4400	0,773	0,0850	0,0210			
0110	5600	58,5	4200	0,962	0,1678	0,0560			
0125	7100	74,2	4000	1,529	0,3098	0,0560			
0140	10400	108,7	3800	1,892	0,5328	0,0670			
0150	14500	152,2	3700	2,454	0,8610	0,1670			
0160	18700	196,0	3600	3,783	1,3580	0,1670	±4		

Torsional stiffness and moment of inertia refer to a combination of hub type 0 and hub type I with max. possible bore diameter respectively and shortest standard DBSE L3.

Coupling size	Pilot bore d^* mm	Min. bore d^* mm		Max. bore d^* mm		D mm	D1 mm	L1 mm	DBSE L3		M** mm	Gap O mm	Weight with DBSE L3	
		Hub type 0 mm	Hub type I mm	Hub type 0 mm	Hub type I mm				shortest possible mm	Standard mm			with shortest standard kg	per additional meter to the standard kg
0024	8	10	23	22	25	63	35	30	54	100 140 180	75	6,5	1,3	2,3
0038	10	12	31	30	38	82	45	40	54	100 140 180	85	6,5	2,3	3,2
0048	15	17	41	40	50	102	57	45	66		95	8,0	4,7	3,2
0065	15	17	53	52	70	128	77	55	78	180 250	110	9,5	8,0	7,0
0075	20	22	66	65	80	146	94	60	88	140 180 250	120	12,0	11,4	8,4
0100	25	27	81	80	100	176	115	70	102		140	140	13,0	19,5
0110	30	32	91	90	115	197	132	90	114	180 250	175	14,4	29,3	21,7
0125	40	42	106	105	130	225	147	95	132	180 250	185	16,2	42,1	21,7
0140	45	47	116	115	140	250	162	105	144		195	19,5	61,0	27,1
0150	50	52	121	120	155	275	178	115	168	180 250	215	21,5	81,7	42,8
0160	60	62	136	135	165	300	190	130	170	235	23,5	106,9	42,8	

For finish bores, please specify bore diameter hub A and hub B. Tolerance of finish bores H7. Keyways in accordance with DIN 6885, sheet 1. Keyway tolerance JS9, different bore and keyway tolerances on request. • The weight refers to the shortest standard DBSE L3.

Upon request: Varying DBSEs L3; Designs with taper bushes; Couplings larger than frame size 0160

In deviation from figure 21-1, a combination of the hubs of type 0 / 0 and type I / I is possible.

For vertical installation, please contact RINGSPANN.

* Bores also available in inch size, see page 73. • ** Distance M is required to tighten and loosen the screws for hub type I.

torsionally rigid
double disc packs, design according to API 610



Features

- Nominal torques up to 18 700 Nm
- High torque capacity
- Backlash-free
- Compensation of axial, radial and angular misalignments
- Double disc pack allows smooth torque transmission
- High torsional rigidity with low axial rigidity
- Temperature range -20 °C to +280 °C
- Complies with ATEX 2014/34/EU
- Typical applications: Centrifugal pumps, screw pumps, turbo compressors, rotary piston fans

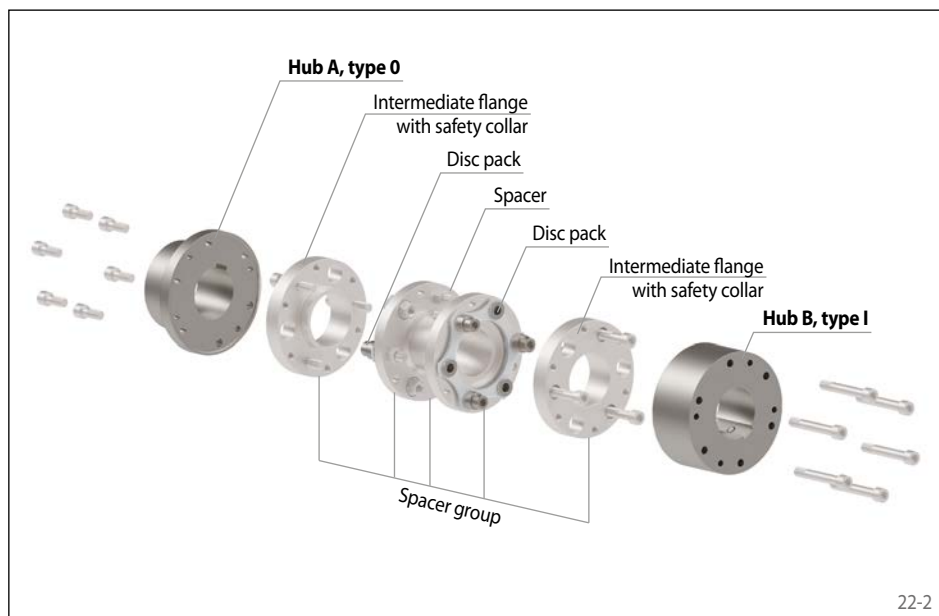

Additional features

- No wear with optimal alignment, no lubrication necessary
- Corresponds to the provisions in accordance with API 610 and optionally, upon request, with the requirements in accordance with API 671

Order example

	Code
Coupling design	RDL
Coupling size	0048
Type	DSA
Material of the hub:	STA
• Steel	
Hub A, type:	
• 0, standard	0
• I, increased max. bore; pitch diameter Ta	1
• II, extended	2
• III, extended, increased max. bore; pitch diameter Tb	3
Hub A, design:	
• finish bored with keyway	FB
• roughbored	VA
Bore diameter hub A	045
Hub B, type:	
• 0, standard	0
• I, increased max. bore; pitch diameter Ta	1
• II, extended	2
• III, extended, increased max. bore; pitch diameter Tb	3
Hub B, design:	
• finish bored with keyway	FB
• roughbored	VA
Bore diameter hub B	060
DBSE L3	0180

RDL 0048 DSA-STA-0FB045-1FB060-0180

torsionally rigid
double disc packs, design according to API 610

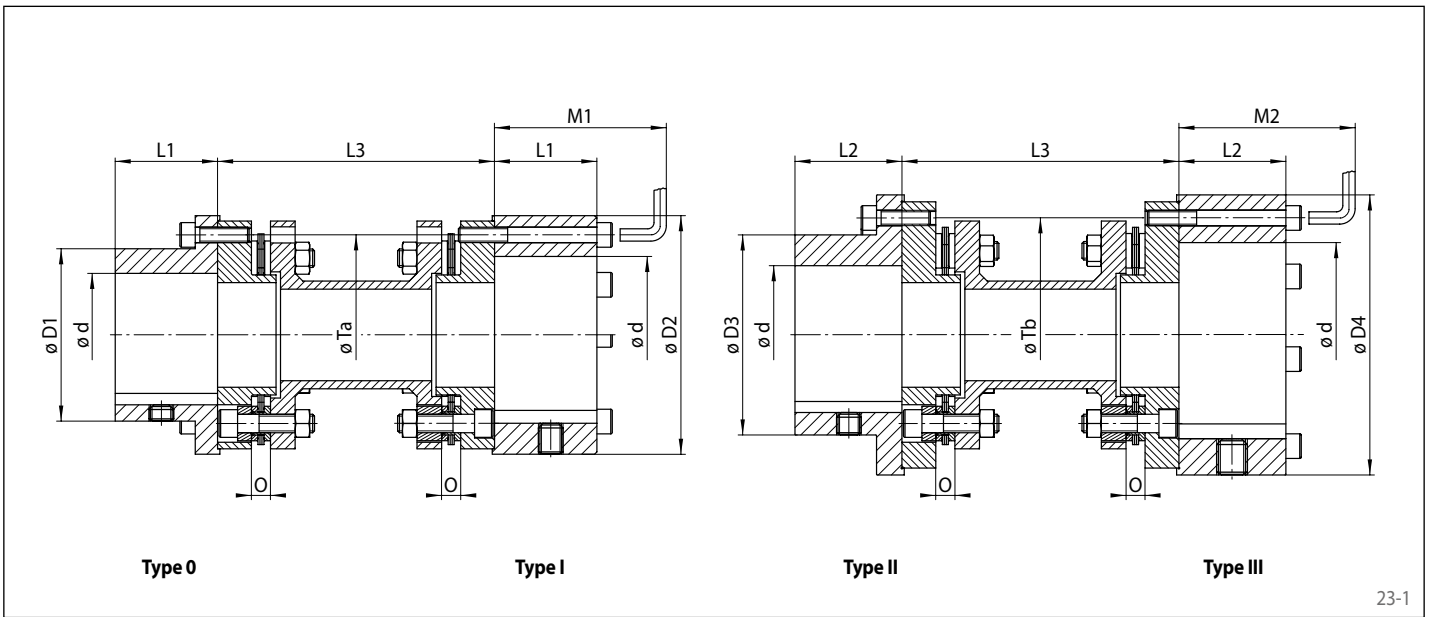

23-1

Coupling size	Nominal torque T_{KN} Nm	Nominal power at 100 min^{-1} P_{K100} kW	Max. speed n_{max} min^{-1}	Torsional stiffness C_T MNm/rad	Moment of inertia J_K with DBSE L3		Permissible misalignments		
					with shortest standard kgm ²	per additional meter to the standard kgm ²	Axial mm	Radial mm	Angular °
0024	96	1,0	7500	0,018	0,0012	0,0002	±2	L3 x 0,013	1,5
0038	232	2,4	7000	0,043	0,0039	0,0006			
0048	620	6,5	6000	0,100	0,0094	0,0011			
0065	1200	12,6	5200	0,232	0,0283	0,0034			
0075	1910	20,0	4800	0,395	0,0604	0,0088			
0100	3460	36,3	4400	0,749	0,1410	0,0213			
0110	5600	58,5	4200	1,239	0,3650	0,0561			
0125	7100	74,2	4000	1,649	0,4181	0,0561			
0140	10400	108,7	3800	2,179	0,7067	0,0670			
0150	14500	152,2	3700	3,350	1,1340	0,1666			
0160	18700	196,0	3600	4,271	1,7740	0,1666	±4		

Torsional stiffness and moment of inertia refer to a combination of hub type 0 and hub type I with max. possible bore diameter respectively and shortest standard DBSE L3.
* Higher speeds on request.

Coupling size	Pilot bore d^* mm	Min. bore d^*		Max. bore d^*				D1	D2	D3	D4	L1	L2	DBSE L3		M1**	M2**	Gap O	Weight with DBSE L3	
		Hub type 0 / I mm	Hub type II / III mm	Hub type 0 mm	Hub type I mm	Hub type II mm	Hub type III mm							shortest possible mm	Standard mm				with shortest standard kg	per additional meter to the standard kg
0024	6	8	10	24	42	38	48	40	69	55	90	30	40	80	100 140 180 250	80	90	7,5	2	1,32
0038	8	10	15	38	48	48	72	55	90	70	108	40	45	89	140 180 250	90	105	7,5	4	2,29
0048	13	15	20	48	72	65	92	70	108	86	135	45	55	103	140 180 250	105	120	8,5	9	3,19
0065	18	20	25	65	92	80	102	86	135	108	152	55	60	128	140 180 250	120	125	9,2	16	4,47
0075	23	25	30	80	102	90	120	108	152	130	182	60	70	148	140 180 250	125	135	12,4	22	8,38
0100	28	30	45	90	120	108	140	130	182	158	197	70	90	161	180 250	135	155	10,6	33	13,08
0110	43	45	55	108	140	127	155	158	197	181	225	90	95	175	180 250	155	160	13,9	49	21,72
0125	53	55	65	127	155	140	178	181	225	206	250	95	105	180	180 250	160	170	14,5	61	21,72
0140	63	65	70	140	178	155	192	206	250	223	275	105	115	194	180 250	170	190	15,9	83	27,06
0150	68	70	75	155	192	170	212	223	275	248	300	115	130	213	250	190	215	17,4	105	42,79
0160	73	75	80	170	212	190	255	248	300	280	375	130	145	225	250	215	245	18,3	136	42,79

For finish bores, please specify bore diameter hub A and hub B. Tolerance of finish bores H7. Keyways in accordance with DIN 6885, sheet 1. Keyway tolerance JS9, different bore and keyway tolerances on request.

The weight refers to a combination of hub type 0 and hub type I with max. possible bore diameter respectively and shortest standard DBSE L3.

When ordering please specify hub type. Possible hub combinations: Type 0 / 0 / I / I / I / II / II / III / III / III / III; Pitch diameter T_a and T_b are not identical.

Upon request: Varying DBSEs L3; Design in accordance with ATEX 2014/34/EU; Designs with taper bushes; Couplings larger than frame size 0160

For vertical installation, please contact RINGSPANN.

* Bores also available in inch size, see page 73. • ** Distance M1 and M2 is required to tighten and loosen the screws for hub type I and type III.

Design RDA ... ESO-...-0...

Hub with keyway

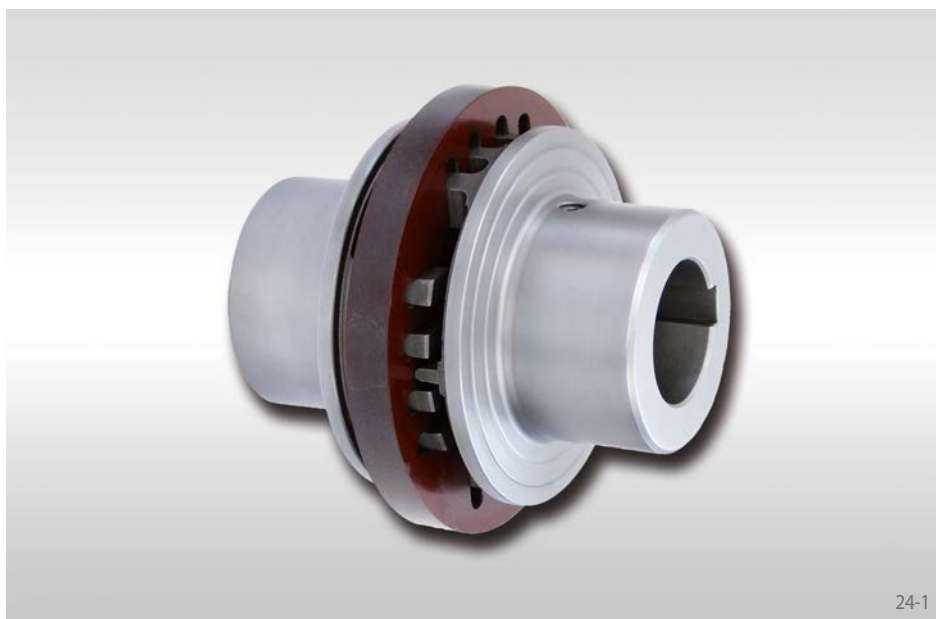

24-1

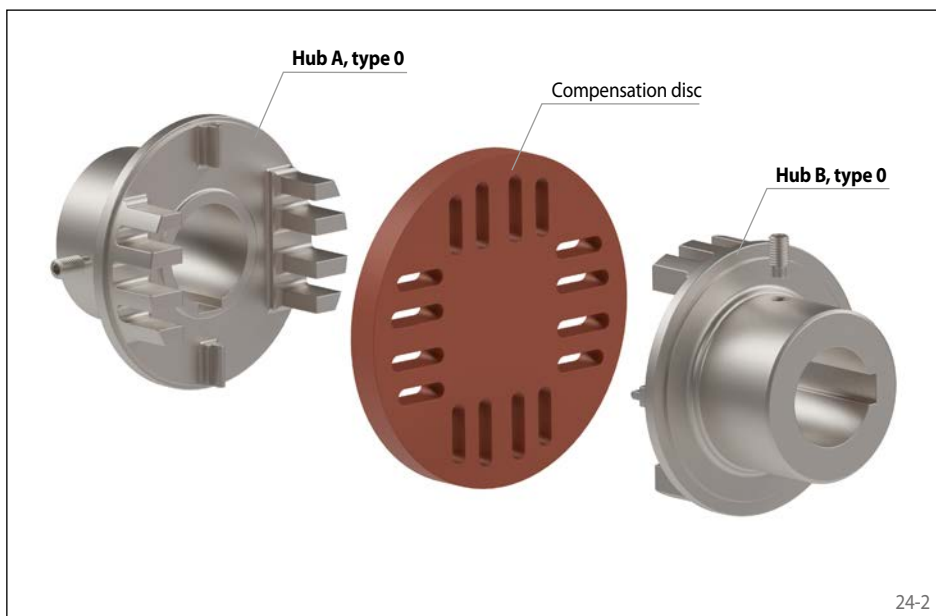

24-2

Features

- Compact design
- Simple robust design
- Electrical insulation
- No stick-slip effect
- Large radial shaft misalignment permissible
- Torsionally rigid
- Minimal restoring forces to adjacent machine parts
- Typical applications: Printing machines, machine tools

Order example

	Code
Coupling design	RDA
Coupling size	0012
Type	ESO
Material of the hub:	
• Steel	STA
• Nodular cast iron	GJS
Hub A, type:	
• 0, standard	0
Hub A, design:	
• finish bored with keyway	FB
• roughbored	VA
Bore diameter hub A	010
Hub B, type:	
• 0, standard	0
Hub B, design:	
• finish bored with keyway	FB
• roughbored	VA
Bore diameter hub B	015
Material of the compensation disc:	
• HGW 2082 in accordance with DIN 7735	HG82
• PARA-GF60*	PAGF

RDA 0012 ESO-GJS-0FB010-0FB015-HG82

*RDA 0010 ESO only

Design RDA ... ESO-...-0...

Hub with keyway

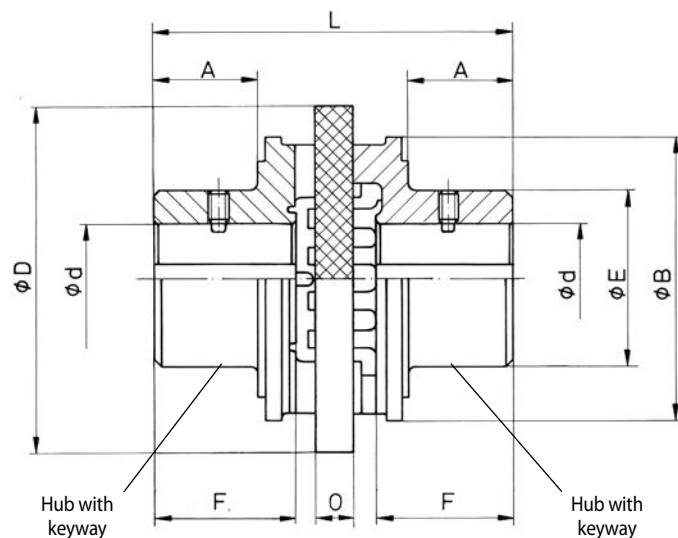

25-1

Coupling size	Material of the hub		Max. torque T_{Kmax} Nm	Max. speed n_{max} min ⁻¹	Moment of inertia J_k kgm ²	Max. misalignments**		Pilot bore d mm	Finish bore d		A mm	B mm	D mm	E mm	F*** mm	L mm	O mm	Weight with rough bore kg
	Steel STA	Nodular cast iron GJS				Axial +/- mm	Radial mm		min. mm	max. mm								
0010*	x	-	2	13000	0,0001	0,75	0,50	4,3	5	15	-	-	32	26	13	35	6	0,10
0012	x	-	4	10500	0,0002	0,75	0,60	5	6	18	-	-	40	32	16	42	4	0,20
0016	x	-	8	8400	0,0003	0,75	0,80	7	8	25	-	-	50	40	18,5	51	6	0,38
0020	x	-	16	6800	0,0004	1,00	1,00	9	10	30	-	-	63	50	25	64	6	0,78
0027	x	-	32	5350	0,0008	1,25	1,35	11	12	40	-	-	80	65	32	85	8	1,70
0035	-	x	85	4100	0,0013	1,50	1,75	15	16	35	33	90	110	53	42	112	12	1,90
0042	-	x	190	3400	0,0039	1,50	2,10	19	20	42	41	110	135	66	53	136	14	3,70
0050	-	x	500	2670	0,0097	2,00	2,50	29	30	50	51	135	160	85	62	159	16	6,30
0070	-	x	1000	2140	0,0268	2,00	3,50	33	34	70	65	163	200	104	79	200	20	12,10
0090	-	x	2000	1700	0,1110	2,50	4,50	48	50	90	81	202	250	150	100	247	25	28,90
0110	-	x	4000	1350	0,2911	4,00	5,50	58	60	110	101	254	315	175	124	312	32	50,90
0140	-	x	8000	1050	0,9767	4,50	7,00	72	75	140	130	330	400	216	160	402	40	104,00

For finish bores, please specify bore diameter hub A and hub B. Tolerance of finish bores H7. Keyways in accordance with DIN 6885, sheet 1. Keyway tolerance P9.

* Material of compensation disc PARA-GF60

** Max. angular displacement 3°.

*** The hub length F can be shortened, which would change the dimensions A, C and L accordingly.

Elastomer element	Material	Temperature range °C	Colour
HGW 2082	Cotton fabric-phenolic	up to +100	red

Flexible Couplings RDA ... ESO

Design RDA ... ESO-STA-1KA ...

Hub with backlash-free clamping connection



Features

- Compact design
- Simple robust design
- Electrical insulation
- No stick-slip effect
- Large radial shaft misalignment permissible
- Torsionally rigid
- Minimal restoring forces to adjacent machine parts
- Typical applications: Printing machines, machine tools

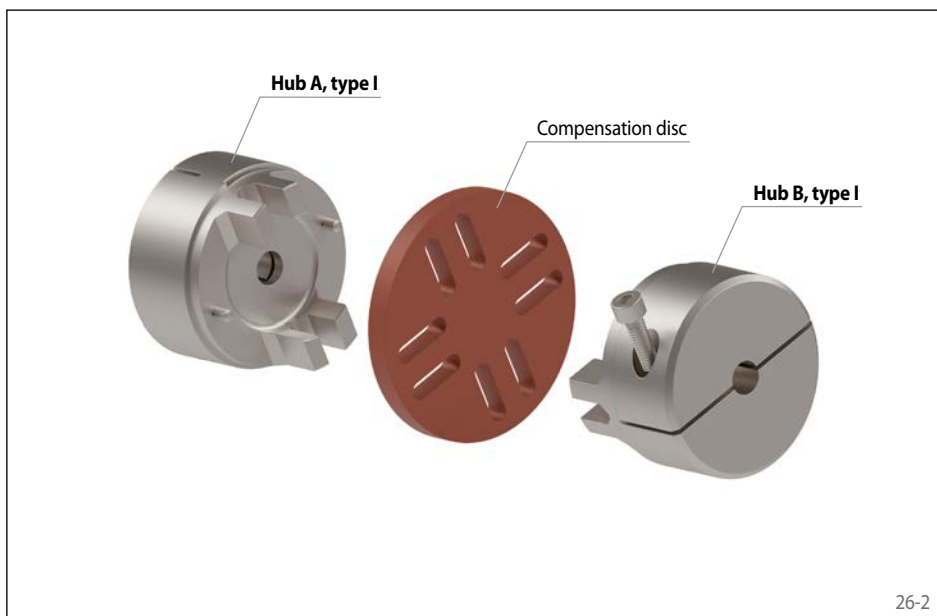

Order example

Order example	Code
Coupling design	RDA
Coupling size	0012
Type	ESO
Material of the hub:	STA
• Steel	
Hub A, type:	1
• I, clamping hub	
Hub A, design:	KA
• Clamping hub, single slotted, metric bore, H7, without keyway	
Bore diameter hub A	005
Hub B, type:	1
• I, clamping hub	
Hub B, design:	KA
• Clamping hub, single slotted, metric bore, H7, without keyway	
Bore diameter hub B	010
Material of the compensation disc:	HG82
• HGW 2082 in accordance with DIN 7735	PAGF
• PARA-GF60*	

RDA 0012 ESO-STA-1KA005-1KA010-HG82

*RDA 0010 ESO only

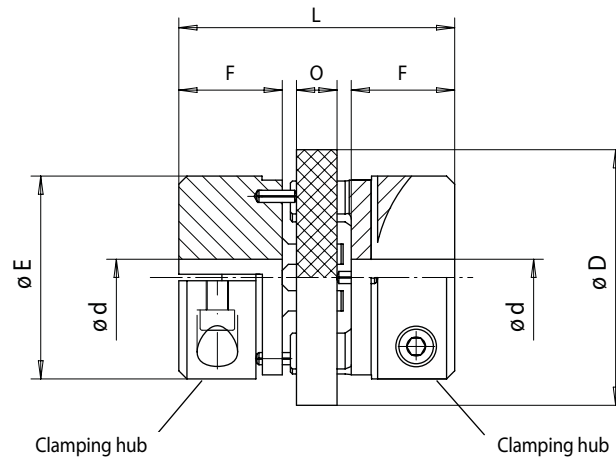

27-1

Coupling size	Max. torque T_{Kmax} Nm	Max. speed n_{max} min^{-1}	Moment of inertia J_K kgm^2	Max. misalignments**		Finish bore d		D mm	E mm	F mm	L mm	O mm	Weight with rough bore kg
				Axial +/- mm	Radial mm	min. mm	max. mm						
0010*	2	13000	0,0001	0,75	0,5	5	10	32	26	13	35	6	0,10
0012	4	10500	0,0002	0,75	0,6	6	14	40	32	16	42	4	0,20
0016	8	8400	0,0003	0,75	0,8	8	20	50	40	18,5	51	6	0,38
0020	16	6800	0,0004	1,00	1,0	10	25	63	50	25	64	6	0,78
0027	32	5350	0,0008	1,25	1,35	12	35	80	65	32	85	8	1,70

For finish bores, please specify bore diameter hub A and hub B. Tolerance of finish bores H7. Keyway tolerance P9.

* Material of compensation disc PARA-GF60

** Max. angular displacement 3°.

Elastomer element	Material	Temperature range °C	Colour
HGW 2082	Cotton fabric-phenolic	up to +100	red

Flexible Couplings RDA ... ESO

Design RDA ... ESO-GJS-2PE ...

Hub with mounting flange with through bores



28-1

Features

- Compact design
- Simple robust design
- Electrical insulation
- No stick-slip effect
- Large radial shaft misalignment permissible
- Torsionally rigid
- Minimal restoring forces to adjacent machine parts
- Typical applications: Printing machines, machine tools

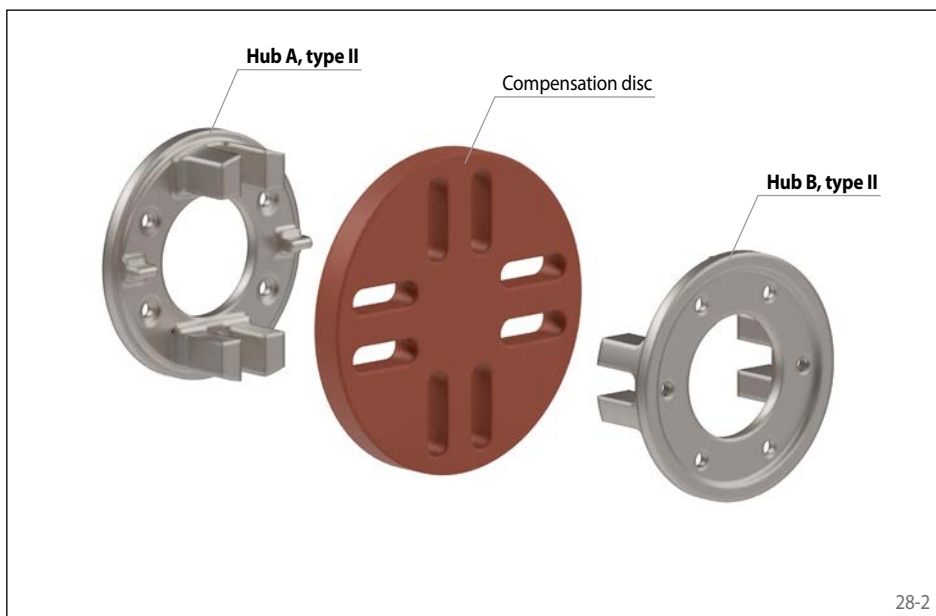

28-2

Order example

	Code
Coupling design	RDA
Coupling size	0110
Type	ESO
Material of the hub: • Nodular cast iron	GJS
Hub A, type: • II, flange hub	2
Hub A, design: • Mounting flange with through bore, arrangement of the fastening holes according to hole pattern	PE
Pitch diameter T hub A	180
Hub B, type: • II, flange hub	2
Hub B, design: • Mounting flange with through bore, arrangement of the fastening holes according to hole pattern	PE
Pitch diameter T hub B	180
Material of the compensation disc: • HGW 2082 in accordance with DIN 7735	HG82

RDA 0110 ESO-GJS-2PE180-2PE180-HG82

Design RDA ... ESO-GJS-2PE ...

Hub with mounting flange with through bores

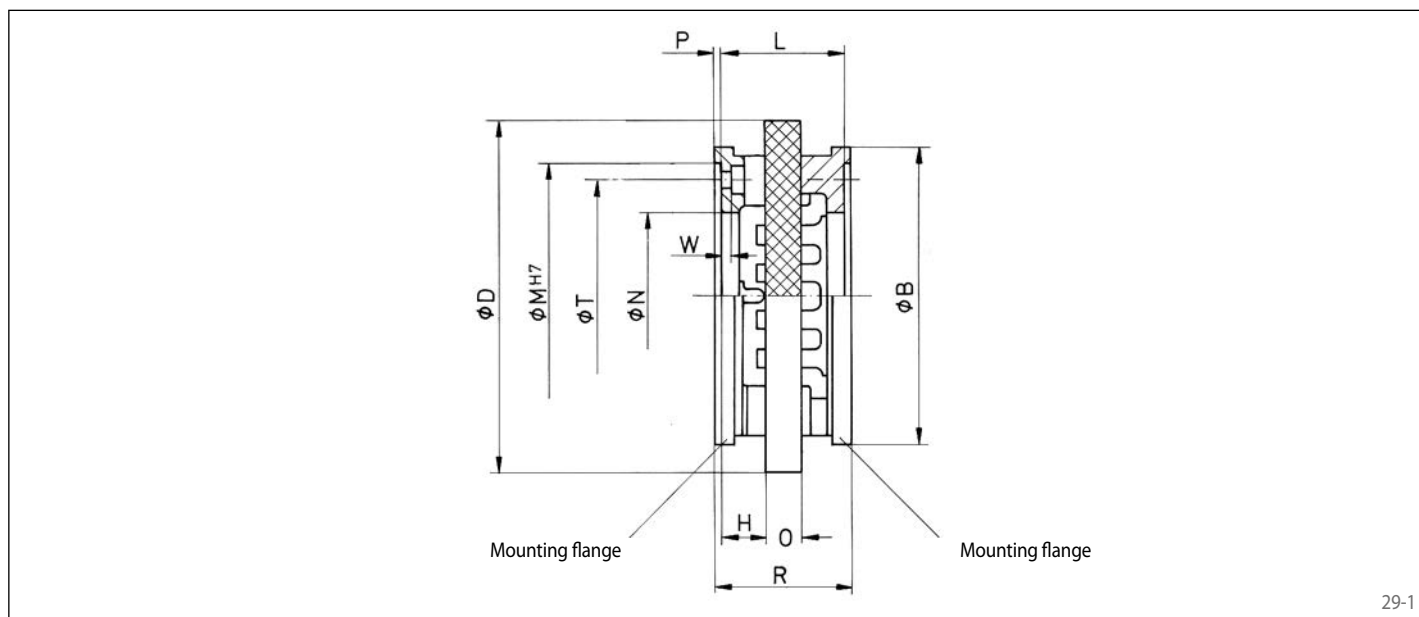

Coupling size	Max. torque T_{Kmax} Nm	Max. speed n_{max} min^{-1}	Moment of inertia J_K kgm^2	Max. misalignments*		B mm	D mm	H mm	L mm	M ^{H7} mm	N mm	O mm	P mm	R mm	T mm	W mm	Z	Hole pattern**	Weight with rough bore kg
				Axial +/- mm	Radial mm														
0035	85	4100	0,0009	1,50	1,75	90	110	14,5	41	75	45	12	2,5	46	65	3,5	M 6	1	0,7
0042	190	3400	0,0026	1,50	2,1	110	135	15,5	45	90	52	14	2,5	50	75	4,5	M 6	2	1,4
0050	500	2670	0,0053	2,00	2,5	135	160	18,0	52	100	65	16	4,5	61	88	4,5	M 8	2	1,9
0051	500	2670	0,0051	2,00	2,5	135	160	17,5	51	125	76	16	3,0	57	108	5,0	M 8	3	1,7
0070	1000	2140	0,0138	2,00	3,5	163	200	21,0	62	135	90	20	4,0	70	115	5,5	M 10	2	3,2
0090	2000	1700	0,0453	2,50	4,5	202	250	26,5	78	170	104	25	4,5	87	150	7,0	M 10	4	7,0
0110	4000	1350	0,1314	4,00	5,5	254	315	32,0	96	200	146	32	5,0	106	180	5,0	M 12	3	12,3
0140	8000	1050	0,5203	4,50	7,0	330	400	44,0	128	250	157	40	5,0	138	225	8,0	M 16	3	31,2

* Max. angular displacement 3°.

** Arrangement of the fastening holes for screws Z (DIN EN ISO 4762) on pitch diameter T. The hole pattern of the respective other coupling half is offset by 90°.

Elastomer element	Material	Temperature range °C	Colour
HGW 2082	Cotton fabric-phenolic	up to +100	red

Arrangement of the fastening holes

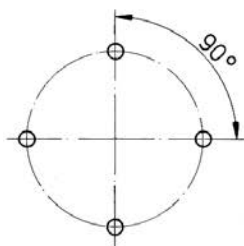

Hole pattern 1

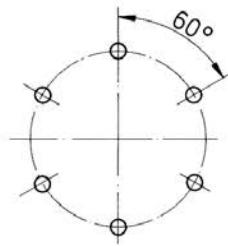

Hole pattern 2

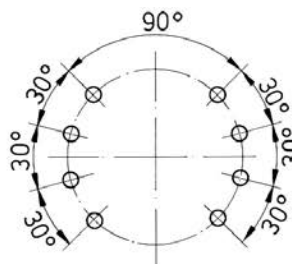

Hole pattern 3

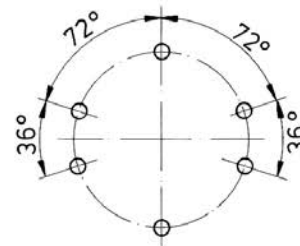

Hole pattern 4

Combination of hub designs



The design of the flexible coupling RDA ... ESO allows for the combination of various hub forms to suit available space.

	 Type 0	 Type I	 Type II
 Type 0	●	●	●
 Type I	●	●	
 Type II	●		●

Order example

Coupling design	RDA
Coupling size	0035
Type	ESO
Material of the hub: • Nodular cast iron	GJS
Hub A, type: • 0, standard	0
Hub A, design: • finish bored with keyway • roughbored	FB VA
Bore diameter hub A	028
Hub B, type: • II, flange hub	2
Hub B, design: • Mounting flange with through bore, arrangement of the fastening holes according to hole pattern	PE
Pitch diameter T hub B	065
Material of the compensation disc: • HGW 2082 in accordance with DIN 7735	HG82

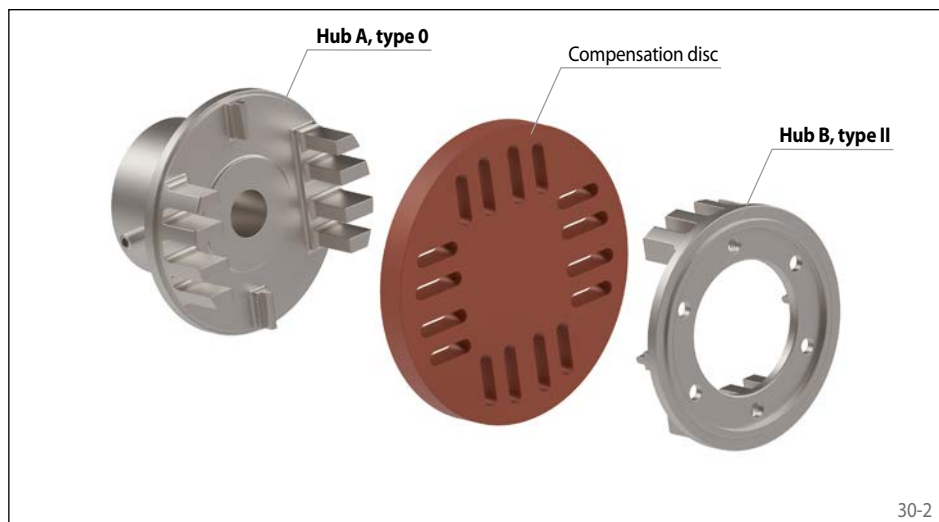

RDA 0035 ESO-GJS-0FB028-2PE065-HG82

Example hub combination

Hub with mounting flange – hub with keyway

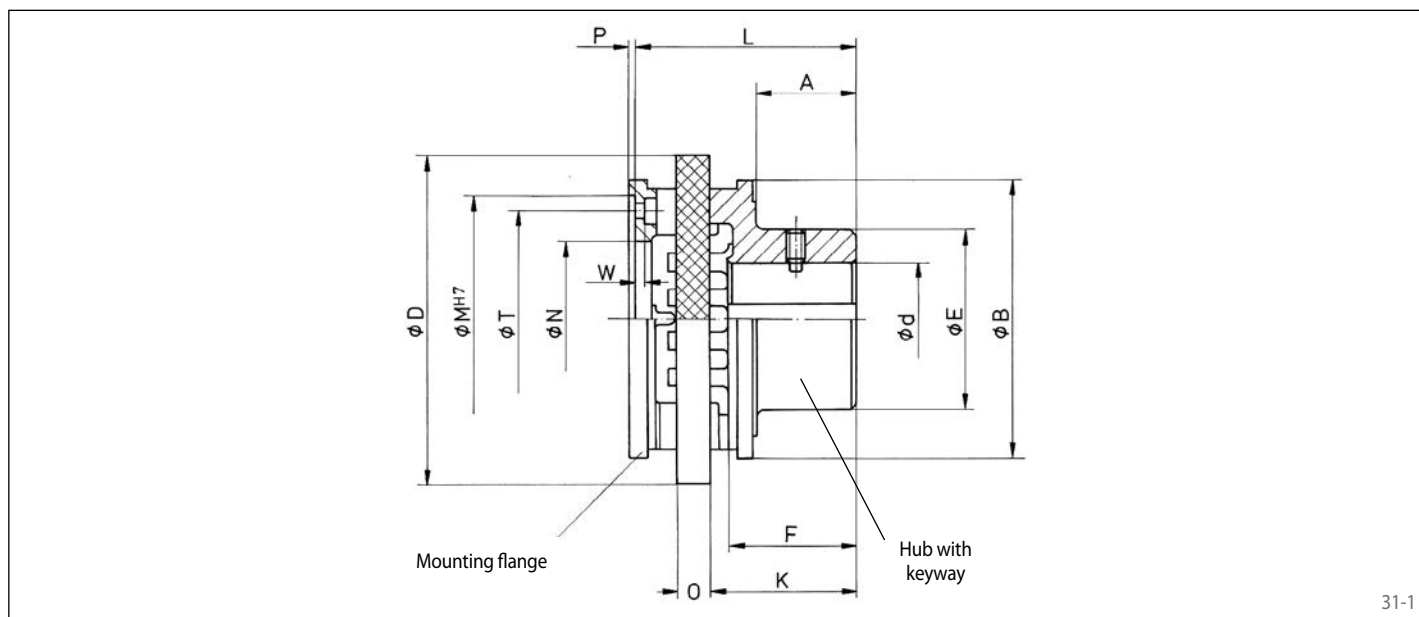

31-1

Coupling size	Max. torque T_{Kmax} Nm	Max. speed n_{max} min ⁻¹	Moment of inertia J_K kgm ²	Max. misalignments*		Pilot bore d mm	Finish bore d		A mm	B mm	D mm	E mm	F** mm	K mm	L mm	M ^{H7} mm	N mm	O mm	P mm	T mm	W mm	Z	Hole pattern***	Weight with rough bore kg
				Axial +/- mm	Radial mm		min. mm	max. mm																
0035	85	4100	0,0011	1,50	1,75	15	16	35	33	90	110	53	42	50,0	76,5	75	45	12	2,5	65	3,5	M 6	1	1,3
0042	190	3400	0,0032	1,50	2,1	19	20	42	41	110	135	66	53	61,0	90,5	90	52	14	2,5	75	4,5	M 6	2	2,6
0050	500	2670	0,0075	2,00	2,5	29	30	50	51	135	160	85	62	71,5	105,5	100	65	16	4,5	88	4,5	M 8	2	4,1
0051	500	2670	0,0074	2,00	2,5	29	30	50	51	135	160	85	62	71,5	105,0	125	76	16	3,0	108	5,0	M 8	3	4,0
0070	1000	2140	0,0203	2,00	3,5	33	34	70	65	163	200	104	79	90,0	131,0	135	90	20	4,0	115	5,5	M 10	2	7,7
0090	2000	1700	0,0782	2,50	4,5	48	50	90	81	202	250	150	100	111	162,5	170	104	25	4,5	150	7,0	M 10	4	18,0
0110	4000	1350	0,2113	4,00	5,5	58	60	110	101	254	315	175	124	140	204,0	200	146	32	5,0	180	5,0	M 12	3	31,6
0140	8000	1050	0,7485	4,50	7,0	72	75	140	130	330	400	216	160	181	265,0	250	157	40	5,0	225	8,0	M 16	3	67,6

Tolerance of finish bores H7. Keyways in accordance with DIN 6885, sheet 1. Keyway tolerance P9.

* Max. angular displacement 3°.

** The hub length F can be shortened, which would change the dimensions A, C, K and L accordingly.

*** Arrangement of the fastening holes for screws Z (DIN EN ISO 4762) on pitch diameter T for coupling half with flange mounting.

Arrangement of the fastening holes

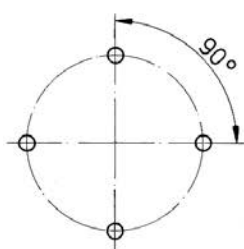

Hole pattern 1

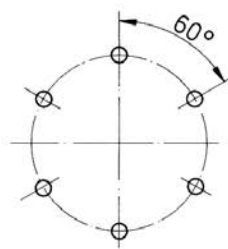

Hole pattern 2

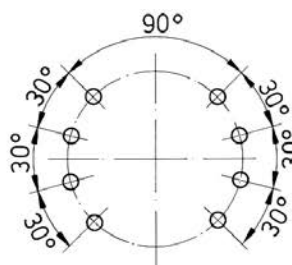

Hole pattern 3

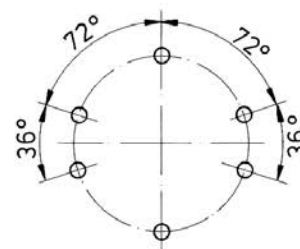

Hole pattern 4

elastic
horizontally split cover



32-1

Features

- High nominal torques up to 335 500 Nm
- Compensation of axial, radial and angular misalignments
- Gradual increase in torsional rigidity as torques increase
- Horizontally split cover
- Easy replacement of the grid
- Typical applications: Crushers, reels, mills, calenders, mixers, belt drives

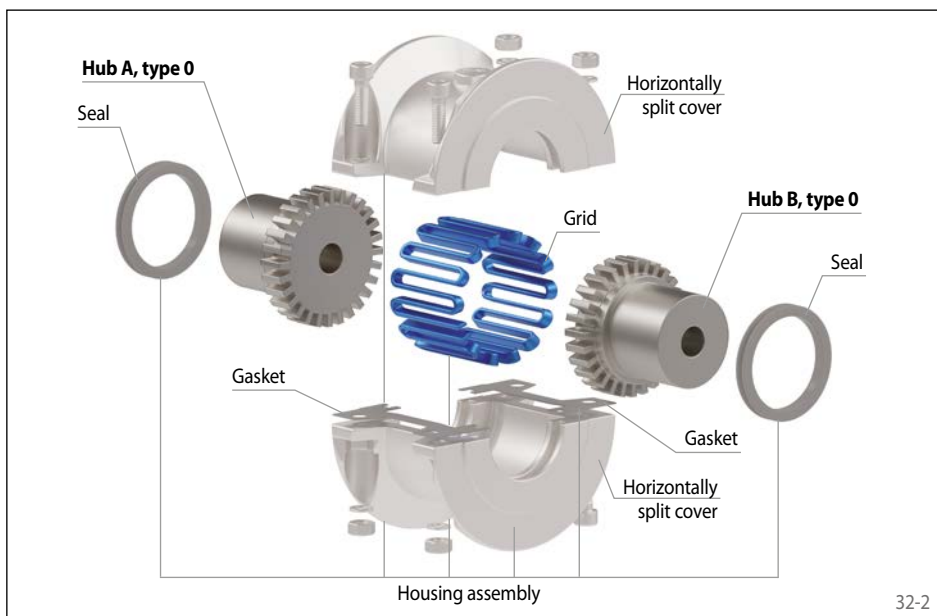

32-2



32-3

Order example

Order example	Code
Coupling design	RES
Coupling size	1030
Type	EYO
Material of the hub: • Steel	STA
Hub A, type: • 0, standard	0
Hub A, design: • finish bored with keyway • roughbored	FB VA
Bore diameter hub A	025
Hub B, type: • 0, standard	0
Hub B, design: • finish bored with keyway • roughbored	FB VA
Bore diameter hub B	032
Grid	ST00

RES 1030 EYO-STA-0FB025-0FB032-ST00

elastic
horizontally split cover

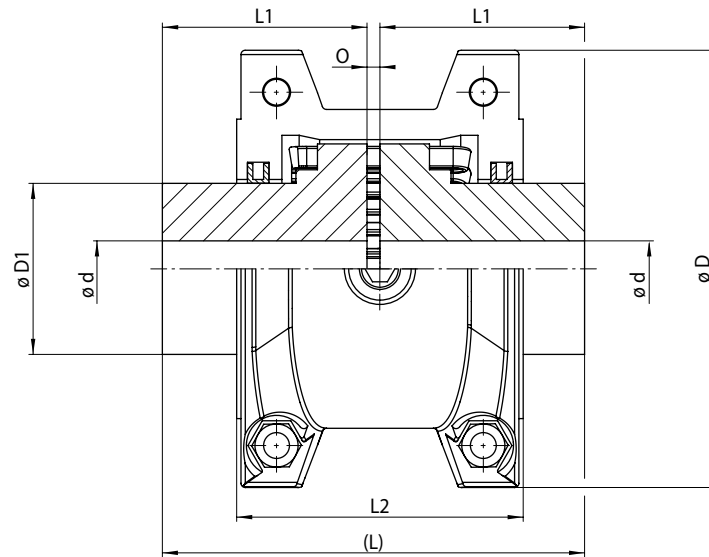

33-1

Coupling size	Nominal torque T_{KN} Nm	Nominal power at 100 min^{-1} P_{K100} kW	Max. speed n_{max} min^{-1}	Pilot bore d^* mm	Bore d^*		D mm	D1 mm	L mm	L1 mm	L2 mm	O mm	Permissible misalignments			Weight grease filling kg	Weight with max. bore kg
					min. mm	max. mm							Axial mm	Radial mm	Angular °		
1020	48	0,50	4500	-	13	28	101,5	39,7	98,0	47,5	66,5	3,0	±0,3	0,3	0,25	0,03	1,9
1030	136	1,42	4500	-	13	35	110,0	49,2	98,0	47,5	68,0	3,0	±0,3	0,3	0,25	0,03	2,6
1040	226	2,36	4500	-	13	43	117,5	57,1	104,5	51,0	70,0	3,0	±0,3	0,3	0,25	0,05	3,4
1050	395	4,14	4500	-	13	50	138,0	66,7	123,5	60,0	79,5	3,0	±0,3	0,4	0,25	0,05	5,4
1060	620	6,50	4350	-	20	56	150,5	76,2	130,0	63,5	92,0	3,0	±0,3	0,4	0,25	0,09	7,3
1070	900	9,46	4125	-	20	67	162,0	87,3	155,5	76,0	95,0	3,0	±0,3	0,4	0,25	0,11	10,0
1080	1860	19,51	3600	-	27	80	194,0	104,8	181,0	89,0	116,0	3,0	±0,3	0,4	0,25	0,17	18,0
1090	3380	35,47	3600	-	27	95	213,0	123,8	200,0	98,5	122,0	3,0	±0,3	0,4	0,25	0,25	25,0
1100	5700	59,71	2400	-	42	110	250,0	142,0	245,5	120,5	155,5	4,5	±0,45	0,4	0,25	0,43	42,0
1110	8400	88,67	2250	-	42	120	270,0	160,3	258,5	127,0	161,5	4,5	±0,45	0,5	0,25	0,51	54,0
1120	12400	130,05	2025	57	61	140	308,0	179,4	304,5	149,5	191,5	6,0	±0,6	0,5	0,25	0,73	81,0
1130	18000	189,17	1800	57	67	170	346,0	217,5	330,0	162,0	195,0	6,0	±0,6	0,56	0,25	0,91	121
1140	25900	271,93	1650	57	67	200	384,0	254,0	371,5	183,0	201,0	6,0	±0,6	0,56	0,25	1,13	178
1150	36100	378,34	1500	57	108	215	453,0	269,2	372,0	183,0	271,0	6,0	±0,6	0,56	0,25	1,95	234
1160	50500	532,04	1350	57	121	240	501,5	304,8	402,0	198,0	279,0	6,0	±0,6	0,6	0,25	2,81	317
1170	67500	709,38	1225	65	134	280	566,5	355,6	438,0	216,0	304,0	6,0	±0,6	0,6	0,25	3,49	448
1180	93500	983,68	1100	105	153	300	630,0	393,7	483,5	239,0	321,0	6,0	±0,6	0,76	0,25	3,76	619
1190	124000	1300,53	1050	105	153	335	675,5	436,9	524,5	259,0	325,0	6,0	±0,6	0,76	0,25	4,40	776
1200	169000	1773,46	900	105	178	360	757,0	497,8	565,0	279,5	355,5	6,0	±0,6	0,76	0,25	5,62	1058
1210	248500	2605,47	820	105	178	390	844,5	533,4	622,5	305,0	432,0	12,7	±0,6	0,76	0,25	10,5	1424
1220	335500	3515,89	730	105	203	420	920,5	571,5	663,0	325,1	490,0	12,7	±0,6	0,76	0,25	16,1	1785

For finish bores, please specify bore diameter hub A and hub B. Tolerance of finish bores H7. Keyways in accordance with DIN 6885, sheet 1. Keyway tolerance JS9.
* Bores also available in inch size, see page 73.

elastic
vertically split cover

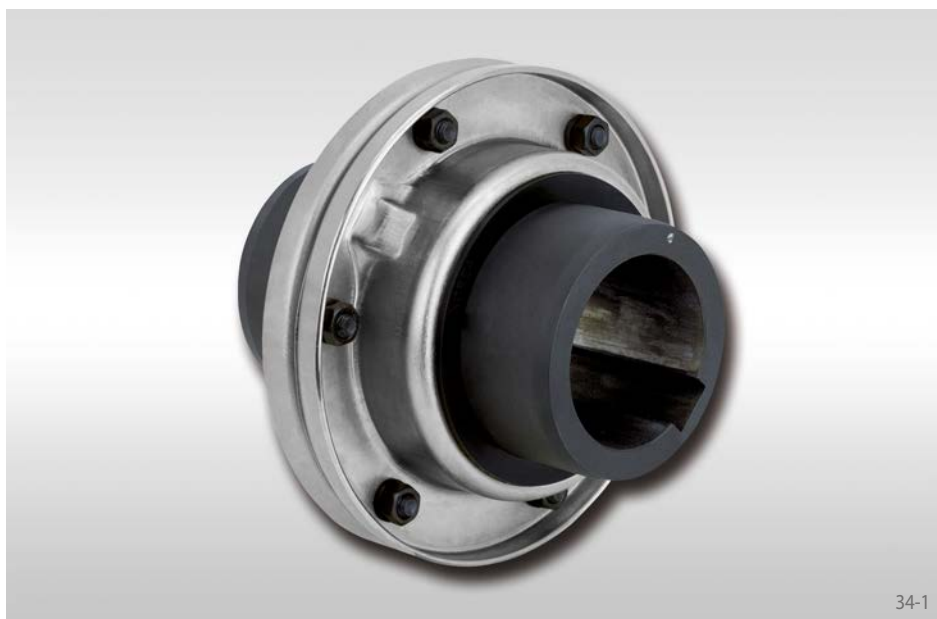

34-1

Features

- Nominal torques up to 169 000 Nm
- Compensation of axial, radial and angular misalignments
- Gradual increase in torsional rigidity as torques increase
- Vertically split cover
- Easy replacement of the grid
- Typical applications: Crushers, reels, mills, calenders, mixers, belt drives

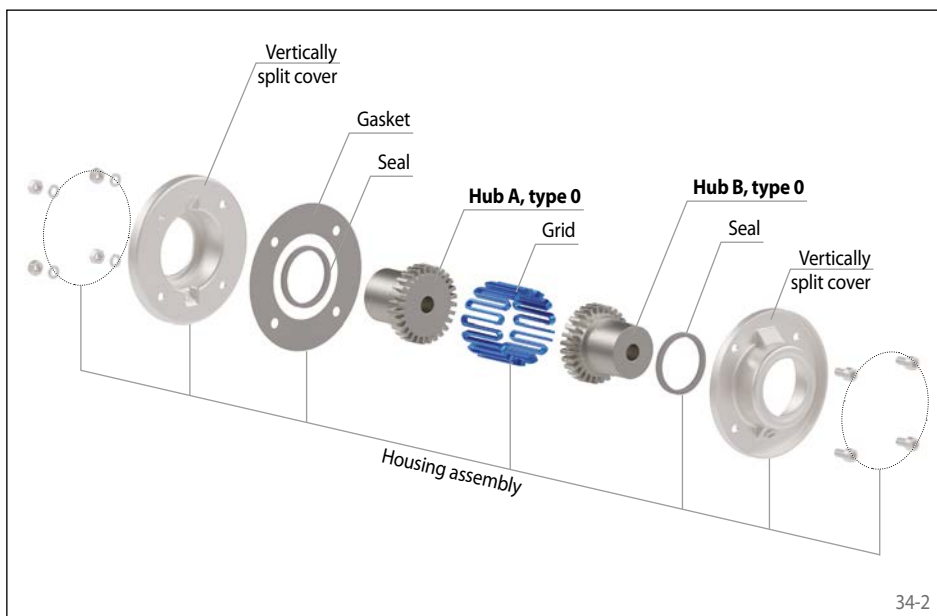

34-2

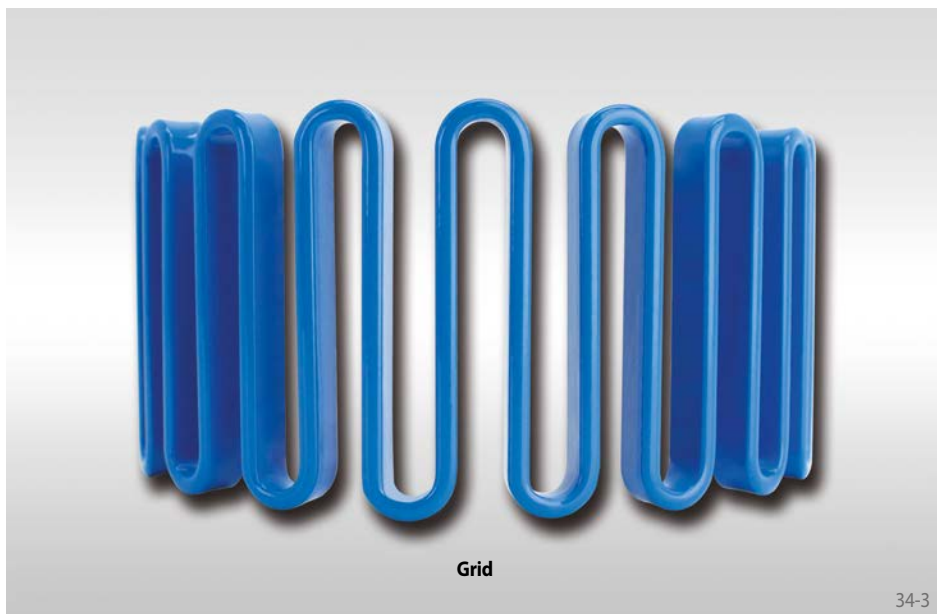

Grid

34-3

Order example

Order example	Code
Coupling design	RES
Coupling size	1030
Type	ETO
Material of the hub: • Steel	STA
Hub A, type: • 0, standard	0
Hub A, design: • finish bored with keyway • roughbored	FB VA
Bore diameter hub A	025
Hub B, type: • 0, standard	0
Hub B, design: • finish bored with keyway • roughbored	FB VA
Bore diameter hub B	032
Grid	ST00

RES 1030 ETO-STA-0FB025-0FB032-ST00

elastic
vertically split cover

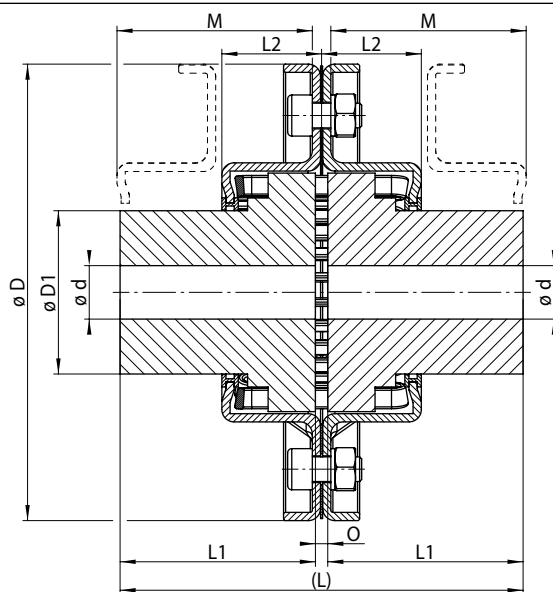

35-1

Coupling size	Nominal torque T_{KN} Nm	Nominal power at 100 min^{-1} P_{K100} kW	Max. speed n_{max} min^{-1}	Pilot bore d^* mm	Bore d^*		D mm	D1 mm	L mm	L1 mm	L2 mm	M** mm	O mm	Permissible misalignments			Weight grease filling kg	Weight with max. bore kg
					min. mm	max. mm								Axial mm	Radial mm	Angular °		
1020	48	0,50	6000	-	13	28	111,0	39,7	98,0	47,5	24,0	47,5	3,0	±0,3	0,3	0,03	2,0	
1030	136	1,40	6000	-	13	35	121,0	49,2	98,0	47,5	25,0	47,5	3,0	±0,3	0,3	0,03	2,6	
1040	226	2,30	6000	-	13	43	128,5	57,1	104,5	51,0	25,5	51,0	3,0	±0,3	0,3	0,05	3,4	
1050	395	4,10	6000	-	13	50	147,5	66,7	123,5	60,5	31,0	60,5	3,0	±0,3	0,4	0,05	5,4	
1060	620	6,49	6000	-	20	56	162,0	76,2	130,0	63,5	32,0	63,5	3,0	±0,3	0,4	0,09	7,3	
1070	900	9,39	5500	-	20	67	173,0	87,3	155,5	76,0	33,5	76,0	3,0	±0,3	0,4	0,11	10,4	
1080	1860	19,48	4750	-	27	80	200,0	104,8	181,0	89,0	44,0	89,0	3,0	±0,3	0,4	0,17	17,7	
1090	3380	34,96	4000	-	27	95	232,0	123,8	200,0	98,5	47,5	98,5	3,0	±0,3	0,4	0,25	25,4	
1100	5700	59,44	3250	-	42	110	267,0	142,0	245,5	120,5	60,0	120,5	4,5	±0,45	0,4	0,43	42,2	
1110	8400	87,90	3000	-	42	120	286,0	160,3	258,5	127,0	64,0	127,0	4,5	±0,45	0,5	0,51	54,4	
1120	12400	129,86	2700	57	61	140	319,0	179,4	304,5	149,0	73,5	149,0	6,0	±0,6	0,5	0,73	81,6	
1130	18000	188,79	2400	57	67	170	378,0	217,5	330,0	162,0	75,0	162,0	6,0	±0,6	0,56	0,91	122,5	
1140	25900	271,70	2200	57	67	200	416,0	254,0	371,5	183,0	78,0	183,0	6,0	±0,6	0,56	1,13	180,1	
1150	36100	378,59	2000	57	108	215	476,5	269,2	372,0	183,0	107,0	183,0	6,0	±0,6	0,56	1,95	230,0	
1160	50500	532,40	1750	57	121	240	533,5	304,8	402,0	198,0	114,5	198,0	6,0	±0,6	0,6	2,81	321,1	
1170	67500	709,38	1600	65	134	280	584,0	355,6	438,0	216,0	120,0	216,0	6,0	±0,6	0,6	3,49	448,2	
1180	93500	983,68	1400	105	153	300	630,0	393,7	483,5	239,0	130,0	239,0	6,0	±0,6	0,76	3,76	591,0	
1190	124000	1300,53	1300	105	153	335	685,0	436,9	524,0	260,0	135,0	259,0	6,0	±0,6	0,76	4,4	761,0	
1200	169000	1773,46	1100	105	178	360	737,0	497,8	565,0	279,5	145,0	279,5	6,0	±0,6	0,76	5,62	1021,0	

For finish bores, please specify bore diameter hub A and hub B. Tolerance of finish bores H7. Keyways in accordance with DIN 6885, sheet 1. Keyway tolerance JS9.

* Bores also available in inch size, see page 73.

** Minimum necessary space to align the shafts.

elastic
lubrication-free



Features

- Vertical/horizontal mounting
- Adsorbs vibrations
- Progressive torsion spring properties due to primarily pressurised bushings
- Fail-safe in the event of the failure of the bushings
- Easy replacement of bushings without disassembly of the coupling halves
- Maintenance free, no lubrication necessary
- Complies with ATEX 2014/34/EU
- Typical applications: Pump drives, belt drives, ventilators, general mechanical engineering

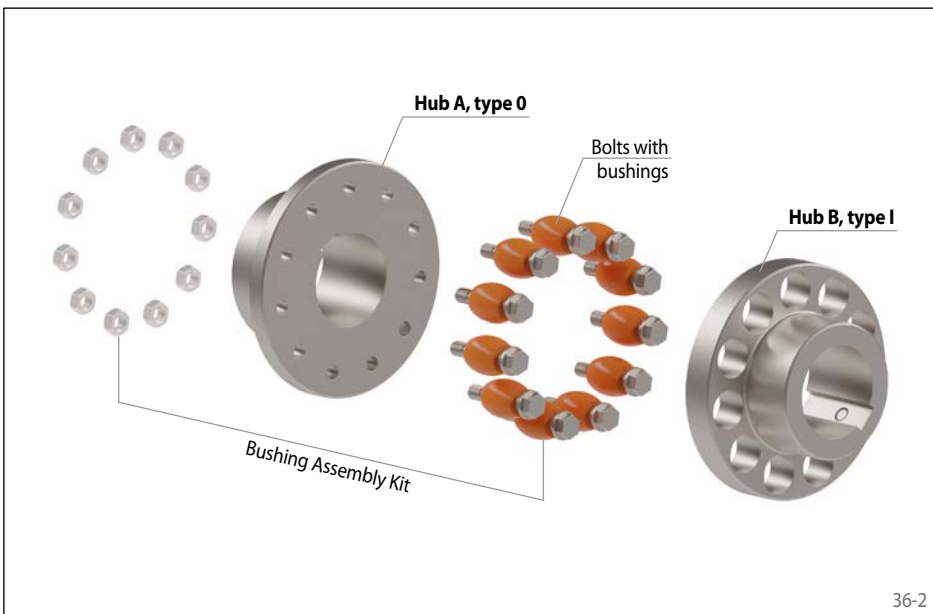

Order example

Order example	Code
Coupling design	REB
Coupling size	0105
Type	DCO
Material of the hub:	GJL
• Cast iron	
Hub A, type:	
• 0, standard, pin hub (up to size 0360)	0
• II, standard, pin and bush hub (from size 0410)	2
Hub A, design:	
• finish bored with keyway	FB
• roughbored	VA
Bore diameter hub A	030
Hub B, type:	
• I, standard, bush hub (up to size 0360)	1
• II, standard, pin and bush hub (from size 0410)	2
Hub B, design:	
• finish bored with keyway	FB
• roughbored	VA
Bore diameter hub B	028
Material of bushings:	
• NR 80 Shore-A	NR80
• PU 92 Shore-A	PU92
• HTrans	HT00



REB 0105 DCO-GJL-0FB030-1FB028-NR80

elastic
lubrication-free

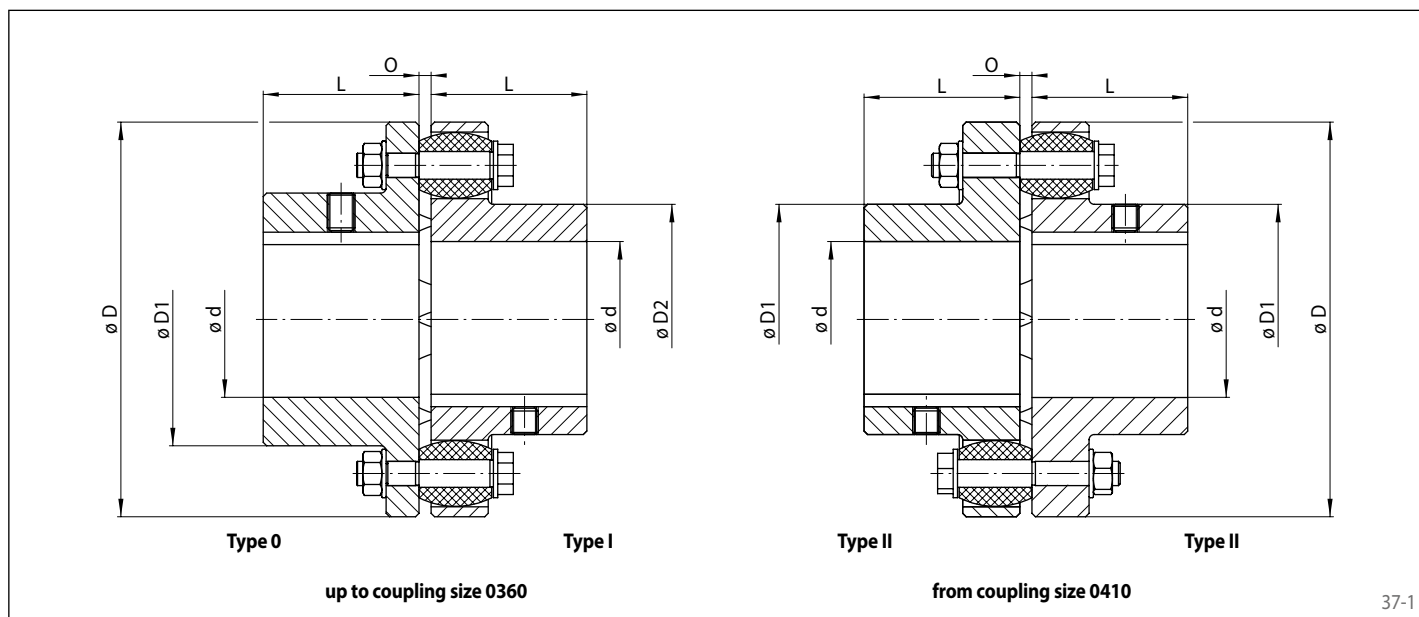

37-1

Coupling size	Max. speed n_{max} min ⁻¹	Moment of inertia with max. bore J_k kgm ²	Pilot bore d^* mm	Min. bore d^*			Max. bore d^*			D mm	D1 mm	D2 mm	L mm	O mm	Permissible misalignments			Weight with max. bore kg
				Hub type 0 mm	Hub type I mm	Hub type II mm	Hub type 0 mm	Hub type I mm	Hub type II mm						Axial mm	Radial mm	Angular °	
0105	7200	0,003	13	15	15	-	32	30	-	105	50	48	45	2-6	2	0,3	1	2
0116	6100	0,005	13	15	15	-	42	39	-	116	68	60	45	2-6	2	0,3	1	2,6
0125	5500	0,007	13	15	15	-	50	45	-	125	78	68	50	2-6	2	0,4	1	3,1
0144	4900	0,012	16	18	18	-	60	50	-	144	91	82	55	2-6	2	0,4	1	4,3
0162	4500	0,030	20	22	22	-	65	60	-	162	100	89	60	2-6	2	0,4	1	7,5
0178	3800	0,040	22	24	24	-	75	70	-	178	115	105	70	2-6	2	0,5	1	10
0198	3400	0,062	26	28	28	-	90	80	-	198	135	124	80	2-6	2	0,5	1	13
0228	3000	0,10	26	28	28	-	100	90	-	228	146	133	90	4-10	3	0,6	1	18
0252	2700	0,17	36	38	38	-	115	105	-	252	167	156	100	4-10	3	0,6	1	24
0285	2400	0,31	46	48	48	-	125	115	-	285	186	170	110	4-10	3	0,7	1	35
0320	2100	0,53	53	55	55	-	135	125	-	320	212	196	125	4-10	3	0,7	1	51
0360	1900	1,02	63	65	65	-	150	135	-	360	232	212	140	4-12	4	0,9	1	73
0410	1700	1,70	73	-	-	75	-	-	160	410	230	-	160	4-12	4	1,1	1	101
0450	1500	2,90	83	-	-	85	-	-	180	450	260	-	180	4-12	4	1,1	0,5	137
0500	1350	4,70	93	-	-	95	-	-	200	500	290	-	200	4-12	4	1,1	0,4	180
0560	1200	10,7	93	-	-	95	-	-	225	560	320	-	220	4-8	2	1,5	0,3	278
0630	1050	17,4	98	-	-	100	-	-	250	630	355	-	240	4-8	2	1,5	0,3	365
0710	950	33,0	98	-	-	100	-	-	260	710	385	-	260	5-9	2	1,8	0,3	516
0800	850	53,0	98	-	-	100	-	-	280	800	420	-	290	5-9	2	1,8	0,3	691
0900	750	86,0	98	-	-	100	-	-	305	900	465	-	320	5-9	2	1,8	0,3	927
1000	680	142,8	115	-	-	125	-	-	320	1000	515	-	350	5-10	2	2,0	0,1	1224
1120	600	231,0	125	-	-	135	-	-	350	1120	560	-	380	6-11	2	2,2	0,1	1584
1250	550	367,5	140	-	-	150	-	-	380	1250	610	-	420	6-11	2	2,4	0,1	2070
1400	490	693,0	165	-	-	175	-	-	440	1400	700	-	480	6-12	2	2,7	0,1	3060
1600	430	1155	190	-	-	200	-	-	480	1600	770	-	540	6-12	2	3,0	0,1	3960
1800	380	2205	215	-	-	225	-	-	540	1800	870	-	600	8-16	2	3,4	0,1	5760
2000	340	3255	240	-	-	250	-	-	600	2000	960	-	660	8-16	2	3,8	0,1	7020

For finish bores, please specify bore diameter hub A and hub B. Tolerance of finish bores H7. Keyways in accordance with DIN 6885, sheet 1. Keyway tolerance JS9. The couplings can be momentarily overloaded at start-up by up to three times the nominal torque.

For vertical installation, please contact RINGSPANN.

See following pages for performance data.

* Bores also available in inch size, see page 73.

Bushings



Bushing NR 80 Shore-A

Material: Natural rubber
 Hardness: 80 ±5 Shore -A
 Temperature range: -45 °C to +70 °C
 Colour: black



Bushing PU 92 Shore-A

Material: Polyurethane
 Hardness: 92 ±5 Shore-A
 Temperature range: -30 °C to +80 °C
 Colour: orange

Coupling size	Nominal torque T_{KN} Nm	Nominal power at 100 min^{-1} P_{K100} kW	Max. torque $T_{K \text{ max}}$ Nm	Alternating torque T_{KW} Nm	Torsional stiffness $C_{T \text{ dyn}}$ Nm/rad x 10^3			Relative damping ψ at 0,5 T_{KN}
					1,0	0,5	0,25	
					T_{KN}	T_{KN}	T_{KN}	
0105	95	1,0	285	19	12	6	5	1,4
0116	146	1,5	438	29	21	11	8	
0125	166	1,7	498	33	27	14	10	
0144	318	3,3	954	64	59	32	22	
0162	520	5,5	1570	105	88	47	33	
0178	640	6,7	1920	129	126	70	37	
0198	1240	13	3740	250	279	155	82	
0228	2050	21	6100	410	406	225	119	
0252	3060	32	9200	614	689	382	202	
0285	4550	48	13600	910	1052	547	272	
0320	6000	64	18200	1220	5045	1894	814	
0360	8900	93	26700	1780	6653	2498	1073	
0410	12000	126	36100	2410	8066	3029	1301	
0450	18600	195	55500	3720	13973	5247	2254	
0500	25800	270	77000	5160	21481	8066	3465	
0560	31000	325	93000	6201	19199	7209	3097	
0630	41900	440	125500	8400	29671	11141	4786	
0710	75000	785	225000	15000	45968	17260	7415	
0800	100000	1047	300000	20000	69131	25957	11151	
0900	154500	1623	464500	31000	119868	45008	19335	
1000	194500	2042	584500	38999	172799	64883	27873	
1120	269500	2827	809500	53999	224141	84161	36155	
1250	344500	3613	1034500	68999	317491	119212	51213	
1400	529500	5550	1589500	106000	488695	183496	78829	
1600	749500	7854	2249500	149999	776595	291597	125269	
1800	974500	10210	2924500	194999	1020539	383193	164618	
2000	1299500	13614	3899500	259999	1511459	567524	243806	

Coupling size	Nominal torque T_{KN} Nm	Nominal power at 100 min^{-1} P_{K100} kW	Max. torque $T_{K \text{ max}}$ Nm	Alternating torque T_{KW} Nm	Torsional stiffness $C_{T \text{ dyn}}$ Nm/rad x 10^3			Relative damping ψ at 0,5 T_{KN}
					1,0	0,5	0,25	
					T_{KN}	T_{KN}	T_{KN}	
0105	143	1,5	429	29	11	9	6	0,5
0116	220	2,3	660	44	20	16	10	
0125	248	2,6	740	50	25	20	13	
0144	478	5,0	1430	96	55	44	30	
0162	790	8,3	2370	159	82	65	45	
0178	960	10,1	2890	193	105	85	62	
0198	1860	19,5	5500	372	230	186	136	
0228	3000	31,5	9000	602	326	264	193	
0252	4580	48,0	13700	917	562	455	333	
0285	6800	72,0	20600	1375	893	721	559	
0320	9100	96,0	27500	1834	2035	1093	686	
0360	13300	139,5	39900	2664	2660	1429	897	
0410	18000	189,0	54000	3610	3225	1732	1088	
0450	27900	292,5	83500	5587	5651	3034	1906	
0500	38600	405,0	116000	7736	8687	4665	2930	
0560	46500	487,5	139500	9311	7764	4169	2619	
0630	63000	660,0	189000	12606	11999	6443	4048	
0710	112000	1177,5	337000	22490	18590	9982	6271	
0800	149500	1570,5	449500	29997	27957	15012	9431	
0900	232000	2434,5	697000	46499	48475	26030	16353	
1000	292500	3063,0	877500	58503	69881	37524	23574	

Bushings



Bushing HTrans

Material: Polyurethane
 Hardness: 55 ±2 Shore-D
 Temperature range: -30 °C to +120 °C
 Colour: white

Coupling size	Nominal torque T_{KN} Nm	Nominal power at 100 min^{-1} P_{K100} kW	Max. torque T_{Kmax} Nm	Alternating torque T_{KW} Nm	Torsional stiffness $C_{T \text{ dyn}}$ Nm/rad x 10^3			Relative damping ψ at 0,5 T_{KN}
					1,0 T_{KN}	0,5 T_{KN}	0,25 T_{KN}	
0105	287	3	860	57	28	25	20	0,43
0116	382	4	1140	76	43	38	31	
0125	382	4	1140	76	48	42	34	
0144	760	8	2290	153	110	96	79	
0162	1330	14	4010	267	172	150	123	
0178	1620	17	4870	325	213	186	151	
0198	3150	33	9400	630	471	411	335	
0228	5000	53	15100	1012	668	583	475	
0252	7600	80	22900	1528	1143	997	813	
0285	11400	120	34300	2292	1444	1197	952	
0320	15200	160	45800	3056	2159	1790	1424	
0360	22200	233	66500	4450	2836	2351	1871	

torsional elastic
with brake disc

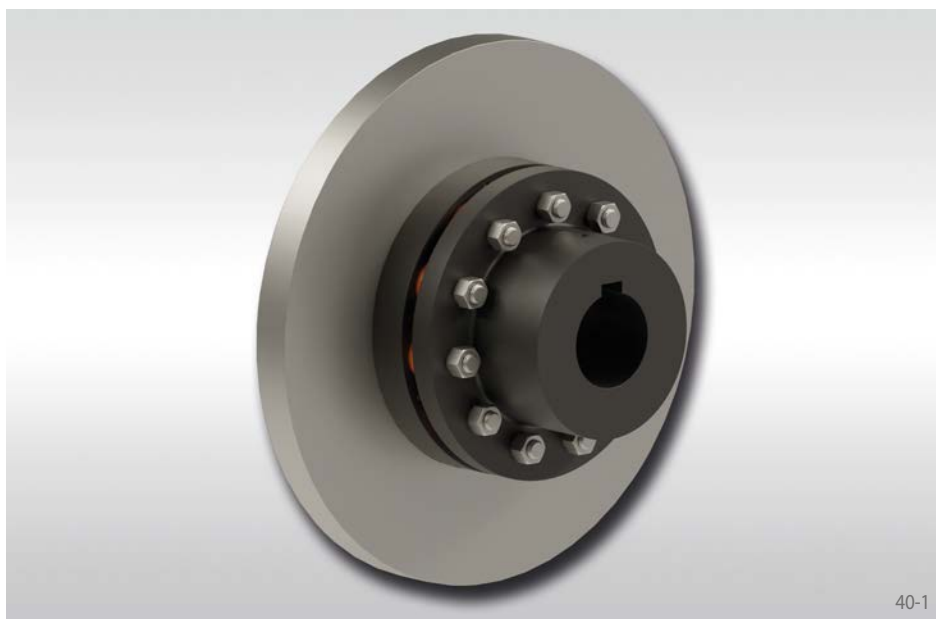

40-1

Features

- Nominal torques up to 112 000 Nm
- Compensation of axial, radial and angular misalignments
- Coupling and brake disc matched to RINGSPANN brake systems
- Adsorbs vibrations
- Fail-safe in the event of the failure of the bushings
- Easy replacement of bushings without disassembly of the coupling halves
- Maintenance free, no lubrication necessary
- Typical applications: Belt drives, ventilators, general mechanical engineering

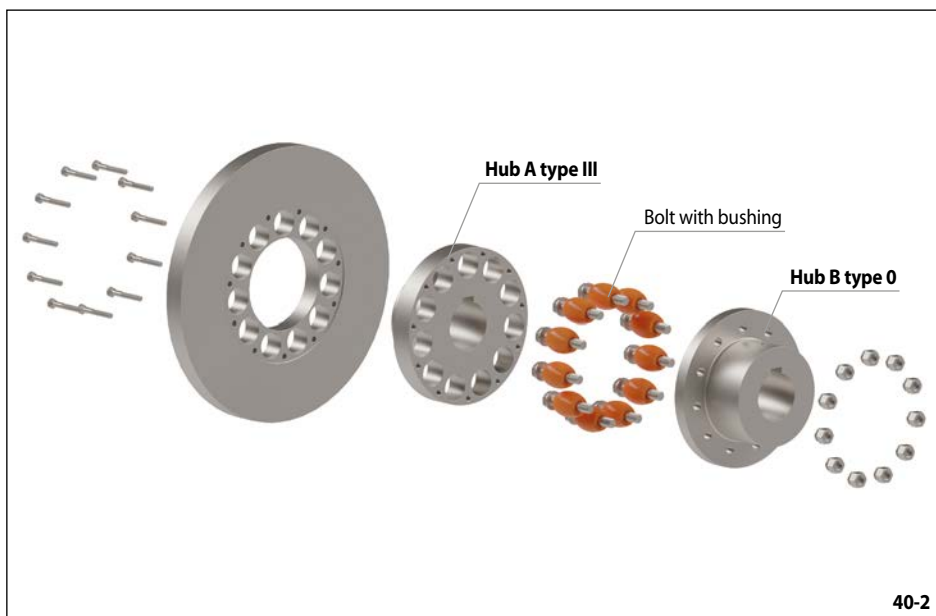

40-2



NR 80 Shore-A

PU 92 Shore-A

HTrans

Bushings

40-3

Order example

Order example	Code
Coupling design	REB
Coupling size	0228
Type	DCS
Material of the hub:	GJL
• Cast iron	
Hub A, type:	
• 0, standard, pin hub (up to size 0360)	0
• II, standard, pin and bush hub (from size 0410)	2
Hub A, design:	
• finish bored with keyway	FB
• roughbored	VA
Bore diameter hub A	080
Hub B, type:	
• III, with brake disc, bush hub (up to size 0360)	3
• IV, with brake disc, pin and bush hub (from size 0410)	4
Hub B, design:	
• finish bored with keyway	FB
• roughbored	VA
Bore diameter hub B	060
Material of bushings:	
• NR 80 Shore-A	NR80
• PU 92 Shore-A	PU92
• HTrans	HT00
Brake disc size and material *	SOKE

REB 0228 DCS-GJL-0FB080-3FB060-NR80-SOKE

* see table "Brake discs and order code"

torsional elastic
with brake disc

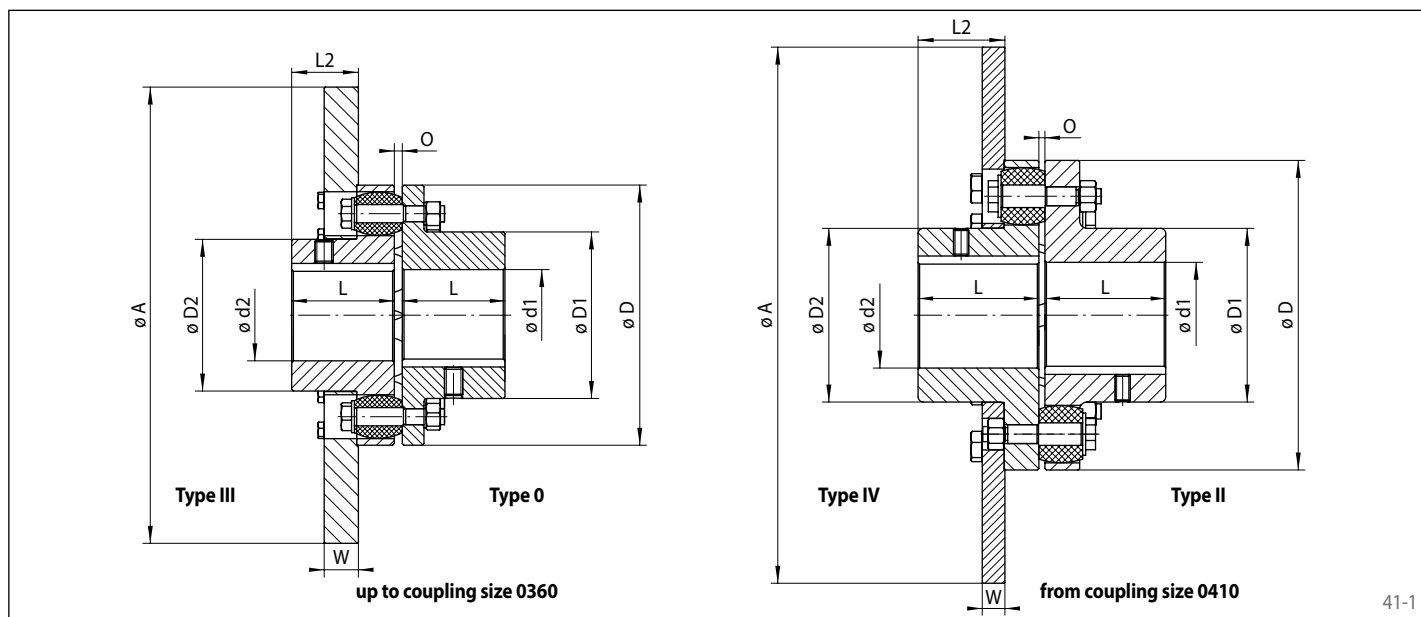

41-1

Coupling size	Max. speed n_{max} min ⁻¹	Pilot bore d1/d2 mm	Min. bore d1/d2			Max. bore d1/d2			D mm	D1 mm	D2 mm	L mm	O mm	Permissible misalignments		
			Hub type 0 mm	Hub type II mm	Hub type III + IV (with brake disc) mm	Hub type 0 mm	Hub type II mm	Hub type III + IV (with brake disc) mm						Axial mm	Radial mm	Angular °
0228	3000	26	28	-	28	100	-	90	228	146	133	90	4-10	3,0	0,60	1,0
0252	2700	36	38	-	38	115	-	105	252	167	156	100	4-10	3,0	0,60	1,0
0285	2400	46	48	-	48	125	-	115	285	186	170	110	4-10	3,0	0,70	1,0
0320	2100	53	55	-	55	135	-	125	320	212	196	125	4-10	3,0	0,70	1,0
0360	1900	63	65	-	65	150	-	135	360	232	212	140	4-12	4,0	0,90	1,0
0410	1700	73	-	75	75	-	160	160	410	230	-	160	4-12	4,0	1,10	1,0
0450	1500	86	-	85	85	-	180	180	450	260	-	180	4-12	4,0	1,10	0,5
0500	1350	93	-	95	95	-	200	200	500	290	-	200	4-12	4,0	1,10	0,4
0560	1200	93	-	95	95	-	225	225	560	320	-	220	4-8	2,0	1,50	0,3
0630	1050	98	-	100	100	-	250	250	630	355	-	240	4-8	2,0	1,50	0,3
0710	950	98	-	100	100	-	260	260	710	385	-	260	5-9	2,0	1,80	0,3

Brake discs and ordering code

Material	$\phi A \times W$ mm	Coupling size														
		0228	0252	0285	0320	0360	0410	0450	0500	0560	0630	0710				
Steel	400 x 30	SOFE														
	450 x 30	SOHE	SOHE	SOHE												
	500 x 30	SOIE	SOIE	SOIE	SOIE											
	560 x 30	SOKE	SOKE	SOKE	SOKE	SOKE										
	630 x 30		SOLE	SOLE	SOLE	SOLE	SOLE	SOLE								
	710 x 30				SOME	SOME	SOME	SOME	SOME							
	800 x 30							SONE	SONE	SONE						
	900 x 30									SOOE	SOOE					
Nodular cast iron	1000 x 30									SOPE	SOPE					
	300 x 12,5	G0CA	G0CA													
	355 x 12,5	G0EA	G0EA	G0EA												
	355 x 25	G0ED	G0ED	G0ED												
	430 x 12,5	G0GA	G0GA	G0GA	G0GA	G0GA										
	430 x 25			G0GD	G0GD	G0GD										
	520 x 12,5				G0JA	G0JA	G0JA									
	520 x 25				G0JD	G0JD	G0JD									
	630 x 25					G0LD	G0LD	G0LD	G0LD	G0LD						
	710 x 25							G0MD	G0MD	G0MD	G0MD					
800 x 25							G0ND	G0ND	G0ND	G0ND	G0ND					
900 x 25									GOOD	GOOD	GOOD	GOOD				
1000 x 25									G0PD	G0PD	G0PD	G0PD	G0PD	G0PD	G0PD	G0PD

Bushings



Bushing NR 80 Shore-A

Material: Natural rubber
 Hardness: 80 ±5 Shore -A
 Temperature range: -45 °C to +70 °C
 Colour: black



Bushing PU 92 Shore-A

Material: Polyurethane
 Hardness: 92 ±5 Shore-A
 Temperature range: -30 °C to +80 °C
 Colour: orange

Coupling size	Nominal torque T_{KN} Nm	Nominal power at 100 min^{-1} P_{K100} kW	Max. torque $T_{K \text{ max}}$ Nm	Alternating torque T_{KW} Nm	Torsional stiffness $C_{T \text{ dyn}}$ Nm/rad x 10^3			Relative damping ψ at 0,5 T_{KN}
					1,0 T_{KN}	0,5 T_{KN}	0,25 T_{KN}	
0228	2050	21	6100	410	406	225	119	1,4
0252	3060	32	9200	614	689	382	202	
0285	4550	48	13600	910	1052	547	272	
0320	6000	64	18200	1220	5045	1894	814	
0360	8900	93	26700	1780	6653	2498	1073	
0410	12000	126	36100	2410	8066	3029	1301	
0450	18600	195	55500	3720	13973	5247	2254	
0500	25800	270	77000	5160	21481	8066	3465	
0560	31000	325	93000	6201	19199	7209	3097	
0630	41900	440	125500	8400	29671	11141	4786	
0710	75000	785	225000	15000	45968	17260	7415	

Coupling size	Nominal torque T_{KN} Nm	Nominal power at 100 min^{-1} P_{K100} kW	Max. torque $T_{K \text{ max}}$ Nm	Alternating torque T_{KW} Nm	Torsional stiffness $C_{T \text{ dyn}}$ Nm/rad x 10^3			Relative damping ψ at 0,5 T_{KN}
					1,0 T_{KN}	0,5 T_{KN}	0,25 T_{KN}	
0228	3000	31,5	9000	602	326	264	193	0,5
0252	4580	48,0	13700	917	562	455	333	
0285	6800	72,0	20600	1375	893	721	559	
0320	9100	96,0	27500	1834	2035	1093	686	
0360	13300	139,5	39900	2664	2660	1429	897	
0410	18000	189,0	54000	3610	3225	1732	1088	
0450	27900	292,5	83500	5587	5651	3034	1906	
0500	38600	405,0	116000	7736	8687	4665	2930	
0560	46500	487,5	139500	9311	7764	4169	2619	
0630	63000	660,0	189000	12606	11999	6443	4048	
0710	112000	1177,5	337000	22490	18590	9982	6271	

Bushings



Bushing HTrans

Material: Polyurethane
 Hardness: 55 ±2 Shore-D
 Temperature range: -30 °C to +120 °C
 Colour: white

Coupling size	Nominal torque T_{KN} Nm	Nominal power at 100 min^{-1} P_{K100} kW	Max. torque T_{Kmax} Nm	Alternating torque T_{KW} Nm	Torsional stiffness $C_{T \text{ dyn}}$ Nm/rad x 10^3			Relative damping ψ at 0,5 T_{KN}
					1,0 T_{KN}	0,5 T_{KN}	0,25 T_{KN}	
0228	5000	53	15100	1012	668	583	475	0,43
0252	7600	80	22900	1528	1143	997	813	
0285	11400	120	34300	2292	1444	1197	952	
0320	15200	160	45800	3056	2159	1790	1424	
0360	22200	233	66500	4450	2836	2351	1871	

Jaw Couplings REK ... DGO

elastic for dynamic applications
with enclosed elastic elements



44-1

Features

- Compensation of axial, radial and angular misalignments
- Adsorbs vibrations
- Progressive torsion spring properties due to primarily pressurised elastic elements
- Fail-safe in the event of the failure of the elastic elements
- Maintenance free, no lubrication necessary
- Complies with ATEX 2014/34/EU
- Typical applications: Pump drives, ventilator drives, crane trolleys

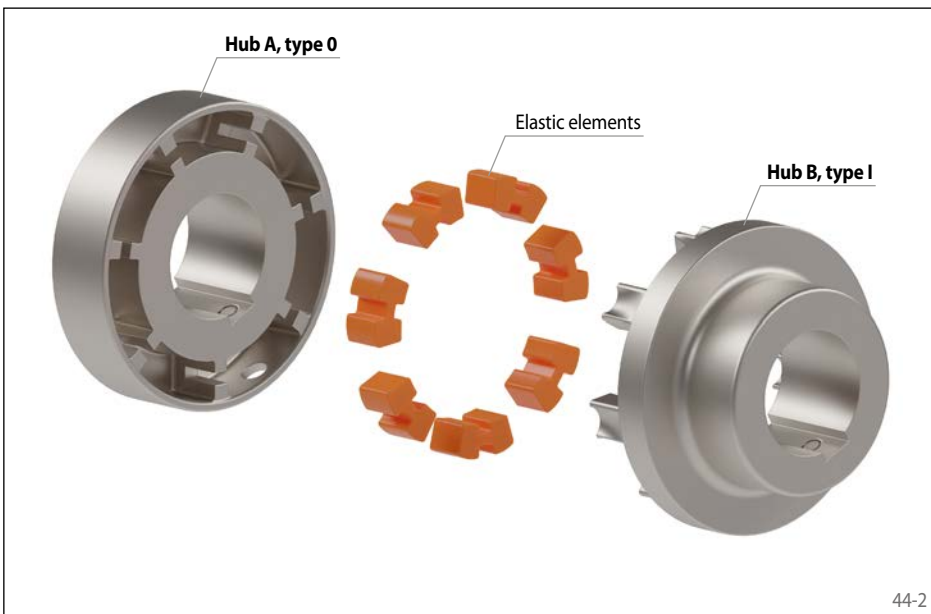

44-2

Order example

	Code
Coupling design	REK
Coupling size	0024
Type	DGO
Material of the hub:	GJL
• Cast iron	
Hub A, type:	0
• 0, elastomer part	
Hub A, design:	FB VA
• finish bored with keyway	
• roughbored	
Bore diameter hub A	020
Hub B, type:	1
• I, jaws	
Hub B, design:	FB VA
• finish bored with keyway	
• roughbored	
Bore diameter hub B	024
Elastic elements:	NB75 PU92 HT00
• NBR 75 Shore-A	
• PU 92 Shore-A	
• HTrans	

REK 0024 DGO-GJL-0FB020-1FB024-NB75



44-3

Jaw Couplings REK ... DGO

elastic for dynamic applications
with enclosed elastic elements

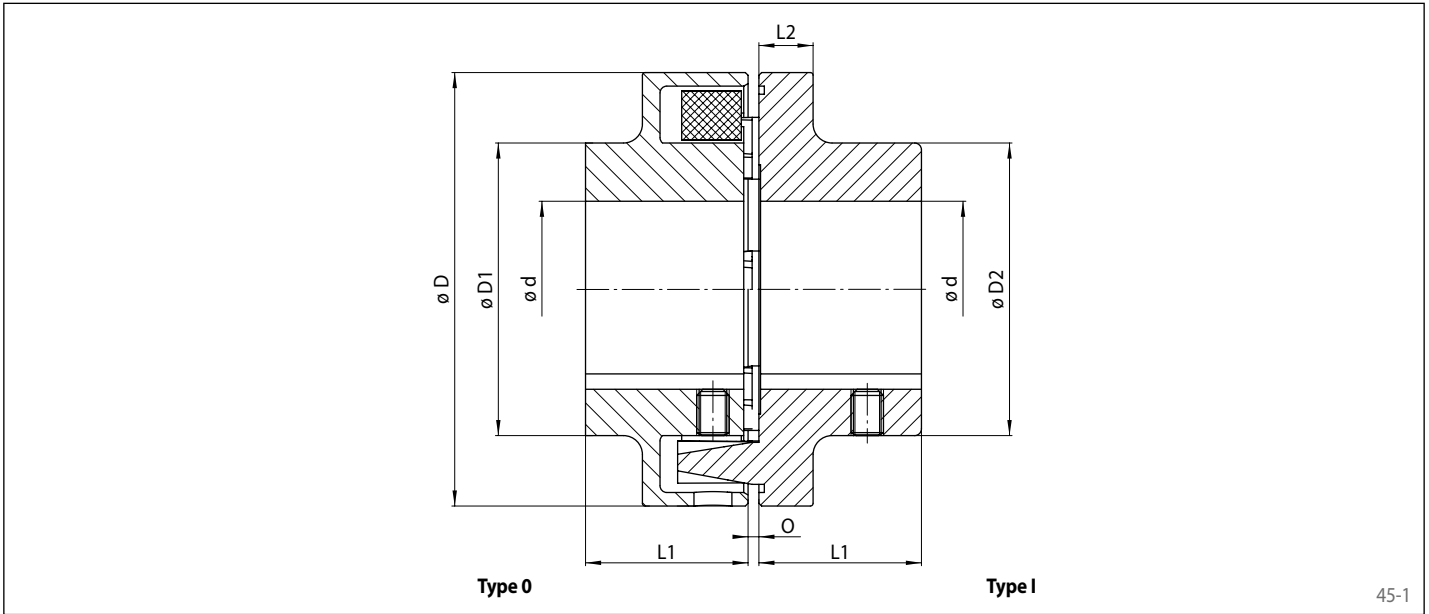

45-1

Coupling size	Max. speed n_{max} min ⁻¹	Moment of inertia with max. bore J_k kgm ²	Pilot bore d^*		Min. bore d^*		Max. bore d^* mm	D mm	D1 mm	D2 mm	L1 mm	L2 mm	O mm	Permissible misalignments			Weight with max. bore kg
			Hub type 0 mm	Hub type I mm	Hub type 0 mm	Hub type I mm								Axial mm	Radial mm	Angular °	
0024	7000	0,0003	8	8	9	9	24	68	-	46	20	8	2-4	±1,5	0,4	1	0,63
0028	6000	0,0012	13	8	14	9	30	80	-	68	30	10	2-4				1,51
0042	5500	0,0027	13	13	14	14	42	95	76	76	35	12	2-4				2,6
0048	5300	0,0055	13	13	14	14	48	110	86	86	40	14	2-4				3,9
0055	5100	0,0107	13	13	14	14	55	125	100	100	50	18	2-4				6,2
0060	4900	0,0140	13	13	14	14	60	140	100	100	55	20	2-4				6,9
0065	4250	0,0250	13	13	14	14	65	160	108	108	60	20	2-6				9,4
0075	3800	0,0450	23	23	24	14	75	180	125	125	70	20	2-6				14,0
0080	3400	0,0800	25	25	26	26	85	200	140	140	80	24	2-6				20,0
0090	3000	0,1350	35	35	36	36	90	225	150	150	90	18	2-6				24,5
0100	2750	0,2300	44	44	45	45	100	250	165	165	100	18	3-8	34,0			

For finish bores, please specify bore diameter hub A and hub B. Tolerance of finish bores H7. Keyways in accordance with DIN 6885, sheet 1. Keyway tolerance JS9.

For vertical installation, please contact RINGSPANN.

See following pages for performance data.

* Bores also available in inch size, see page 73.

Elastic elements

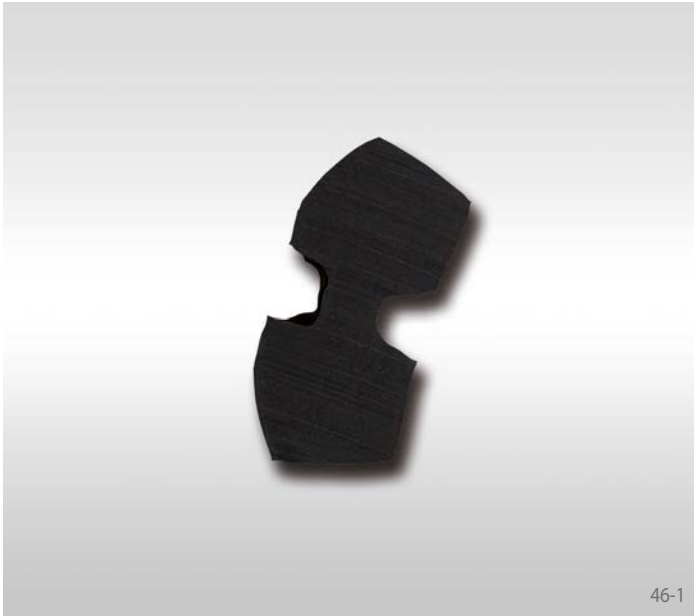

46-1



46-2

Elastic element NBR 75 Shore-A

Material: Nitrile rubber
 Hardness: 75 ±5 Shore-A
 Temperature range: -40 °C to +100 °C
 Colour: black

Elastic element PU 92 Shore-A

Material: Polyurethane
 Hardness: 92 ±5 Shore-A
 Temperature range: -30 °C to +80 °C
 Colour: orange

Coupling size	Nominal torque T_{KN} Nm	Nominal power at 100 min^{-1} P_{K100} kW	Max. torque T_{Kmax} Nm	Alternating torque T_{KW} Nm	Torsional stiffness $C_{T \text{ dyn}}$ Nm/rad x 10^3			Relative damping ψ at 0,5 T_{KN}
					1,0 T_{KN}	0,5 T_{KN}	0,25 T_{KN}	
0024	34	0,36	102	5	3,0	1,1	0,4	2,2
0028	60	0,63	180	9	8,0	2,7	1,1	
0042	100	1,1	300	15	12,0	4,1	1,7	
0048	160	1,7	480	24	19,0	6,8	2,7	
0055	240	2,5	720	36	28,8	10,4	4,2	
0060	360	3,8	1080	54	42,0	15,0	6,0	
0065	560	5,9	1680	84	77,0	28,0	11,0	
0075	880	9,2	2640	132	145,5	58,1	26,9	
0080	1340	14	4020	201	228,0	91,0	42,0	
0090	2000	21	6000	300	341,8	122,0	63,0	
0100	2800	29	8400	420	472,0	169,0	87,0	

Coupling size	Nominal torque T_{KN} Nm	Nominal power at 100 min^{-1} P_{K100} kW	Max. torque T_{Kmax} Nm	Alternating torque T_{KW} Nm	Torsional stiffness $C_{T \text{ dyn}}$ Nm/rad x 10^3			Relative damping ψ at 0,5 T_{KN}
					1,0 T_{KN}	0,5 T_{KN}	0,25 T_{KN}	
0024	51	0,54	153	8	2,0	1,6	1,4	1,7
0028	90	0,95	270	14	5,0	4,0	3,4	
0042	150	1,65	450	23	7,0	6,1	5,2	
0048	240	2,55	720	36	12,0	10,0	8,6	
0055	360	3,75	1080	54	18,3	15,3	13,2	
0060	540	5,70	1620	81	27,0	22,0	19,0	
0065	840	8,85	2520	126	50,0	41,0	35,0	
0075	1320	13,80	3960	198	99,2	71,5	54,0	
0080	2010	21,00	6030	302	155,0	112,0	84,0	
0090	3000	31,50	9000	450	230,4	182,1	134,4	
0100	4200	43,50	12600	630	318,0	252,0	186,0	

Elastic elements



47-1

Elastic element HTrans

Material: Polyurethane
 Hardness: 55 ±2 Shore-D
 Temperature range: -30 °C to +120 °C
 Colour: white

Coupling size	Nominal torque T_{KN} Nm	Nominal power at 100 min^{-1} P_{K100} kW	Max. torque T_{Kmax} Nm	Alternating torque T_{KW} Nm	Torsional stiffness $C_{T \text{ dyn}}$ Nm/rad x 10^3			Relative damping ψ at 0,5 T_{KN}
					1,0 T_{KN}	0,5 T_{KN}	0,25 T_{KN}	
0024	85	0,90	255	13	5	7,8	2,676	0,8
0028	150	1,58	450	23	12	18,9	6,478	
0042	250	2,75	750	38	19	29,0	9,925	
0048	400	4,25	1200	60	31	47,4	16,244	
0055	600	6,25	1800	90	47	49,7	45,314	
0060	900	9,50	2700	135	69	73,0	25,000	
0065	1400	14,75	4200	210	127	133,6	66,560	
0075	2200	23,00	6600	330	248	167,0	130,000	
0080	3350	35,00	10050	503	388	261,0	203,000	
0090	5000	52,50	15000	750	591	472,0	355,000	
0100	7000	72,50	21000	1050	817	652,0	491,000	

Jaw Couplings REK ... DHO

elastic for dynamic applications
with enclosed elastic elements and two piece hub



Features

- Compensation of axial, radial and angular misalignments
- Adsorbs vibrations
- Progressive torsion spring properties due to primarily pressurised elastic elements
- Fail-safe in the event of the failure of the elastic elements
- Easy replacement of elastic elements without disassembly of the coupling halves
- Maintenance free, no lubrication necessary
- Elastic elements can be replaced without moving the drive
- Complies with ATEX 2014/34/EU
- Typical applications: Pump drives, ventilator drives, crane trolleys

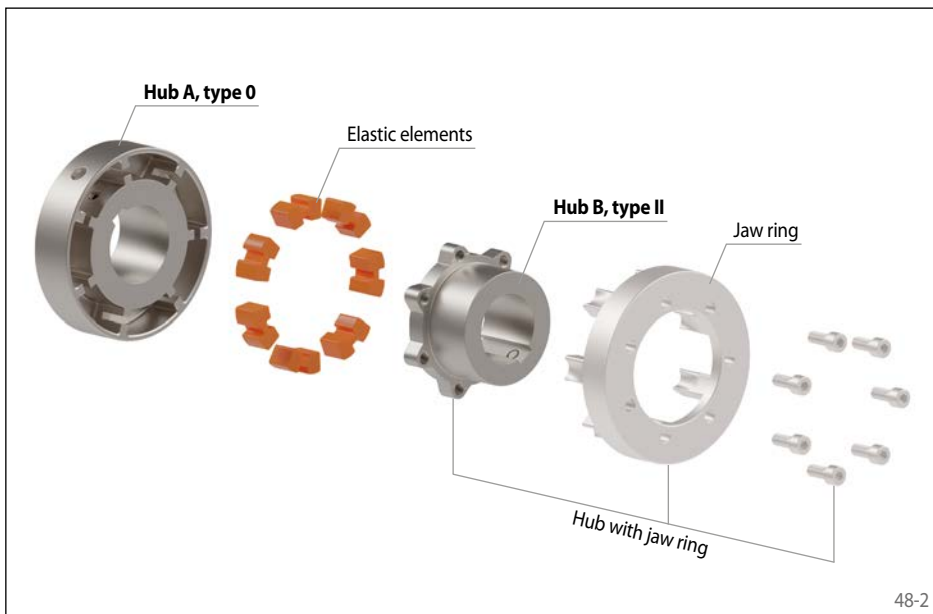

Order example

	Code
Coupling design	REK
Coupling size	0048
Type	DHO
Material of the hub:	GJL
• Cast iron	
Hub A, type:	0
• 0, elastomer part	
Hub A, design:	
• finish bored with keyway	FB
• roughbored	VA
Bore diameter hub A	040
Hub B, type:	2
• II, two-part, hub with jaw ring	
Hub B, design:	
• finish bored with keyway	FB
• roughbored	VA
Bore diameter hub B	038
Elastic elements:	
• NBR 75 Shore-A	NB75
• PU 92 Shore-A	PU92
• HTrans	HT00

REK 0048 DHO-GJL-0FB040-2FB038-NB75



Jaw Couplings REK ... DHO

elastic for dynamic applications
with enclosed elastic elements and two piece hub

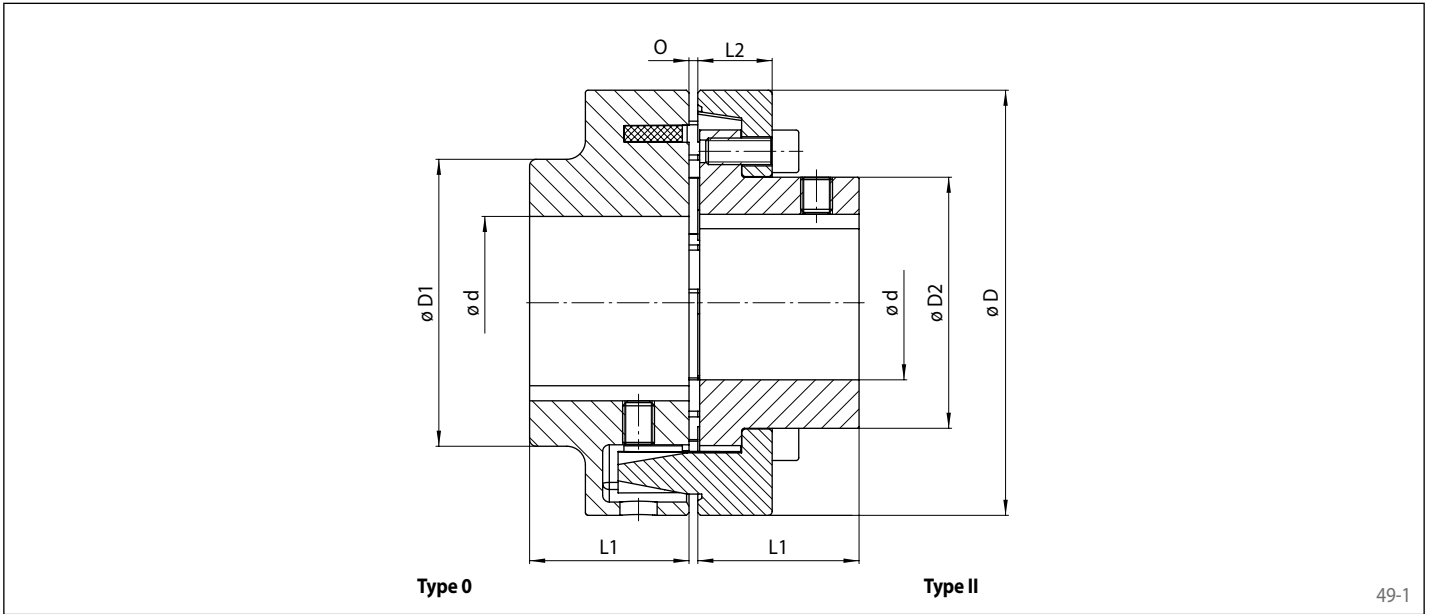

Coupling size	Max. speed n_{max} min ⁻¹	Moment of inertia with max. bore J_k kgm ²	Pilot bore d^* mm	Min. bore d^* mm	Max. bore d^*		D mm	D1 mm	D2 mm	L1 mm	L2 mm	O mm	Permissible misalignments			Weight with max. bore kg
					Hub type 0 mm	Hub type II mm							Axial mm	Radial mm	Angular °	
0048	5300	0,0047	13	14	48	38	110	86	62	40	20	2-4	±1,5	0,4	1	3,5
0055	5100	0,0095	13	14	55	45	125	100	75	50	23	2-4				5,6
0060	4900	0,0150	13	14	60	50	140	100	82	55	28	2-4				7,0
0065	4250	0,0280	13	14	65	58	160	108	95	60	28	2-6				9,8
0075	3800	0,0490	23	24	75	65	180	125	108	70	30	2-6				14,2
0080	3400	0,0850	25	26	85	75	200	140	122	80	32	2-6				19,8
0090	3000	0,1500	35	36	90	85	225	150	138	90	38	2-6				27,0
0100	2750	0,2500	44	45	100	95	250	165	155	100	42	3-8				37,0

For finish bores, please specify bore diameter hub A and hub B. Tolerance of finish bores H7. Keyways in accordance with DIN 6885, sheet 1. Keyway tolerance JS9.
For vertical installation, please contact RINGSPANN.
See following pages for performance data.
* Bores also available in inch size, see page 73.

Elastic elements



50-1



50-2

Elastic element NBR 75 Shore-A

Material: Nitrile rubber
 Hardness: 75 ±5 Shore-A
 Temperature range: -40 °C to +100 °C
 Colour: black

Elastic element PU 92 Shore-A

Material: Polyurethane
 Hardness: 92 ±5 Shore-A
 Temperature range: -30 °C to +80 °C
 Colour: orange

Coupling size	Nominal torque T_{KN} Nm	Nominal power at 100 min^{-1} P_{K100} kW	Max. torque T_{Kmax} Nm	Alternating torque T_{KW} Nm	Torsional stiffness $C_{T \text{ dyn}}$ Nm/rad x 10^3			Relative damping ψ at 0,5 T_{KN}
					1,0 T_{KN}	0,5 T_{KN}	0,25 T_{KN}	
0048	160	1,7	480	24	19,0	6,8	2,7	2,2
0055	240	2,5	720	36	28,8	10,4	4,2	
0060	360	3,8	1080	54	42,0	15,0	6,0	
0065	560	5,9	1680	84	77,0	28,0	11,0	
0075	880	9,2	2640	132	145,5	58,1	26,9	
0080	1340	14	4020	201	228,0	91,0	42,0	
0090	2000	21	6000	300	341,8	122,0	63,0	
0100	2800	29	8400	420	472,0	169,0	87,0	

Coupling size	Nominal torque T_{KN} Nm	Nominal power at 100 min^{-1} P_{K100} kW	Max. torque T_{Kmax} Nm	Alternating torque T_{KW} Nm	Torsional stiffness $C_{T \text{ dyn}}$ Nm/rad x 10^3			Relative damping ψ at 0,5 T_{KN}
					1,0 T_{KN}	0,5 T_{KN}	0,25 T_{KN}	
0048	240	2,55	720	36	12,0	10,0	8,6	1,7
0055	360	3,75	1080	54	18,3	15,3	13,2	
0060	540	5,70	1620	81	27,0	22,0	19,0	
0065	840	8,85	2520	126	50,0	41,0	35,0	
0075	1320	13,80	3960	198	99,2	71,5	54,0	
0080	2010	21,00	6030	302	155,0	112,0	84,0	
0090	3000	31,50	9000	450	230,4	182,1	134,4	
0100	4200	43,50	12600	630	318,0	252,0	186,0	

Elastic elements



51-1

Elastic element HTrans

Material: Polyurethane

Hardness: 55 ±2 Shore-D

Temperature range: -30 °C to +120 °C

Colour: white

Coupling size	Nominal torque T_{KN} Nm	Nominal power at 100 min^{-1} P_{K100} kW	Max. torque T_{Kmax} Nm	Alternating torque T_{KW} Nm	Torsional stiffness $C_{T \text{ dyn}}$ Nm/rad x 10^3			Relative damping ψ at 0,5 T_{KN}
					1,0 T_{KN}	0,5 T_{KN}	0,25 T_{KN}	
0048	400	4,25	1200	60	31	47,4	16,244	0,8
0055	600	6,25	1800	90	47	49,7	45,314	
0060	900	9,50	2700	135	69	73,0	25,000	
0065	1400	14,75	4200	210	127	133,6	66,560	
0075	2200	23,00	6600	330	248	167,0	130,000	
0080	3350	35,00	10050	503	388	261,0	203,000	
0090	5000	52,50	15000	750	591	472,0	355,000	
0100	7000	72,50	21000	1050	817	652,0	491,000	

Jaw Couplings REK ... DGZ

elastic for dynamic applications
with enclosed elastic elements and spacer



Features

- Compensation of axial, radial and angular misalignments
- Adsorbs vibrations
- Progressive torsion spring properties due to primarily pressurised elastic elements
- Fail-safe in the event of the failure of the elastic elements
- Easy replacement of elastic elements without disassembly of the coupling halves
- Easy separation of the drive train through disassembly of the coupling spacer
- Maintenance free, no lubrication necessary
- Complies with ATEX 2014/34/EU
- Typical applications: Pump drives, ventilator drives, crane trolleys

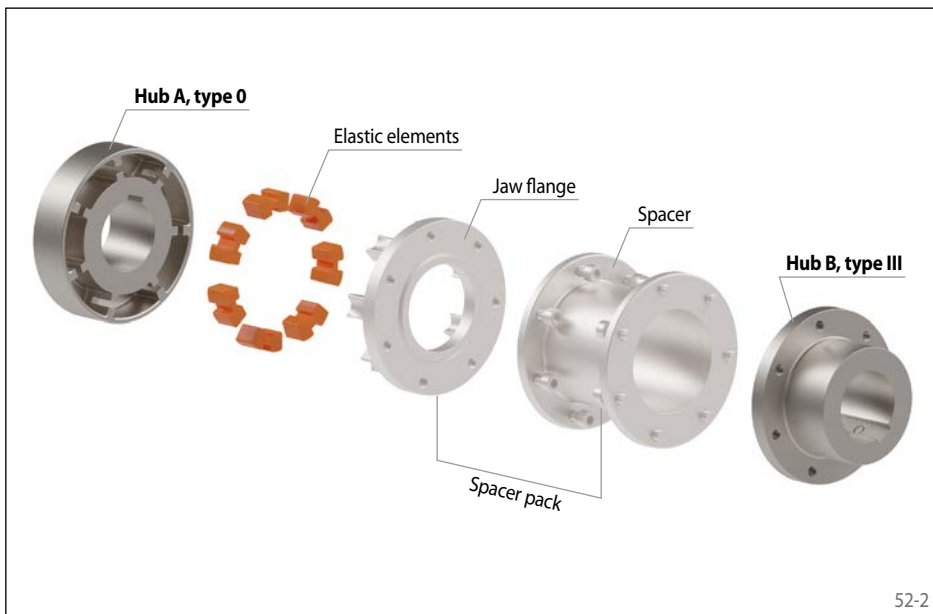

Order example

Order example	Code
Coupling design	REK
Coupling size	0028
Type	DGZ
Material of the hub:	GJL
• Cast iron	
Hub A, type:	0
• 0, elastomer part	
Hub A, design:	FB VA
• finish bored with keyway	
• roughbored	
Bore diameter hub A	025
Hub B, type:	3
• III, flange part	
Hub B, design:	FB VA
• finish bored with keyway	
• roughbored	
Bore diameter hub B	032
Elastic elements:	NB75 PU92 HT00
• NBR 75 Shore-A	
• PU 92 Shore-A	
• HTrans	
DBSE L3	0140



Jaw Couplings REK ... DGZ

elastic for dynamic applications
with enclosed elastic elements and spacer

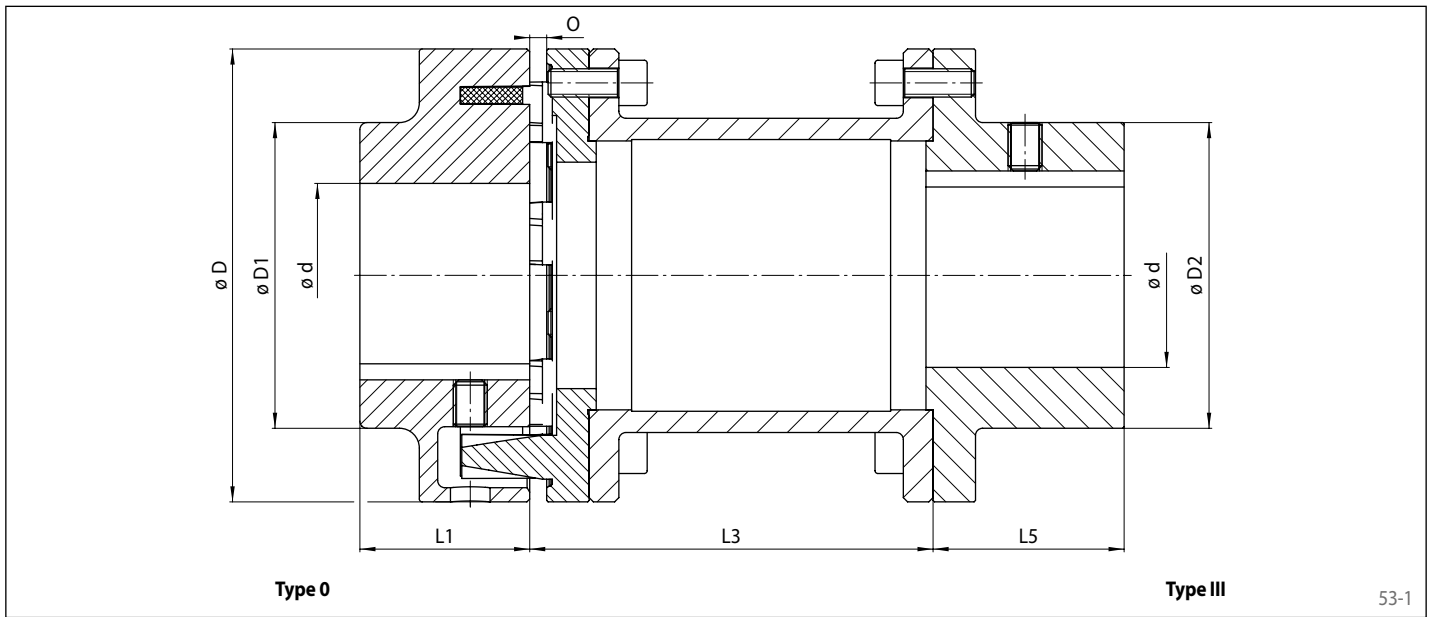

53-1

Coupling size	Max. speed n_{max} min ⁻¹	Moment of inertia with max. bore J_k kgm ²	Pilot bore d^*		Min. bore d^*		Max. bore d^* mm	D mm	D1 mm	D2 mm	L1 mm	L3 mm	L5 mm	O mm	Permissible misalignments			Weight with max. bore kg
			Hub type 0 mm	Hub type III mm	Hub type 0 mm	Hub type III mm									Axial mm	Radial mm	Angular °	
0028	6000	0,0014 0,0015	13	8	14	9	30/32	80	-	55	30	100 140	45	5	±1,5	0,4	1	2,8 2,9
0042	5500	0,0028 0,0031	13	13	14	14	42	95	76	70	35	100 140	45	5				3,9 4,2
0048	5300	0,0056 0,0060 0,0064	13	13	14	14	48	110	86	80	40	100 140 180	50	5				5,8 6,2 6,6
0055	5100	0,0099 0,0100 0,0110	13	13	14	14	55	125	100	90	50	100 140 180	50	5				8,2 8,7 9,2
0060	4900	0,0190 0,0200	13	13	14	14	60	140	100	100	55	140 180	65	5				11,8 12,3
0065	4250	0,0320 0,0340	13	13	14	14	65	160	108	108	60	140 180	70	6				15,2 16,0
0075	3800	0,0540 0,0580	23	23	24	24	75	180	125	125	70	140 180	80	6				21,0 21,9
0080	3400	0,1000 0,1050 0,1100	25	25	26	26	85	200	140	140	80	180 200 250	90	6				30,3 30,9 32,1
0090	3000	0,1600 0,1700 0,1800	35	35	36	36	90	225	150	150	90	180 200 250	100	6				39,0 39,7 41,5
0100	2750	0,2800 0,3000	44	44	45	45	100	250	165	165	100	200 250	110	8				54,7 56,5

For finish bores, please specify bore diameter hub A and hub B. Tolerance of finish bores H7. Keyways in accordance with DIN 6885, sheet 1. Keyway tolerance JS9.

Upon request: Hub type III in extended design; Spacers for varying DBSEs L3

For vertical installation, please contact RINGSPANN.

See following pages for performance data.
* Bores also available in inch size, see page 73.

Elastic elements

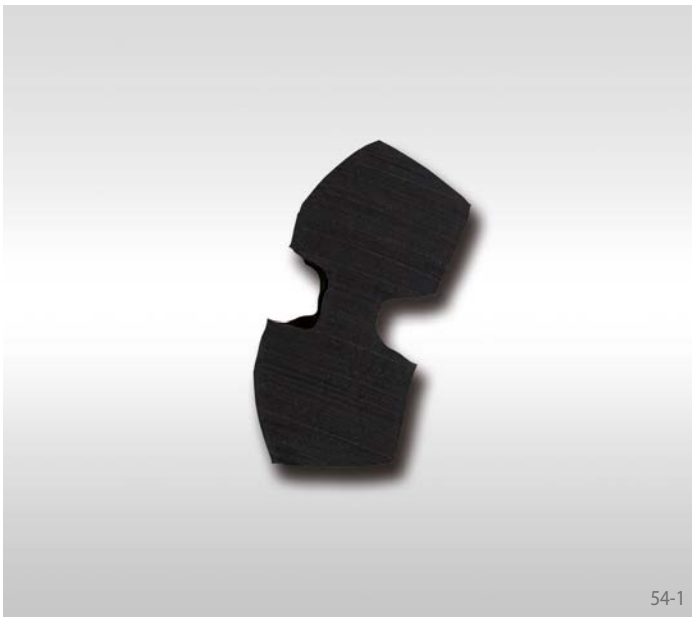

54-1

Elastic element NBR 75 Shore-A

Material: Nitrile rubber
 Hardness: 75 ±5 Shore-A
 Temperature range: -40 °C to +100 °C
 Colour: black



54-2

Elastic element PU 92 Shore-A

Material: Polyurethane
 Hardness: 92 ±5 Shore-A
 Temperature range: -30 °C to +80 °C
 Colour: orange

Coupling size	Nominal torque T_{KN} Nm	Nominal power at 100 min^{-1} P_{K100} kW	Max. torque $T_{K \max}$ Nm	Alternating torque T_{KW} Nm	Torsional stiffness $C_{T \text{ dyn}}$ Nm/rad x 10^3			Relative damping ψ at 0,5 T_{KN}
					1,0 T_{KN}	0,5 T_{KN}	0,25 T_{KN}	
0028	60	0,63	180	9	8,0	2,7	1,1	2,2
0042	100	1,1	300	15	12,0	4,1	1,7	
0048	160	1,7	480	24	19,0	6,8	2,7	
0055	240	2,5	720	36	28,8	10,4	4,2	
0060	360	3,8	1080	54	42,0	15,0	6,0	
0065	560	5,9	1680	84	77,0	28,0	11,0	
0075	880	9,2	2640	132	145,5	58,1	26,9	
0080	1340	14	4020	201	228,0	91,0	42,0	
0090	2000	21	6000	300	341,8	122,0	63,0	
0100	2800	29	8400	420	472,0	169,0	87,0	

Coupling size	Nominal torque T_{KN} Nm	Nominal power at 100 min^{-1} P_{K100} kW	Max. torque $T_{K \max}$ Nm	Alternating torque T_{KW} Nm	Torsional stiffness $C_{T \text{ dyn}}$ Nm/rad x 10^3			Relative damping ψ at 0,5 T_{KN}
					1,0 T_{KN}	0,5 T_{KN}	0,25 T_{KN}	
0028	90	0,95	270	14	5,0	4,0	3,4	1,7
0042	150	1,65	450	23	7,0	6,1	5,2	
0048	240	2,55	720	36	12,0	10,0	8,6	
0055	360	3,75	1080	54	18,3	15,3	13,2	
0060	540	5,70	1620	81	27,0	22,0	19,0	
0065	840	8,85	2520	126	50,0	41,0	35,0	
0075	1320	13,80	3960	198	99,2	71,5	54,0	
0080	2010	21,00	6030	302	155,0	112,0	84,0	
0090	3000	31,50	9000	450	230,4	182,1	134,4	
0100	4200	43,50	12600	630	318,0	252,0	186,0	

Elastic elements



55-1

Elastic element HTrans

Material: Polyurethane

Hardness: 55 ±2 Shore-D

Temperature range: -30 °C to +120 °C

Colour: white

Coupling size	Nominal torque T_{KN} Nm	Nominal power at 100 min^{-1} P_{K100} kW	Max. torque T_{Kmax} Nm	Alternating torque T_{KW} Nm	Torsional stiffness $C_{T \text{ dyn}}$ Nm/rad x 10^3			Relative damping ψ at 0,5 T_{KN}
					1,0 T_{KN}	0,5 T_{KN}	0,25 T_{KN}	
0028	150	1,58	450	23	12	18,9	6,478	0,8
0042	250	2,75	750	38	19	29,0	9,925	
0048	400	4,25	1200	60	31	47,4	16,244	
0055	600	6,25	1800	90	47	49,7	45,314	
0060	900	9,50	2700	135	69	73,0	25,000	
0065	1400	14,75	4200	210	127	133,6	66,560	
0075	2200	23,00	6600	330	248	167,0	130,000	
0080	3350	35,00	10050	503	388	261,0	203,000	
0090	5000	52,50	15000	750	591	472,0	355,000	
0100	7000	72,50	21000	1050	817	652,0	491,000	

Jaw Couplings REK ... DCO

elastic for dynamic applications
with curved jaws



Features

- Compensation of axial, radial and angular misalignments
- Adsorbs vibrations
- Symmetrical design allows for high running speeds without additional balancing
- Fail-safe in the event of the failure of the spider
- Maintenance free, no lubrication necessary
- Complies with ATEX 2014/34/EU
- Typical applications: Pump drives, ventilator drives, crane trolleys, machine tools, conveyor belts

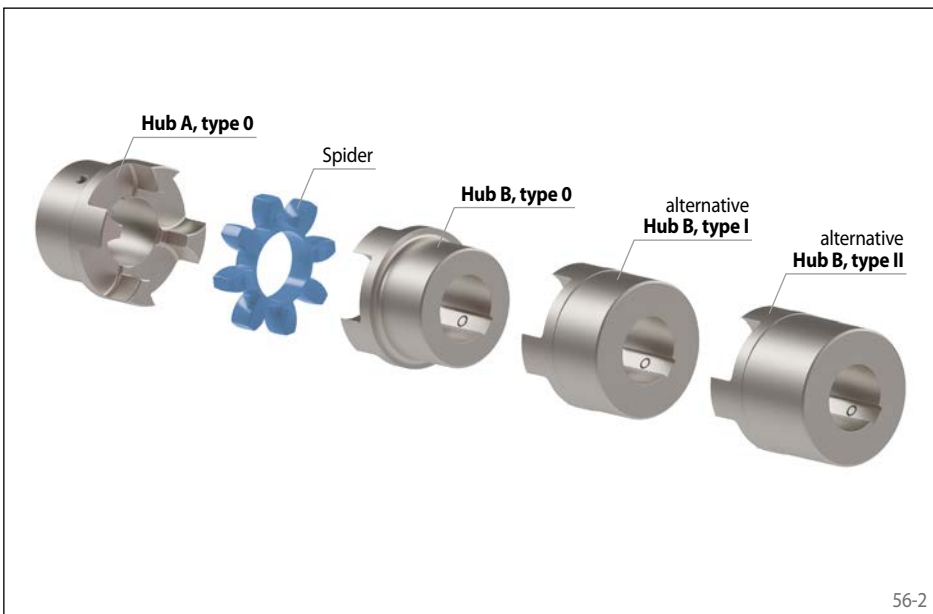

Order example

Order example	Code
Coupling design	REK
Coupling size	0019
Type	DCO
Material of the hub*:	
• Steel	STA
• Cast iron	GJL
• Aluminum	ALU
Hub A, type:	
• 0, standard	0
• I, increased max. bore	1
• II, extended, increased max. bore (from size 0038)	2
Hub A, design:	
• finish bored with keyway	FB
• roughbored	VA
Bore diameter hub A	019
Hub B, type:	
• 0, standard	0
• I, increased max. bore	1
• II, extended, increased max. bore (from size 0038)	2
Hub B, design:	
• finish bored with keyway	FB
• roughbored	VA
Bore diameter hub B	019
Spiders:	
• PU 92 Shore-A	PU92
• PU 95 Shore-A	PU95
• TU 92 Shore-A	TU92
• TU 98 Shore-A	TU98
• TU 65 Shore-D	TU65

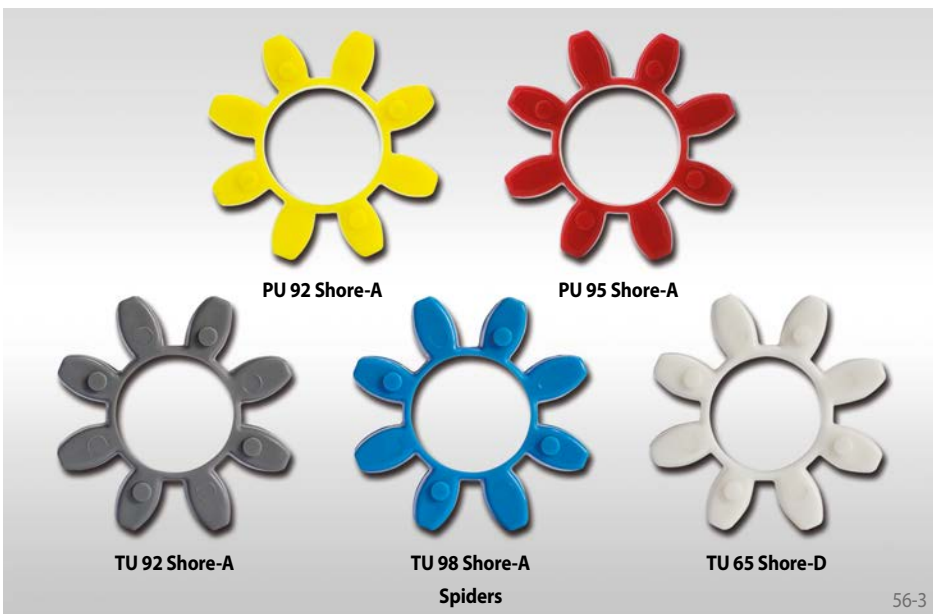

REK 0019 DCO-ALU-0FB019-0FB019-PU92

* See opposite table for availability

Jaw Couplings REK ... DCO

elastic for dynamic applications
with curved jaws

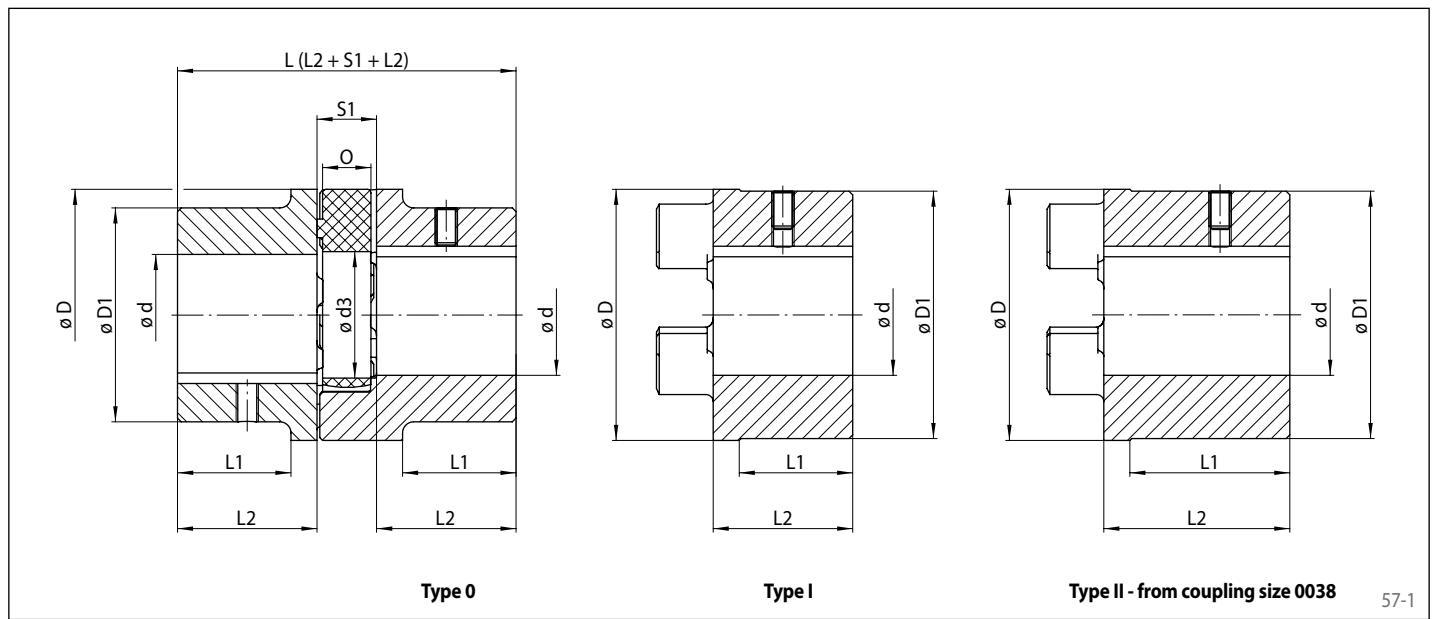

Coupling size	Material of hub			Max. speed n_{max}			Permissible misalignments		
	Steel	Cast iron	Aluminum	Steel	Cast iron	Aluminum	Axial	Radial	Angulaire
	STA	GJL	ALU	min^{-1}	min^{-1}	min^{-1}	mm	mm	°
0019	x	-	x	18650	-	19000	1,6	0,15	0,8
0024	x	-	x	13650	-	14000	1,8	0,20	0,8
0028	x	-	x	11600	-	11800	2,0	0,20	0,8
0038	x	x	-	9500	7100	-	2,2	0,25	0,9
0042	x	x	-	8000	6000	-	2,3	0,30	0,9
0048	x	x	-	7200	5600	-	3,0	0,35	1,0
0055	x	x	-	6350	4750	-	3,0	0,35	1,0
0065	x	x	-	5650	4250	-	3,5	0,40	1,0
0075	x	x	-	4750	3550	-	3,5	0,45	1,1
0090	x	x	-	3800	2800	-	4,5	0,50	1,1

Coupling size	Pilot bore d^*	Min. bore d^*			Max. bore d^*						$d3$	D	D1		L1				L2		O	S1
		Hub type			Hub type								Hub type		Hub type				Hub type			
		0	I	II	0		I		II				0	I/II	0/I		II		0/I	II		
mm	mm	mm	mm	mm	mm	mm	mm	mm	mm	mm	mm	mm	mm	mm	mm	mm	mm	mm	mm	mm	mm	mm
0019	-	6	19	-	21	19	25	24	-	-	18	41	32	41	20	20	-	-	25	-	12	16
0024	-	9	22	-	26	24	35	28	-	-	27	56	40	56	24	24	-	-	30	-	14	18
0028	-	10	28	-	32	28	40	38	-	-	30	66	48	66	28	28	-	-	35	-	15	20
0038	10	12	38	12	48	40	48	48	48	48	38	80	66	78	27	37	52	62	45	70	18	24
0042	12	14	42	14	55	45	55	55	55	55	46	95	75	94	28	40	53	65	50	75	20	26
0048	13	15	48	15	62	52	62	62	62	62	51	105	85	104	32	45	56	69	56	80	21	28
0055	18	20	55	20	74	60	74	74	74	74	60	120	98	118	37	52	62	77	65	90	22	30
0065	20	22	65	22	80	70	80	80	80	80	68	135	115	133	47	61	72	86	75	100	26	35
0075	28	30	75	30	95	80	95	95	95	95	80	160	135	158	53	69	78	84	85	110	30	40
0090	38	40	90	40	110	97	110	110	110	110	100	200	160	198	62	81	87	106	100	125	34	45

For finish bores, please specify bore diameter hub A and hub B. Tolerance of finish bores H7. Keyways in accordance with DIN 6885, sheet 1. Keyway tolerance JS9. See following pages for weights, moments of inertia and performance data.
* Bores also available in inch size, see page 73.

Weights and moments of inertia

Weights in kg with max. bore diameter

Coupling size	Steel			Cast iron			Aluminum		
	Hub type			Hub type			Hub type		
	0	I	II	0	I	II	0	I	II
0019	0,14	0,18	0,26	-	-	-	0,05	0,07	-
0024	0,29	0,37	0,61	-	-	-	0,12	0,16	-
0028	0,45	0,64	1,07	-	-	-	0,19	0,25	-
0038	1,00	1,27	1,90	1,0	1,2	1,8	-	-	-
0042	1,81	1,84	2,76	1,6	1,8	2,3	-	-	-
0048	2,43	2,74	3,80	2,2	2,6	3,1	-	-	-
0055	3,70	3,93	5,23	3,3	3,7	5,1	-	-	-
0065	4,50	5,85	7,58	5,0	5,7	7,3	-	-	-
0075	7,18	9,06	11,50	7,9	9,0	10,5	-	-	-
0090	12,5	17,00	21,15	13,6	18,2	22,3	-	-	-

Moments of inertia [$10^{-3} \times \text{kgm}^2$] with max. bore diameter

Coupling size	Steel			Cast iron			Aluminum		
	Hub type			Hub type			Hub type		
	0	I	II	0	I	II	0	I	II
0019	0,04	0,05	0,07	-	-	-	0,011	0,021	-
0024	0,16	0,21	0,35	-	-	-	0,045	0,085	-
0028	0,34	0,48	0,80	-	-	-	0,100	0,210	-
0038	0,98	1,40	0,03	0,93	1,23	1,86	-	-	-
0042	2,50	2,55	3,82	2,05	2,95	4,27	-	-	-
0048	4,10	5,20	7,21	3,10	4,80	6,70	-	-	-
0055	8,20	10,00	10,00	6,15	8,65	11,85	-	-	-
0065	10,00	20,00	30,00	12,25	13,90	18,15	-	-	-
0075	30,00	40,00	50,00	27,00	30,70	35,75	-	-	-
0090	70,00	120,00	150,00	69,00	91,50	112,50	-	-	-

Spiders

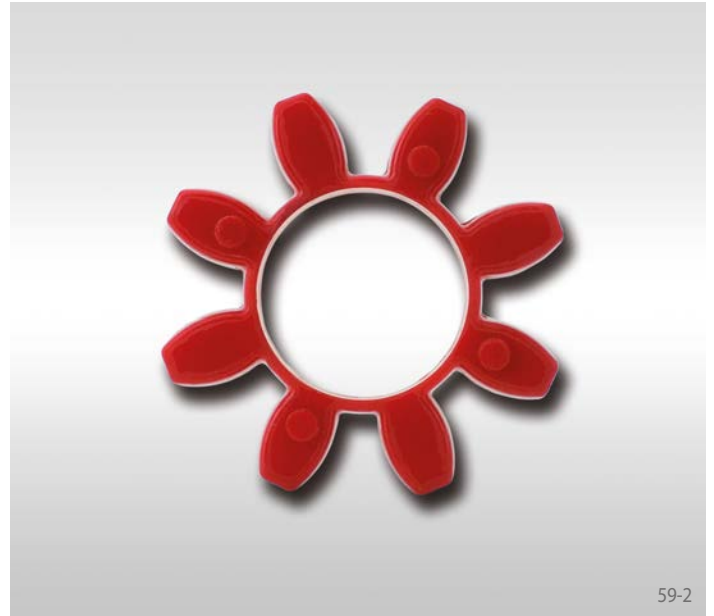
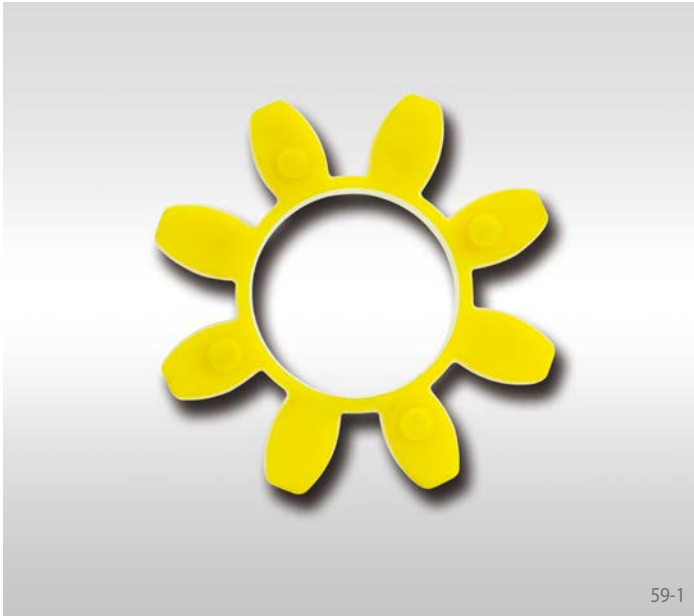

Spider PU 92 Shore-A

Material: Polyurethane
 Hardness: 92 ±2 Shore-A
 Temperature range: -30 °C to +80 °C
 Colour: yellow

Spider PU 95 Shore-A

Material: Polyurethane
 Hardness: 95 ±2 Shore-A
 Temperature range: -30 °C to +90 °C
 Colour: red

Coupling size	Nominal torque T_{KN} Nm	Nominal power at 100 min^{-1} P_{K100} kW	Max. torque $T_{K \max}$ Nm	Alternating torque T_{KW} Nm	Torsional stiffness $C_{T \text{ dyn}}$ Nm/rad x 10^3			Relative damping ψ at 0,5 T_{KN}
					1,0 T_{KN}	0,5 T_{KN}	0,25 T_{KN}	
0019	9,6	0,1	19	2,5	0,5	0,4	0,2	0,9
0024	33	0,3	69	8,9	2,0	1,3	0,9	
0028	91	1,0	186	24	5,1	3,4	2,3	
0038	181	1,9	372	48	10,2	6,7	4,6	
0042	253	2,6	510	67	14,4	9,4	6,5	
0048	296	3,1	600	79	16,6	10,9	7,5	
0055	392	4,1	800	105	22,9	15,0	10,4	
0065	590	6,3	1220	160	26,0	19,3	13,9	
0075	1220	12,8	2500	326	54,4	40,4	29,0	
0090	2290	24,0	4700	610	86,7	64,0	47,0	

Coupling size	Nominal torque T_{KN} Nm	Nominal power at 100 min^{-1} P_{K100} kW	Max. torque $T_{K \max}$ Nm	Alternating torque T_{KW} Nm	Torsional stiffness $C_{T \text{ dyn}}$ Nm/rad x 10^3			Relative damping ψ at 0,5 T_{KN}
					1,0 T_{KN}	0,5 T_{KN}	0,25 T_{KN}	
0019	16	0,2	32	4,2	1,3	0,9	0,6	0,9
0024	57	0,6	114	15,2	4,8	3,2	2,1	
0028	153	1,6	304	40,0	12,1	8,2	5,4	
0038	310	3,2	610	81,0	24,0	16,2	10,6	
0042	430	4,5	850	111	33,9	22,9	12,3	
0048	500	5,2	990	130	39,2	26,4	16,9	
0055	650	6,8	1300	169	53,9	36,4	25,3	
0065	890	9,4	1780	232	69,3	47,6	33,3	
0075	1830	19,2	3640	474	84,6	58,9	41,4	
0090	3430	36,0	6800	889	150,9	118,5	85,5	

Spiders



60-1

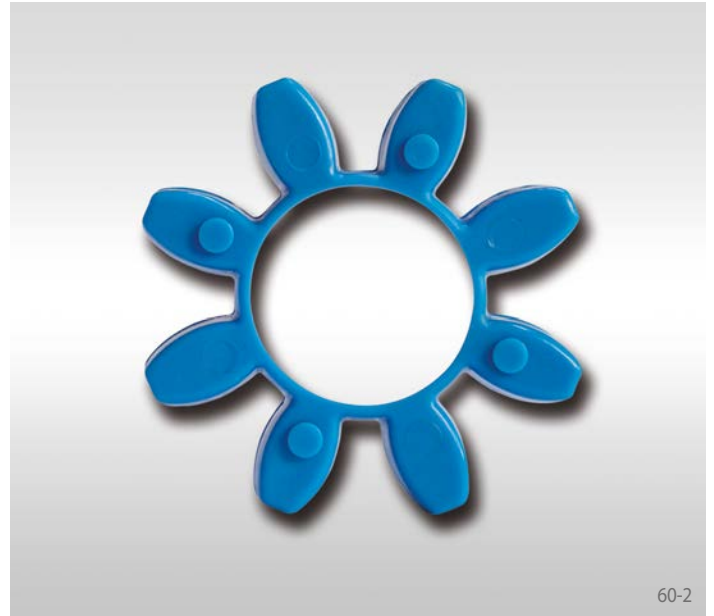

60-2

Spider TU 92 Shore-A

Material: Polyurethane
 Hardness: 92 ±2 Shore-A
 Temperature range: -30 °C to +120 °C
 Colour: grey

Spider TU 98 Shore-A

Material: Polyurethane
 Hardness: 98 ±2 Shore-A
 Temperature range: -30 °C to +120 °C
 Colour: blue

Coupling size	Nominal torque T_{KN} Nm	Nominal power at 100 min^{-1} P_{K100} kW	Max. torque $T_{K \max}$ Nm	Alternating torque T_{KW} Nm	Torsional stiffness $C_{T \text{ dyn}}$ Nm/rad x 10^3			Relative damping ψ at 0,5 T_{KN}
					1,0 T_{KN}	0,5 T_{KN}	0,25 T_{KN}	
0019	9,6	0,1	19	2,5	0,52	0,34	0,24	0,9
0024	33	0,3	69	8,9	1,96	1,29	0,92	
0028	91	1	186	24	4,95	3,24	2,32	
0038	181	1,9	372	48	9,80	6,42	4,59	
0042	253	2,6	510	67	15,41	10,37	7,39	
0048	296	3,1	600	79	17,82	11,99	8,55	
0055	392	4,1	800	105	24,51	16,50	11,76	
0065	590	6,2	1220	160	40,37	27,75	19,75	
0075	1220	12,8	2500	326	84,55	58,11	41,36	
0090	2290	24	4700	610	158,74	109,11	77,65	

Coupling size	Nominal torque T_{KN} Nm	Nominal power at 100 min^{-1} P_{K100} kW	Max. torque $T_{K \max}$ Nm	Alternating torque T_{KW} Nm	Torsional stiffness $C_{T \text{ dyn}}$ Nm/rad x 10^3			Relative damping ψ at 0,5 T_{KN}
					1,0 T_{KN}	0,5 T_{KN}	0,25 T_{KN}	
0019	18	0,2	36	4,50	1,59	1,16	0,80	0,9
0024	62	0,6	124	15,50	6,24	4,53	3,14	
0028	167	1,7	334	41,75	15,32	11,12	7,71	
0038	332	3,5	664	83,00	30,89	22,41	15,54	
0042	477	5,0	954	119,25	45,49	33,16	22,98	
0048	525	5,5	1050	131,25	52,25	38,09	26,39	
0055	694	7,3	1388	173,50	70,55	51,44	35,64	
0065	973	10,2	1946	243,25	100,65	73,71	51,04	
0075	1980	20,7	3960	495,00	209,61	153,50	106,29	
0090	3523	36,9	7046	880,75	413,38	272,95	134,19	

Spiders



61-1

Spider TU 65 Shore-D

Material: Polyurethane

Hardness: 65 ±2 Shore-D

Temperature range: -30 °C to +120 °C

Colour: white

Coupling size	Nominal torque T_{KN} Nm	Nominal power at 100 min^{-1} P_{K100} kW	Max. torque T_{Kmax} Nm	Alternating torque T_{KW} Nm	Torsional stiffness $C_{T \text{ dyn}}$ Nm/rad x 10^3			Relative damping ψ at 0,5 T_{KN}
					1,0 T_{KN}	0,5 T_{KN}	0,25 T_{KN}	
0019	21	0,2	42	5,25	1,99	1,37	0,98	1,0
0024	76	0,8	152	19,00	7,92	5,45	3,91	
0028	198	2,1	396	49,50	18,88	12,98	9,31	
0038	402	4,2	804	100,50	38,14	22,41	15,54	
0042	560	5,9	1120	140,00	60,36	45,49	29,75	
0048	667	7,0	1334	166,75	71,04	53,54	35,01	
0055	834	8,7	1668	208,50	92,27	69,54	45,47	
0065	1155	12,1	2310	288,75	141,08	102,45	59,79	
0075	2380	24,9	4760	595,00	294,43	213,82	124,77	
0090	4514	47,3	9028	1128,50	550,50	338,37	183,26	

Selection of IEC standard motors

Frame size	A.C. motor 50 Hz		Motor power n = 3 000 min ⁻¹ 2 pole		REK ... DCO	Motor power n = 1 500 min ⁻¹ 4 pole		REK ... DCO	Motor power n = 1 000 min ⁻¹ 6 pole		REK ... DCO	Motor power n = 750 min ⁻¹ 8 pole		REK ... DCO
	Shaft end d x l 2 pole	4, 6, 8 pole	Power P _{AN}	Torque T _{AN}	Coupling size	Power P _{AN}	Torque T _{AN}	Coupling size	Power P _{AN}	Torque T _{AN}	Coupling size	Power P _{AN}	Torque T _{AN}	Coupling size
56	9 x 20		0,09 0,12	0,32 0,41	0019 Hub type 0	0,06 0,09	0,43 0,64	0019 Hub type 0	0,037 0,045	0,43 0,52	0019 Hub type 0	-	-	-
63	11 x 23		0,18 0,25	0,62 0,86		0,12 0,18	0,88 1,3		0,06 0,09	0,7 1,1		-	-	-
71	14 x 30		0,37 0,55	1,3 1,9		0,25 0,37	1,8 2,5		0,18 0,25	2 2,8		0,09 0,12	1,4 1,8	0019 Hub type 0
80	19 x 40		0,75 1,1	2,5 3,7		0,55 0,75	3,7 5,1		0,37 0,55	3,9 5,8		0,18 0,25	2,5 3,5	0019 Hub type 0
90S	24 x 50		1,5	5	0019 Hub type I	1,1	7,5	0019 Hub type I	0,75	8	0019 Hub type I	0,37	5,3	0019 Hub type I
90L			2,2	7,4		1,5	10		1,1	12		0,55	7,9	
100L	28 x 60		3	9,8	0024 Hub type I	2,2 3	15 20	0024 Hub type I	1,5	15	0024 Hub type I	0,75 1,1	11 16	0024 Hub type I
112M			4	13		4	27		2,2	22		1,5	21	
132S	38 x 80		5,5 7,5	18 25	0028 Hub type I	5,5	36	0028 Hub type I	3	30	0028 Hub type I	2,2	30	0028 Hub type I
132M			-	-		7,5	49		4 5,5	40 55		3	40	
160M	42 x 110		11 15	36 49	0038 Hub type I (II)	11	72	0038 Hub type I (II)	7,5	75	0038 Hub type I (II)	4 5,5	54 74	0038 Hub type I (II)
160L			18,5	60		15	98		11	109		7,5	100	
180M	48 x 110		22	71	0042 Hub type I (II)	18,5	121	0042 Hub type I (II)	-	-	0042 Hub type I (II)	-	-	0042 Hub type I (II)
180L			-	-		22	144		15	148		11	145	
200L	55 x 110		30 37	97 120	0042 Hub type I (II)	30	196	0042 Hub type I (II)	18,5 22	181 215	0042 Hub type I (II)	15	198	0042 Hub type I (II)
225S	55 x 110	60 x 140	-	-		37	240		0048 Hub type I (II)	-		-	0048 Hub type I (II)	
225M			45	140	45	292	30	293		22	290			
250M	60 x 140	65 x 140	55	177	0048 Hub type I (II)	55	356	0055 Hub type I (II)	37	361	0055 Hub type I (II)	30	392	0055 Hub type I (II)
280S	75 x 140		75	241	0055 Hub type I (II)	75	484	0065 Hub type I (II)	45	438	0065 Hub type I (II)	37	483	0065 Hub type I (II)
280M			90	289		90	581		55	535		45	587	
315S	65 x 140		110	353	0065 Hub type I (II)	110	707	0075 Hub type 0	75	727	0075 Hub type 0	55	712	0075 Hub type 0
315M			132	423		132	849		90	873		75	971	
315L	80 x 170		160 200	513 641	0075 Hub type I (II)	160 200	1030 1290	0090 Hub type 0	110 132	1070 1280	0090 Hub type 0	90 110	1170 1420	0090 Hub type 0
355L			75 x 140	95 x 170		250 315	802 1010		250 315	1600 2020		160 200 250	1550 1930 2410	
400	80 x 170	110 x 210	355 400	1140 1280	0090 Hub type I (II)	355 400	2280 2570	0090 Hub type I (II)	315	3040	0090 Hub type I (II)	250	3220	0090 Hub type I (II)

During selection, the nominal torque of the coupling at +30 °C was factored in with a start-up factor S₂ of 1 and a co-efficient of impact S_A/S_L of 1. Detailed selection in accordance with the technical information on page 70 et seq.

Standard bores

Coupling size	Material	Hub type	Bore d							
			mm	mm	mm	mm	mm	mm	mm	mm
0019	STA	0	9	11	14	15	18	19	-	-
		I	20	24	-	-	-	-	-	-
	ALU	0	9	11	14	15	18	19	-	-
		I	20	24	-	-	-	-	-	-
0024	STA	0	11	14	15	18	19	20	22	24
		I	28	-	-	-	-	-	-	-
	ALU	0	11	14	15	18	19	20	22	24
		I	28	-	-	-	-	-	-	-
0028	STA	0	14	15	18	19	20	22	24	-
		I	28	32	38	-	-	-	-	-
	ALU	0	14	15	18	19	20	22	24	-
		I	28	32	38	-	-	-	-	-
0038	STA	0	20	24	28	32	38	-	-	-
		I	42	48	-	-	-	-	-	-
		II	32	38	42	48	-	-	-	-
	GJL	0	18	19	20	22	24	28	32	38
		I	42	48	-	-	-	-	-	-
		II	32	38	42	48	-	-	-	-
0042	STA	0	28	32	38	40	42	-	-	-
		I	48	55	-	-	-	-	-	-
		II	38	42	48	55	-	-	-	-
	GJL	0	20	22	24	28	32	38	40	42
		I	48	55	-	-	-	-	-	-
		II	38	42	48	55	-	-	-	-
0048	STA	0	32	38	42	48	-	-	-	-
		I	55	60	-	-	-	-	-	-
		II	42	48	55	60	-	-	-	-
	GJL	0	24	28	32	38	42	48	-	-
		I	55	60	-	-	-	-	-	-
		II	42	48	55	60	-	-	-	-
0055	STA	0	32	38	42	48	55	-	-	-
		I	60	65	-	-	-	-	-	-
		II	48	55	60	65	-	-	-	-
	GJL	0	28	32	38	42	48	55	-	-
		I	60	65	-	-	-	-	-	-
		II	48	55	60	65	-	-	-	-
0065	STA	0	48	55	60	65	-	-	-	-
		I	75	80	-	-	-	-	-	-
		II	60	65	75	80	-	-	-	-
	GJL	0	32	38	42	48	55	60	65	-
		I	75	80	-	-	-	-	-	-
		II	60	65	75	80	-	-	-	-
0075	STA	0	48	55	60	65	75	-	-	-
		I	80	85	-	-	-	-	-	-
		II	65	75	80	85	-	-	-	-
	GJL	0	42	48	55	60	65	75	-	-
		I	80	-	-	-	-	-	-	-
		II	60	65	75	80	-	-	-	-
0090	STA	0	65	75	80	90	-	-	-	-
		I	100	110	-	-	-	-	-	-
		II	80	90	100	110	-	-	-	-
	GJL	0	48	55	60	65	75	80	90	-
		I	95	110	-	-	-	-	-	-
		II	80	90	95	110	-	-	-	-

Jaw Couplings REK ... DCS

elastic for dynamic applications
with curved jaws and brake disc

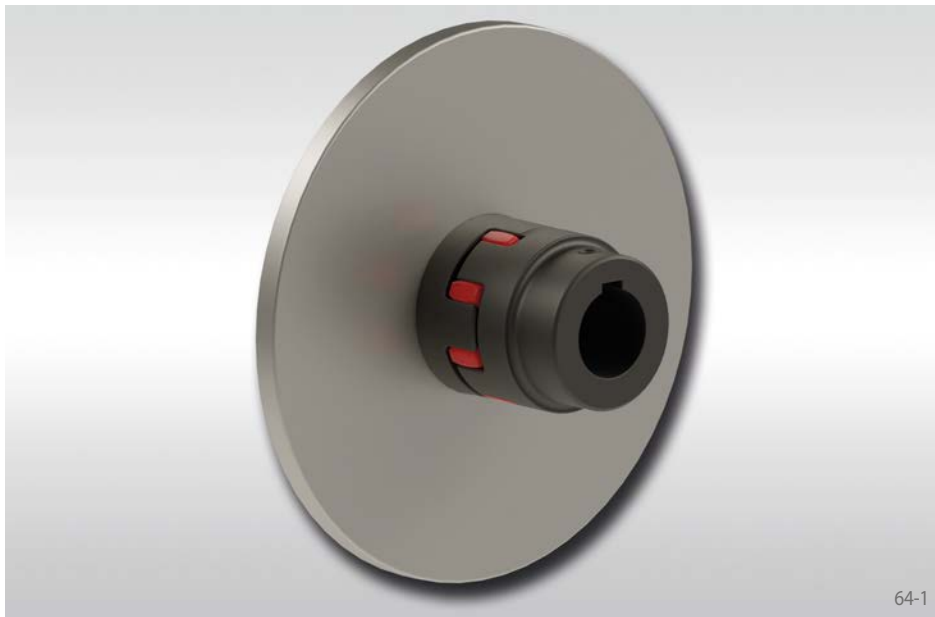

64-1

Features

- Compensation of axial, radial and angular misalignments
- Coupling and brake discs matched to RINGSPANN brake systems
- Adsorbs vibrations
- Fail-safe in the event of the failure of the spider
- Maintenance free, no lubrication necessary
- Blind assembly possible
- Symmetrical design allows for high running speeds without additional balancing
- Typical application: Ventilator drives, crane trolleys, machine tools, conveyor belts

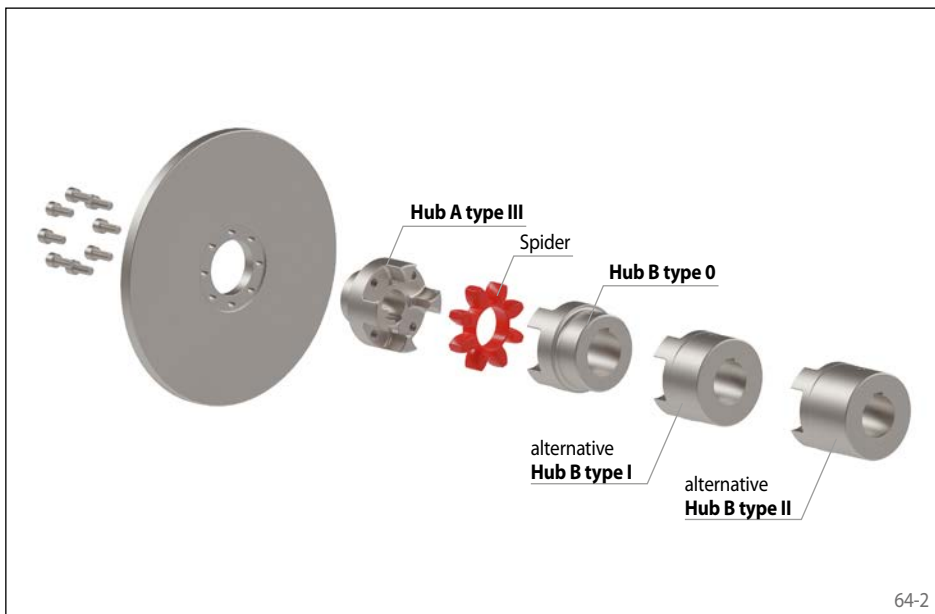

64-2

Order example

Order example	Code
Coupling design	REK
Coupling size	0038
Type	DCS
Material of the hub:	STA
• Steel	
Hub A, type:	
• III, with brake disc, standard	3
• IV, with brake disc, extended	4
Hub A, design:	
• finish bored with keyway	FB
• roughbored	VA
Bore diameter hub A	028
Hub B, type:	
• 0, standard	0
• I, increased max. bore	1
• II, extended, increased max. bore	2
Hub B, design:	
• finish bored with keyway	FB
• roughbored	VA
Bore diameter hub B	028
Spiders:	
• PU 92 Shore-A	PU92
• PU 95 Shore-A	PU95
• TU 92 Shore-A	TU92
• TU 98 Shore-A	TU98
• TU 65 Shore-D	TU65
Brake disc size and material*:	S0AA
Steel, 200 x 12,5 mm	

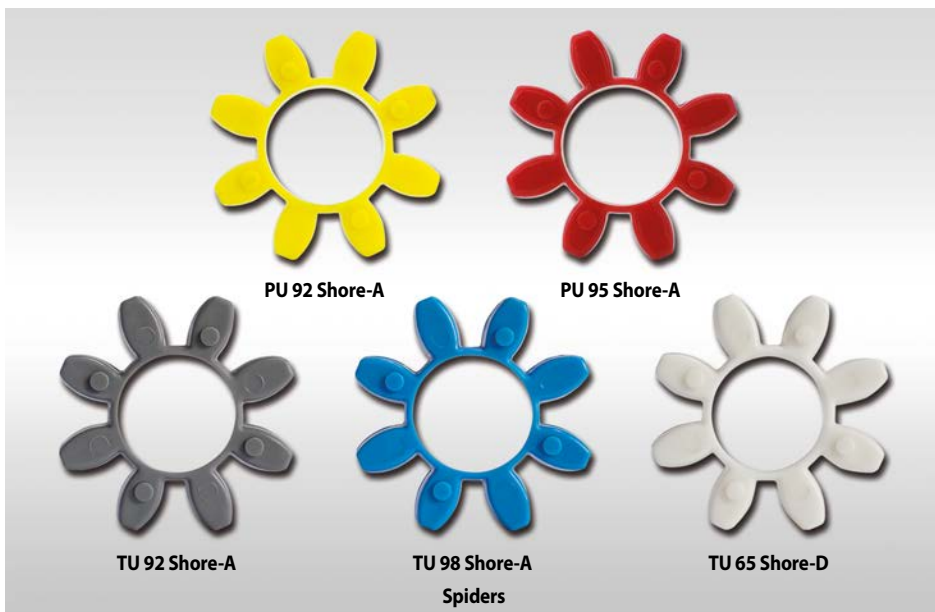

* see table "Brake discs and ordering code"

REK 0038 DCS-STA-3FB028-0FB028-PU92-S0AA

elastic for dynamic applications
with curved jaws and brake disc

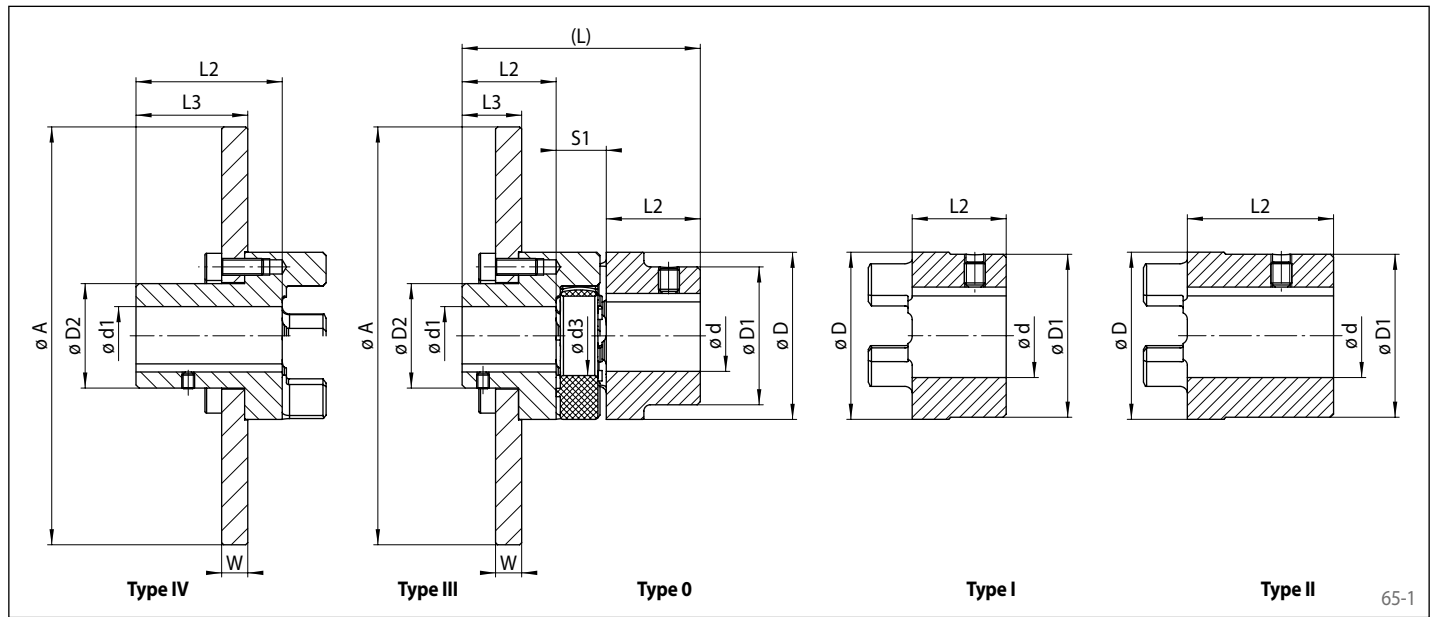

Coupling size*	Max. speed n_{max} min ⁻¹	Pilot bore d/d1 mm	Min. bore d/d1 mm	Max. bore d Hub type 0, I + II mm	Max. bore d1 Hub type III + IV (with brake disc) mm	d3 mm	D mm	D1		D2 mm	L2		L3		S1 min. mm	Permissible misalignments		
								Hub type 0 mm	Hub type I + II mm		Hub type III + IV mm	Hub type 0 / I / III mm	Hub type II + IV mm	Hub type III mm		Hub type IV mm	Axial mm	Radial mm
0038	9500	10	12	48	34	38	80	66	78	50	45	70	39,5	64,5	24	2,2	0,25	0,9
0042	8000	12	14	55	42	46	95	75	94	60	50	75	42,5	67,5	26	2,3	0,30	0,9
0048	7200	13	15	62	48	51	105	85	104	68	56	80	47,5	71,5	28	3,0	0,35	1,0
0055	6350	18	20	74	55	60	120	98	118	78	65	90	53,5	79,5	30	3,0	0,35	1,0
0065	5650	20	22	80	65	68	135	115	133	92	75	100	62,5	87,5	35	3,5	0,40	1,0
0075	4750	28	30	95	75	80	160	135	158	106	85	110	70,5	85,5	40	3,5	0,45	1,1
0090	3800	38	40	110	100	100	200	160	198	140	100	125	82,5	102,5	45	4,5	0,50	1,1

* Design of the hub in steel

Brake discs and ordering code

Material	$\phi A \times W$ mm	Max. speed n_{max} min ⁻¹	Coupling size									
			0038	0042	0048	0055	0065	0075	0090			
Steel	200 x 12,5	9100	S0AA									
	250 x 12,5	7300	S0BA	S0BA	S0BA							
	250 x 20	7300			S0BC*							
	315 x 16	5700		S0DB	S0DB	S0DB	S0DB	S0DB	S0DB			
	315 x 20	5700				S0DC*						
	355 x 30	5100					S0EE*					
	400 x 16	4500			S0FB	S0FB	S0FB	S0FB	S0FB	S0FB	S0FB	S0FB
	400 x 30	4500					S0FE	S0FE	S0FE	S0FE	S0FE	S0FE
	450 x 30	4000						S0HE	S0HE	S0HE	S0HE	S0HE
	500 x 16	3600				S0IB	S0IB	S0IB	S0IB	S0IB	S0IB	S0IB
	500 x 30	3600						S0IE	S0IE	S0IE	S0IE	S0IE
	560 x 30	3200									S0KE*	S0KE*
	630 x 20	2900						S0LC	S0LC	S0LC	S0LC	S0LC
710 x 20	2600						S0MC	S0MC	S0MC	S0MC	S0MC	
800 x 25	2300										S0ND*	
Nodular cast iron GGG 50	200 x 12,5	9100	G0AA									
	250 x 12,5	7300	G0BA	G0BA	G0BA							
	300 x 12,5	6000		G0CA	G0CA	G0CA	G0CA	G0CA	G0CA	G0CA	G0CA	G0CA
	355 x 12,5	5100		G0EA	G0EA	G0EA	G0EA	G0EA	G0EA	G0EA	G0EA	G0EA
	430 x 12,5	4200				G0GA	G0GA	G0GA	G0GA	G0GA	G0GA	G0GA
	520 x 12,5	3500				G0JA	G0JA	G0JA	G0JA	G0JA	G0JA	G0JA
	630 x 25	2900								G0LD	G0LD	G0LD
	710 x 25	2600								G0MD	G0MD	G0MD
800 x 25	2300									G0ND	G0ND	

* Brake disc sizes on request

Spiders

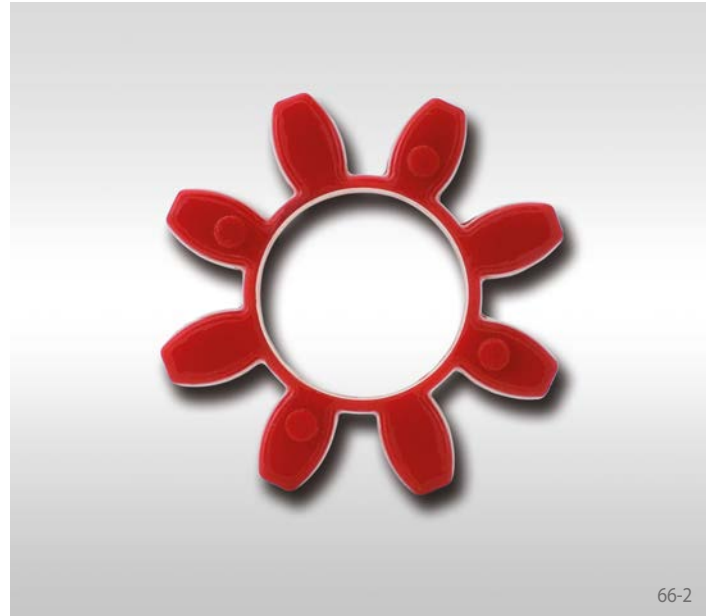
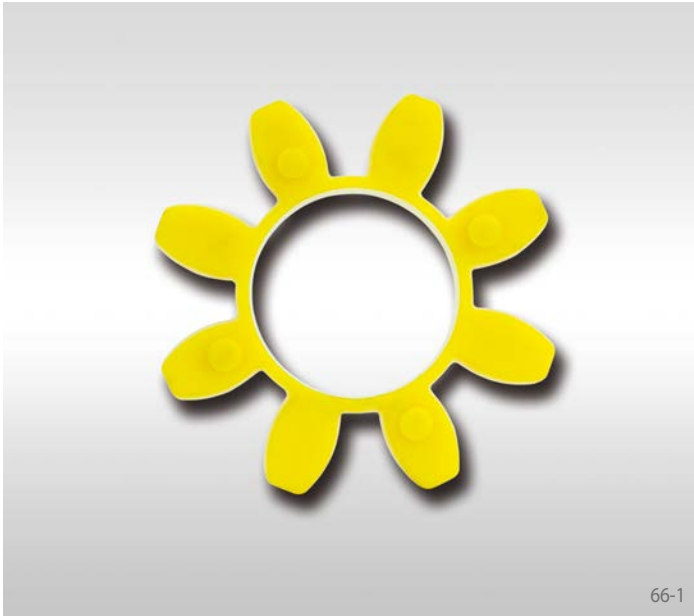

Spider PU 92 Shore-A

Material: Polyurethane
 Hardness: 92 ±2 Shore-A
 Temperature range: -30 °C to +80 °C
 Colour: yellow

Spider PU 95 Shore-A

Material: Polyurethane
 Hardness: 95 ±2 Shore-A
 Temperature range: -30 °C to +90 °C
 Colour: red

Coupling size	Nominal torque T_{KN} Nm	Nominal power at 100 min^{-1} P_{K100} kW	Max. torque $T_{K \max}$ Nm	Alternating torque T_{KW} Nm	Torsional stiffness $C_{T \text{ dyn}}$ Nm/rad x 10^3			Relative damping ψ at 0,5 T_{KN}
					1,0 T_{KN}	0,5 T_{KN}	0,25 T_{KN}	
0038	181	1,9	372	48	10,2	6,7	4,6	0,9
0042	253	2,6	510	67	14,4	9,4	6,5	
0048	296	3,1	600	79	16,6	10,9	7,5	
0055	392	4,1	800	105	22,9	15,0	10,4	
0065	590	6,3	1220	160	26,0	19,3	13,9	
0075	1220	12,8	2500	326	54,4	40,4	29,0	
0090	2290	24,0	4700	610	86,7	64,0	47,0	

Coupling size	Nominal torque T_{KN} Nm	Nominal power at 100 min^{-1} P_{K100} kW	Max. torque $T_{K \max}$ Nm	Alternating torque T_{KW} Nm	Torsional stiffness $C_{T \text{ dyn}}$ Nm/rad x 10^3			Relative damping ψ at 0,5 T_{KN}
					1,0 T_{KN}	0,5 T_{KN}	0,25 T_{KN}	
0038	310	3,2	610	81,0	24,0	16,2	10,6	0,9
0042	430	4,5	850	111	33,9	22,9	12,3	
0048	500	5,2	990	130	39,2	26,4	16,9	
0055	650	6,8	1300	169	53,9	36,4	25,3	
0065	890	9,4	1780	232	69,3	47,6	33,3	
0075	1830	19,2	3640	474	84,6	58,9	41,4	
0090	3430	36,0	6800	889	150,9	118,5	85,5	

Spiders

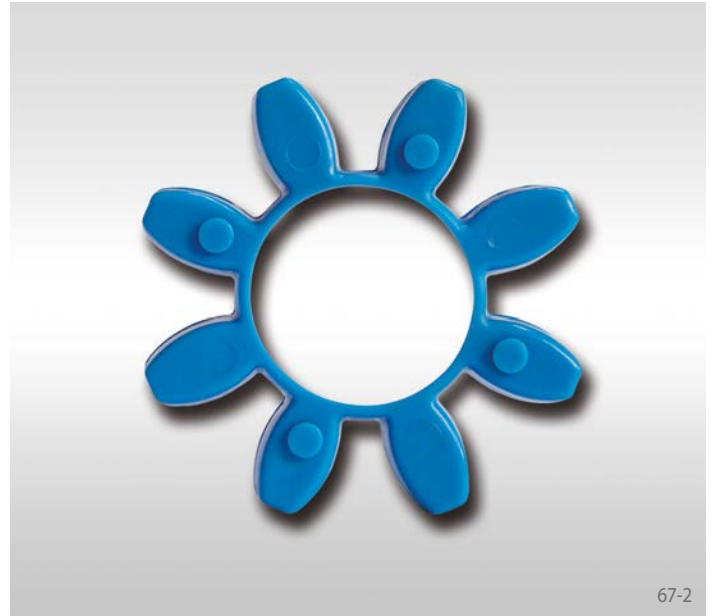

Spider TU 92 Shore-A

Material: Polyurethane
 Hardness: 92 ±2 Shore-A
 Temperature range: -30 °C to +120 °C
 Colour: grey

Spider TU 98 Shore-A

Material: Polyurethane
 Hardness: 98 ±2 Shore-A
 Temperature range: -30 °C to +120 °C
 Colour: blue

Coupling size	Nominal torque T_{KN} Nm	Nominal power at 100 min^{-1} P_{K100} kW	Max. torque $T_{K \max}$ Nm	Alternating torque T_{KW} Nm	Torsional stiffness $C_{T \text{ dyn}}$ Nm/rad x 10^3			Relative damping ψ at 0,5 T_{KN}
					1,0	0,5	0,25	
					T_{KN}	T_{KN}	T_{KN}	
0038	181	1,9	372	48	9,80	6,42	4,59	0,9
0042	253	2,6	510	67	15,41	10,37	7,39	
0048	296	3,1	600	79	17,82	11,99	8,55	
0055	392	4,1	800	105	24,51	16,50	11,76	
0065	590	6,2	1220	160	40,37	27,75	19,75	
0075	1220	12,8	2500	326	84,55	58,11	41,36	
0090	2290	24	4700	610	158,74	109,11	77,65	

Coupling size	Nominal torque T_{KN} Nm	Nominal power at 100 min^{-1} P_{K100} kW	Max. torque $T_{K \max}$ Nm	Alternating torque T_{KW} Nm	Torsional stiffness $C_{T \text{ dyn}}$ Nm/rad x 10^3			Relative damping ψ at 0,5 T_{KN}
					1,0	0,5	0,25	
					T_{KN}	T_{KN}	T_{KN}	
0038	332	3,5	664	83,00	30,89	22,41	15,54	0,9
0042	477	5,0	954	119,25	45,49	33,16	22,98	
0048	525	5,5	1050	131,25	52,25	38,09	26,39	
0055	694	7,3	1388	173,50	70,55	51,44	35,64	
0065	973	10,2	1946	243,25	100,65	73,71	51,04	
0075	1980	20,7	3960	495,00	209,61	153,50	106,29	
0090	3523	36,9	7046	880,75	413,38	272,95	134,19	

Spiders



Spider TU 65 Shore-D

Material: Polyurethane
 Hardness: 65 ±2 Shore-D
 Temperature range: -30 °C to +120 °C
 Colour: white

Coupling size	Nominal torque T_{KN} Nm	Nominal power at 100 min^{-1} P_{K100} kW	Max. torque T_{Kmax} Nm	Alternating torque T_{KW} Nm	Torsional stiffness $C_{T \text{ dyn}}$ Nm/rad x 10^3			Relative damping ψ at 0,5 T_{KN}
					1,0 T_{KN}	0,5 T_{KN}	0,25 T_{KN}	
0038	402	4,2	804	100,50	38,14	22,41	15,54	1,0
0042	560	5,9	1 120	140,00	60,36	45,49	29,75	
0048	667	7,0	1 334	166,75	71,04	53,54	35,01	
0055	834	8,7	1 668	208,50	92,27	69,54	45,47	
0065	1 155	12,1	2 310	288,75	141,08	102,45	59,79	
0075	2 380	24,9	4 760	595,00	294,43	213,82	124,77	
0090	4 514	47,3	9 028	1 128,50	550,50	338,37	183,26	

Coupling selection

The selection of the coupling is carried out in accordance with DIN 740 part 2 or with the help of service factors due to experience (see table: Assignment of the selection method to coupling types). The coupling must be designed in such a manner that the permissible coupling

stress is not exceeded in any operating state. A comparison of the occurring stresses with the permissible coupling parameters must be carried out for this purpose.

In addition to the selection of the coupling, the load-bearing capacity of the selected Shaft-Hub-Connection must be examined by the customer.

Assignment of the selection method to coupling types

Torsionally Rigid Shaft Couplings	Selection according to DIN 740 part 2	Selection with service factors
Gear Couplings		
RDZ ... DTO		●
RDZ ... DFO		●
RDZ ... EEO	●	
Disc Couplings		
RDL ... DSO		●
RDL ... DSZ		●
RDL ... DSA		●
Flexible Couplings		
RDA ... ESO, Design RDA ... ESO-...-0...		●
RDA ... ESO, Design RDA ... ESO-STA-1KA ...		●
RDA ... ESO, Design RDA ... ESO-GJS-2PE ...		●
Elastic Shaft Couplings	Selection according to DIN 740 part 2	Selection with service factors
Grid Couplings		
RES ... EYO		●
RES ... ETO		●
Pin and Bush Couplings		
REB ... DCO	●	
REB ... DCS	●	
Jaw Couplings		
REK ... DGO	●	
REK ... DHO	●	
REK ... DGZ	●	
REK ... DCO	●	
REK ... DCS	●	

Formula symbols

J_A = Moment of inertia of the drive side [kgm²]

J_L = Moment of inertia of the load side [kgm²]

M_A = Rotational inertia factor of the drive side

M_L = Rotational inertia factor of the load side

N = Speed of the machine [min⁻¹]

P_{AN} = Nominal power of the drive [kW]

P_{LN} = Power consumption of driven machine [kW]

P_N = Nominal power $P_N = P_{AN}$ or P_{LN} [kW]

S_{A, S_L} = Co-efficient of impact

S_B = Service factor

S_t = Temperature factor

S_Z = Start-up factor

T_{AS} = Peak torque of the drive side [Nm]

T_{Kmax} = Maximum permissible torque of the coupling [Nm]

T_{KN} = Nominal torque of the coupling [Nm]

T_{kW} = Alternating torque of the coupling [Nm]

T_{LS} = Peak torque of the load side [Nm]

T_N = Nominal torque of the machine [Nm]

T_S = Peak torque of the machine [Nm]

T_W = Alternating torque of the machine [Nm]

Design as per DIN 740 part 2

a) Drives without periodic stress due to torsional vibration

For drives without periodic stress due to torsional vibration such as centrifugal pumps, ventilators, screw compressors and similar applications, the nominal torque of the machine T_N may not exceed the nominal torque of coupling T_{KN} .

1. Stress from the nominal torque of the machine

The nominal torque of the machine T_N results from:

$$T_N = 9550 \cdot \frac{P_N}{n}$$

With consideration of the temperature factor S_t , the nominal torque of coupling T_{KN} must be at least as high as the nominal torque of machine T_N .

$$T_{KN} \geq T_N \cdot S_t$$

2. Additional stress through torque shocks

If shock loads occur often in the machine, the additional peak torque T_S and the shock frequency S_Z must be factored in.

Depending on the shock type, the shock direction and the mass distribution, the peak torque T_S can be calculated as follows:

Drive-side shock:

$$T_S = T_{AS} \cdot M_A \cdot S_A$$

Load-side shock:

$$T_S = T_{LS} \cdot M_L \cdot S_L$$

with

$$M_A = \frac{J_L}{J_A + J_L} \quad M_L = \frac{J_A}{J_A + J_L}$$

The maximum permissible torque of coupling $T_{K \max}$ must be larger than the sum of peak torque T_S multiplied by the start-up factor S_Z and the nominal torque of the machine T_N with consideration of the temperature factor S_t .

$$T_{K \max} \geq T_S \cdot S_Z \cdot S_t + T_N \cdot S_t$$

For drives with A.C. motors and large, load-side masses, the start-up peak torque should be calculated with the help of suitable simulation methods.

b) Drives with periodic stress due to torsional vibration

Drives where torsional vibration can occur (e.g. diesel motors, piston compressors, piston pumps, etc.), the torques seen by the coupling can be determined through a rotational vibration analysis of the entire system. This requires among other things knowledge of the rotating masses, the rotational rigidity and all the excitation movements that occur in the system. In many cases, a vibrational calculation is too time consuming or you may not have all the necessary data in the configuration phase available. In this case, an approximate design can be carried out on the basis of the following criteria:

1. Stress through the unit torque

Using the temperature factor S_t , the nominal torque of the coupling T_{KN} must be at least as high as the nominal torque of the machine T_N .

$$T_{KN} \geq T_N \cdot S_t$$

2. Stress through an alternating torque

The periodic alternating torque of the machine T_W may at operating speed and using the temperature factor S_t may not exceed the permissible alternating torque of the coupling T_{KW} .

$$T_{KW} \geq T_W \cdot S_t$$

3. Stress when passing through harmonic resonance

If the harmonic resonance is passed through during operation, the hereby occurring peak torque T_S with consideration of the ambient temperature S_t may not exceed the maximum permissible torque of coupling $T_{K \max}$.

$$T_{K \max} \geq T_S \cdot S_t$$

Start-up factor S_Z

Start-up frequency/h	100	200	400	800
S_Z	1,0	1,2	1,4	1,6

Co-efficient of impact S_A/S_L

Co-efficient of impact	light impacts	medium impacts	heavy impacts
S_A/S_L	1,5	1,8	2,5

Temperature factor S_t

Ambient temperature T_a	-50 °C ≤ -30 °C	-30 °C < T_a ≤ +30 °C	+30 °C < T_a ≤ +40 °C	+40 °C < T_a ≤ +50 °C	+50 °C < T_a ≤ +60 °C	+60 °C < T_a ≤ +70 °C	+70 °C < T_a ≤ +80 °C	+80 °C < T_a ≤ +90 °C	+90 °C < T_a ≤ +100 °C	+100 °C < T_a ≤ +110 °C	+110 °C < T_a ≤ +120 °C
PU 92 Shore A	-	1	1,2	1,3	1,4	1,55	1,8	-	-	-	-
PU 95 Shore A	-	1	1,2	1,3	1,4	1,55	1,8	-	-	-	-
Htrans	-	1	1,2	1,3	1,4	1,55	1,8	-	-	-	-
TU 92 Shore-A	1	1	1,1	1,2	1,3	1,45	1,6	1,8	2,1	2,5	3
TU 98 Shore-A	1	1	1,1	1,2	1,3	1,45	1,6	1,8	2,1	2,5	3
TU 65 Shore-D	1	1	1,1	1,2	1,3	1,45	1,6	1,8	2,1	2,5	3
NBR 80 Shore A	-	1	1	1	1	1	1	-	-	-	-
NBR 75 Shore A	-	1	1	1	1	1	1	-	-	-	-
NR 80 Shore A	1,1	1	1	1	1	1	1	-	-	-	-
PA 6.6	-	1	1,15	1,25	1,4	1,6	1,9	2,3	3	-	-

Design with service factors

The permissible nominal torque of coupling T_{KN} must be at least as high as the nominal torque of the machine T_N with consideration of the operating conditions (service factor S_B).

$$T_{KN} \geq T_N \cdot S_B$$

The nominal torque of the machine T_N results is determined as follows

$$T_N = 9550 \cdot \frac{P_N}{n}$$

n = Speed of the machine [min^{-1}]

P_N = Nominal power [kW]

T_{KN} = Nominal torque of the coupling [Nm]

T_N = Nominal torque of the machine [Nm]

Service factor S_B

Machine	Individual applications	Service factor
Agitators	Pure liquids	1.0
	Mixtures of liquids of different densities	1.0
Blowers	Centrifugal	1.0
	Lobe	1.2
Can Filling Machines		1.0
Car Dumpers		2.0
Car Pullers, Intermittent Duty		1.5
Compressors	Centrifugal	1.0
	Reciprocating	2.2
Conveyors, Uniformly	Assembly	1.2
	Belt	1.2
Conveyors, Heavy Duty Not Uniformly	Fed assembly, automation technology	1.5
	Belt, uneven loading	1.5
	Oven feed	1.5
	Reciprocating	2.0
	Screw	1.5
	Shaker	1.5
	Bucket elevator	1.5
	Cranes and Hoists*	Main hoists
Trolley drive		2.0
Bridge drive		2.0
Crushers	Ore	3.0
	Stone	3.0
Dredges	Conveyors	2.0
	Cutter head drives	2.0
	Maneuvering winches	2.0
	Pumps	2.0
Fans	Centrifugal	1.0
	Forced draft	1.5
	Induced draft	1.25
	Cooling towers	1.5
Feeders	Screw	1.5
Generators	Not welding	1.0
	Welding	1.5
Hammer Mills		2.0
Laundry Washers	With reversing	1.5
Lumber Industry	Barkers: drum type	2.0
	Edger feed	2.0
	Live rolls	2.0
	Log haul: incline	2.0
	Log haul: well type	2.0
	Off bearing rolls	2.0
	Planer feed chains	1.75
	Planer tilting hoist	1.75
	Planer floor chains	1.75
	Slab conveyor	1.5
Sorting table	1.5	
Trimmer feed	1.5	

* Unless other values are required by law.

Machine	Individual applications	Service factor
Machine Tools	Bending roll	2.0
	Punch press, gear driven	2.0
	Tapping machines	2.0
	Main drives	1.5
Metal Mills	Auxiliary drives	1.5
	Draw bench - carriage	2.0
	Draw bench - main drive	2.0
Metal Rolling Mills	Forming machines	2.0
	Slitters	1.5
	Blooming mills	2.5
	Coilers, hot mill	2.0
	Coilers, cold mill	1.5
	Cold mills	2.0
	Cooling beds	1.75
	Door openers	2.0
	Draw benches	2.0
	Edger drives	1.75
Feed rolls, reversing mills	3.5	
	Furnace pushers	2.5
	Hot mills	3.0
	Ingot cars	2.5
	Kick-outs	2.5
	Manipulators	3.0
	Merchant mills	3.0
	Piercers	3.0
	Pusher rams	2.5
	Reel drives	1.75
	Reel drums	2.0
	Reelers	3.0
	Rod and bar mills	3.0
	Roughing mill delivery table	3.0
Runout tables	2.5	
Saws, hot & cold	2.5	
Screwdown drives	3.0	
Skelp mills	3.0	
Slitters / longitudinal cutting machine	3.0	
Slabbing mills	1.75	
Soaking pit cover drives	3.0	
Straighteners	2.5	
Tables, transfer & runout	2.5	
Thrust block	3.0	
Traction drive	3.0	
Tube conveyor rolls	2.5	
Unscramblers	2.5	
Wire drawing	1.75	
Mills, Rotary Type	Ball mill	2.25
	Tube dryers & coolers	2.0
	Hammer mill	1.75
	Kilns	2.0
	Pebble & rod	2.0
	Clay mixer, kneading mill, pug mill, continuous mixer	1.75
	Drum mill, grinding drum, deburring barrel, drum polishing machine	2.0

Machine	Individual applications	Service factor
Table Conveyors	Non-Reversing	2.25
	Reversing	2.5
	Wire drawing & flattening machine	2.0
	Wire winding machine	1.75
Mixers	Concrete mixers, continuous	1.5
	Concrete mixers, intermittent	2.0
Oil Industry	Oil well pumping	2.0
	Rotary kilns	2.0
Paper Mills	Agitators, mixers	1.5
	Barker auxiliaries, hydraulic	2.0
	Barker mechanical	2.0
	Pulper, beater, disc refiner	1.75
	Bleacher	1.0
	Calenders	2.0
	Calenders	1.5
	Chippers	2.5
	Coaters	1.0
	Converting Machines	In general, except cutters, platters
Conveyors		1.5
Couch roll		1.75
Cutters, platters		2.0
Cylinders		1.75
	Disc refiners	1.75
	Dryers	1.75
	Felt stretcher	1.25
	Felt whipper	2.0
	Jordans	1.75
	Line shaft	1.5
	Log haul	2.0
	Pulp grinder	1.75
	Press roll	2.0
	Reel	1.5
	Stock chests	1.5
	Suction roll	1.75
	Washers & thickeners	1.5
	Winders	1.5
	Printing presses	1.5
Pumps	Centrifugal	1.0
	Single acting 3 or more cylinders	1.5
Pumps, Reciprocating	Double acting 2 or more cylinders	2.0
	Vane	1.5
Rotary, Gear Type, Lobe		
Rubber Industry	Mixer	2.0
	Rubber calender	2.0
Screens	Rotary, stone or gravel	1.5
	Steering gear	1.0
	Stokers	1.0
Textile Industry	Dryers	1.5
	Dyeing machinery	1.5
	Windlass	2.0

Numeric value in order code for bore in imperial dimension

Bore and keyway according to AGMA 9002-C14, bore tolerance: interference fit

Bore, whole number	Bore, fractional															
	0	1/16"	1/8"	3/16"	1/4"	5/16"	3/8"	7/16"	1/2"	9/16"	5/8"	11/16"	3/4"	13/16"	7/8"	15/16"
0"	AAA	AAB	AAC	AAD	AAE	AAF	AAG	AAH	AAI	AAJ	AAK	AAL	AAM	AAN	AAO	AAP
1"	ABA	ABB	ABC	ABD	ABE	ABF	ABG	ABH	ABI	ABJ	ABK	ABL	ABM	ABN	ABO	ABP
2"	ACA	ACB	ACC	ACD	ACE	ACF	ACG	ACH	ACI	ACJ	ACK	ACL	ACM	ACN	ACO	ACP
3"	ADA	ADB	ADC	ADD	ADE	ADF	ADG	ADH	ADI	ADJ	ADK	ADL	ADM	ADN	ADO	ADP
4"	AEA	AEB	AEC	AED	AEE	AEF	AEG	AEH	AEI	AEJ	AEK	AEL	AEM	AEN	AEO	AEP
5"	AFA	AFB	AFC	AFD	AFE	AFF	AFG	AFH	AFI	AFJ	AFK	AFL	AFM	AFN	AFO	AFP
6"	AGA	AGB	AGC	AGD	AGE	AGF	AGG	AGH	AGI	AGJ	AGK	AGL	AGM	AGN	AGO	AGP
7"	AHA	AHB	AHC	AHD	AHE	AHF	AHG	AHH	AHI	AHJ	AHK	AHL	AHM	AHN	AHO	AHP
8"	AIA	AIB	AIC	AID	AIE	AIF	AIG	AIH	AIJ	AIJ	AIK	AIL	AIM	AIN	AIO	AIP
9"	AJA	AJB	AJC	AJD	AJE	AJF	AJG	AJH	AJI	AJJ	AJK	AJL	AJM	AJN	AJO	AJP
10"	AKA	AKB	AKC	AKD	AKE	AKF	AKG	AKH	AKI	AKJ	AKK	AKL	AKM	AKN	AKO	AKP
11"	ALA	ALB	ALC	ALD	ALE	ALF	ALG	ALH	ALI	ALJ	ALK	ALL	ALM	ALN	ALO	ALP
12"	AMA	AMB	AMC	AMD	AME	AMF	AMG	AMH	AMI	AMJ	AMK	AML	AMM	AMN	AMO	AMP
13"	ANA	ANB	ANC	AND	ANE	ANF	ANG	ANH	ANI	ANJ	ANK	ANL	ANM	ANN	ANO	ANP
14"	AOA	AOB	AOC	AOD	AOE	AOF	AOG	AOH	AOI	AOJ	AOK	AOL	AOM	AON	AOO	AOP
15"	APA	APB	APC	APD	APE	APF	APG	APH	API	APJ	APK	APL	APM	APN	APO	APP
16"	AQA	AQB	AQC	AQD	AQE	AQF	AQG	AQH	AQI	AQJ	AQK	AQL	AQM	AQN	AQO	AQP
17"	ARA	ARB	ARC	ARD	ARE	ARF	ARG	ARH	ARI	ARJ	ARK	ARL	ARM	ARN	ARO	ARP
18"	ASA	ASB	ASC	ASD	ASE	ASF	ASG	ASH	ASI	ASJ	ASK	ASL	ASM	ASN	ASO	ASP
19"	ATA	ATB	ATC	ATD	ATE	ATF	ATG	ATH	ATI	ATJ	ATK	ATL	ATM	ATN	ATO	ATP
20"	AUA	AUB	AUC	AUD	AUE	AUF	AUG	AUH	AUI	AUJ	AUK	AUL	AUM	AUN	AUO	AUP
21"	AVA	AVB	AVC	AVD	AVE	AVF	AVG	AVH	AVI	AVJ	AVK	AVL	AVM	AVN	AVO	AVP
22"	AWA	AWB	AWC	AWD	AWE	AWF	AWG	AWH	AWI	AWJ	AWK	AWL	AWM	AWN	AWO	AWP
23"	AXA	AXB	AXC	AXD	AXE	AXF	AXG	AXH	AXI	AXJ	AXK	AXL	AXM	AXN	AXO	AXP

Bore and keyway according to AGMA 9002-C14, bore tolerance: clearance fit

Bore, whole number	Bore, fractional															
	0	1/16"	1/8"	3/16"	1/4"	5/16"	3/8"	7/16"	1/2"	9/16"	5/8"	11/16"	3/4"	13/16"	7/8"	15/16"
0"	ZAA	ZAB	ZAC	ZAD	ZAE	ZAF	ZAG	ZAH	ZAI	ZAJ	ZAK	ZAL	ZAM	ZAN	ZAO	ZAP
1"	ZBA	ZBB	ZBC	ZBD	ZBE	ZBF	ZBG	ZBH	ZBI	ZBJ	ZBK	ZBL	ZBM	ZBN	ZBO	ZBP
2"	ZCA	ZCB	ZCC	ZCD	ZCE	ZCF	ZCG	ZCH	ZCI	ZCJ	ZCK	ZCL	ZCM	ZCN	ZCO	ZCP
3"	ZDA	ZDB	ZDC	ZDD	ZDE	ZDF	ZDG	ZDH	ZDI	ZDJ	ZDK	ZDL	ZDM	ZDN	ZDO	ZDP
4"	ZEA	ZEB	ZEC	ZED	ZEE	ZEF	ZEG	ZEH	ZEI	ZEJ	ZEK	ZEL	ZEM	ZEN	ZEO	ZEP
5"	ZFA	ZFB	ZFC	ZFD	ZFE	ZFF	ZFG	ZFH	ZFI	ZFJ	ZFK	ZFL	ZFM	ZFN	ZFO	ZFP
6"	ZGA	ZGB	ZGC	ZGD	ZGE	ZGF	ZGG	ZGH	ZGI	-	-	-	-	-	-	-

Inch bores

The RINGSPANN shaft couplings are also available with bores in inch dimensions.

RINGSPANN follows the specifications of AGMA 9002-C14 as of 02.2015. Deviating bores, e.g. according to B.S. 46, are possible, but must be requested separately. When ordering inch bores, RINGSPANN recommends specifying not only the bore diameter in inches or millimetres, but also the width and depth of the keyway and the desired fit.

On the next page you will find a selection of the most common bores with the dimensions of the keyways. Further bores can be requested from RINGSPANN.

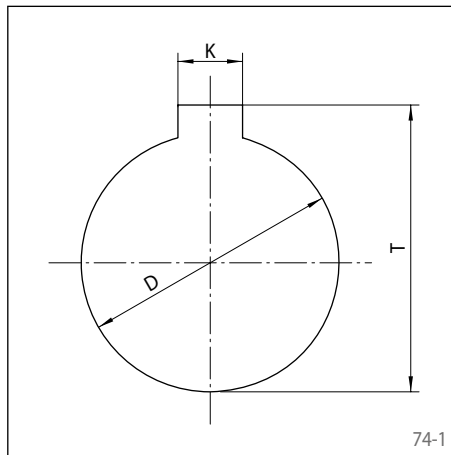

Inch bores

	Bore				Keyway							
	Nominal Shaft Diameter	Bore Diameter D	Bore Tolerance		Width K		Width K Tolerance mm	Depth T mm	Depth T Tolerance mm			
			AGMA Clearance Fit mm	AGMA Interference Fit mm	inch	mm						
Square key	3/8	9,525	-0,0000 / +0,0254	-0,0254 / -0,0127	3/32	2,38	-0,000 / +0,051	10,698	-0,000 / +0,381			
	7/16	11,113			1/8	3,18		12,309				
	1/2	12,700			3/16	4,76		14,221				
	5/8	15,875			1/4	6,35		18,026				
	3/4	19,050			5/16	7,94		21,262				
	15/16	23,813			3/8	9,53		26,690				
	1	25,400			1/2	12,70		28,306				
	1 1/4	31,750			-0,0508 / -0,0254	-0,0508 / -0,0254		5/8		15,88	-0,000 / +0,064	34,740
	1 3/8	34,925										62,921
	1 1/2	38,100										67,333
	1 5/8	41,275										70,564
	1 3/4	44,450										73,790
	1 15/16	49,213										77,008
	2	50,800										83,035
	2 1/4	57,150										84,651
	2 3/8	60,325			-0,0762 / -0,0381	-0,0762 / -0,0381		7/8		22,23	-0,000 / +0,076	91,095
	2 1/2	63,500	95,507									
	2 5/8	66,675	98,735									
	2 3/4	69,850	101,961									
	2 15/16	74,613	105,181									
	3	76,200	111,206									
	3 1/4	82,550	112,822									
	3 3/8	85,725	119,268									
	3 1/2	88,900	-0,0889 / -0,0508	-0,0889 / -0,0508	1	25,40	-0,000 / +0,089	122,489				
	3 5/8	92,075						125,705				
	3 3/4	95,250						131,298				
	3 15/16	100,013						134,534				
	4	101,600						139,380				
	4 1/4	107,950						140,993				
	4 3/8	111,125						147,442				
	4 1/2	114,300						150,663				
	4 5/8	117,475	-0,1016 / -0,0635	-0,1016 / -0,0635	1 1/4	31,75	-0,000 / +0,089	153,881				
4 3/4	120,650	159,474										
4 15/16	125,413	162,707										
5	127,000	167,551										
5 1/4	133,350	169,164										
5 3/8	136,525	175,616										
5 1/2	139,700	178,836										
5 5/8	142,875	182,057										
5 3/4	146,050	not spezified according ANSI / AGMA 9002-C14	-0,1016 / -0,0635	1 1/2	38,10	-0,000 / +0,102	184,470					
5 15/16	150,813						187,703					
6	152,400						194,163					
6 1/4	158,750						200,612					
6 3/8	161,925						207,056					
6 1/2	165,100						212,700					
6 5/8	168,275						219,159					
6 3/4	171,450						225,610					
7	177,800						232,054					
7 1/4	184,150						238,493					
7 1/2	190,500						244,927					
7 3/4	196,850						252,938					
8	203,200						259,408					
8 1/4	209,550						265,869					
8 1/2	215,900						272,326					
8 3/4	222,250						285,224					
9	228,600	291,666										
9 1/4	234,950	298,105										
9 1/2	241,300	312,577										
9 3/4	247,650	319,039										
10	254,000	325,496										
10 1/2	266,700	338,394										
10 3/4	273,050	344,838										
11	279,400	351,279										
11 1/2	292,100	368,922										
11 3/4	298,450	375,382										
12	304,800	381,838										
12 1/2	317,500	394,739										
12 3/4	323,850	401,185										
13	330,200	407,627										
13 1/2	342,900	425,267										
13 3/4	349,250	431,726										
14	355,600	438,183										
14 1/2	368,300	451,084										
14 3/4	374,650	457,530										
15	381,000											
15 1/2	393,700											
15 3/4	400,050											
16	406,400											
16 1/2	419,100											
16 3/4	425,450											

Questionnaire for selecting Tru-Line Flange-Couplings RFK ... TBO

Please photocopy or use the technical query from our website (www.ringspann.com)!

Company:	Phone:
Name:	E-Mail:
	Date:

1. Type of application

1.1 Machine type, machine group or drive:

2. Operating data

2.1 Performance data

Driving power	P_n	_____	[kW]
Max. shaft speed	n_M	_____	[min ⁻¹]
Nominal torque	M_N	_____	[Nm]
Max. torque	M_{max}	_____	[Nm]
Min. safety factor	S_{min}	_____	[1]
Max. bending moment	M_b	_____	[Nm]
Max. radial force	F_{rad}	_____	[N]
Max. axial force	F_{ax}	_____	[N]

2.2 Installation conditions

outside
 in a closed room

Ambient temperatures
 from _____ °C to _____ °C

2.3 Supplement

Please send us a description and drawing in the event of other installation conditions. We are happy to review them and provide recommendations.

3. Dimensions

3.1 Data of shaft

Shaft 1/Flange 1

Shaft diameter	d_1	_____	[mm]
Shaft material		_____	
Shaft tolerance	T_{1W}	_____	[mm]
Average surface roughness	R_{z1}	_____	[µm]

Shaft 2/Flange 2

Shaft diameter	d_2	_____	[mm]
Shaft material		_____	
Shaft tolerance	T_{2W}	_____	[mm]
Average surface roughness	R_{z2}	_____	[µm]

Drawing of the coupling with dimensions of the shaft ends

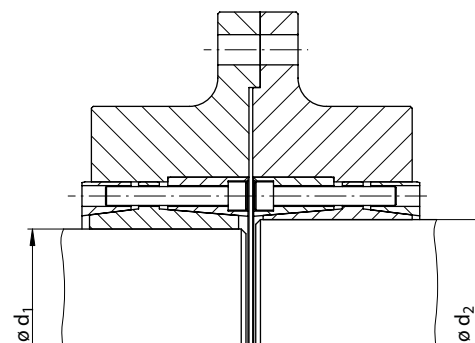

Questionnaire for selecting Tru-Line Flange-Couplings RFK ... TBO

Please photocopy or use the technical query from our website (www.ringspann.com)!

Company:

Phone:

Name:

E-Mail:

Date:

3.2 Data of rocker

Distance to torque support a _____ [mm]

e _____ [mm]

Angular γ _____ [°]

Total weight G_w _____ [kg]

Distance to bearing d _____ [mm]

Distance to centre of gravity b _____ [mm]

c _____ [mm]

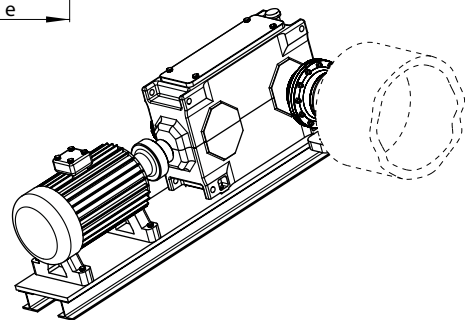
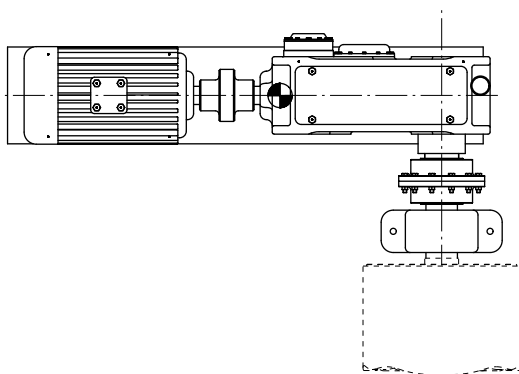
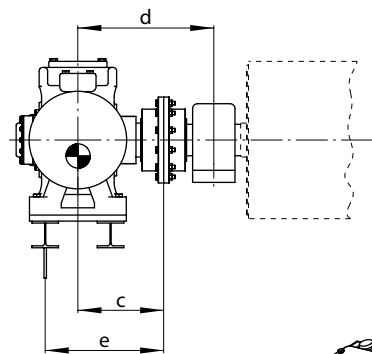
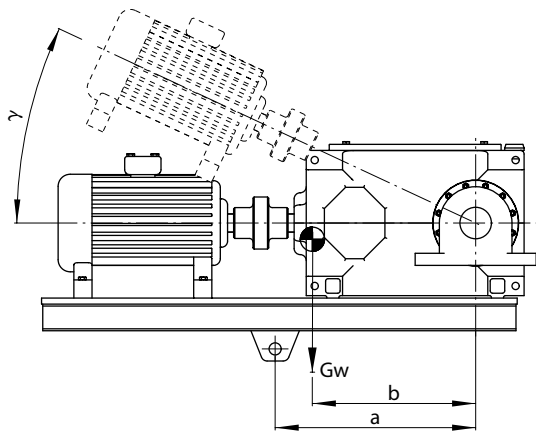

4. Estimated requirements _____ Piece (one-off)

_____ Piece/month

_____ Piece/year

5. Appendices

Specifications

Data sheet

Sketch/drawing

Please photocopy or use the technical query from our website (www.ringspann.com)!

Company:	Phone:
Name:	E-Mail:
	Date:

1. Type of application

1.1 Machine type, machine group or drive:

2. Operating data

2.1 Drive type

- Electric motor
- Combustion engine
 - Fuel type: Petrol
 - Diesel
 - Natural gas
 - Other:
- Number of cylinders:
- Gearbox
- Other:

Total torque of the application: _____ [Nm]

2.3 Operating data

- in a closed room
- outside, protected
- outside, sea air
- aggressive
- hazardous area, zone
- _____
- Other (accessibility, dusty atmosphere, etc.)
- _____

2.2 Performance data

Driving power: _____ [kW]

Speed of the drive / of the gearbox: _____ [min^{-1}]

Service factor S_B : _____

Ambient temperatures from _____ °C to _____ °C

3. Dimensions

3.1 Motor shaft

Cylindrical shaft with keyway

Diameter of the drive shaft: _____ [mm]

Keyway dimensions: _____ [mm]

Usable shaft length of the drive shaft: _____ [mm]

Please provide more details:
clearance fit, press fit, metric coupling size (P7, H7, etc.), with or without set screw, clamping elements / clamping sets

Special drive shaft
Specification

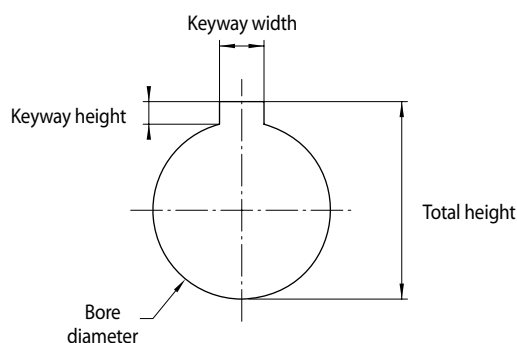

Please photocopy or use the technical query from our website (www.ringspann.com)!

Company:	Phone:
Name:	E-Mail:
	Date:

3.2 Output shaft

Cylindrical shaft with keyway

Diameter of the output shaft _____ [mm]

Keyway dimensions _____ [mm]

Usable shaft length of the output shaft _____ [mm]

Please provide more details:
clearance fit, press fit, metric coupling size (P7, H7, etc.), with or without set screw, clamping elements / clamping sets

Thread coupling size _____

Thread length _____ [mm]

Diameter of the spacer _____ [mm]

Thickness of the disc _____ [mm]

Special output shaft Specification

Taper shaft end

Min. diameter of the taper _____ [mm]

Max. diameter of the taper _____ [mm]

T (gradient) _____

Wrench size _____

3.3 Distances

Distance between the shaft ends _____ [mm]

Total installation length _____ [mm]

Please specify any obstacles, beams, protective grating, pipes, etc.

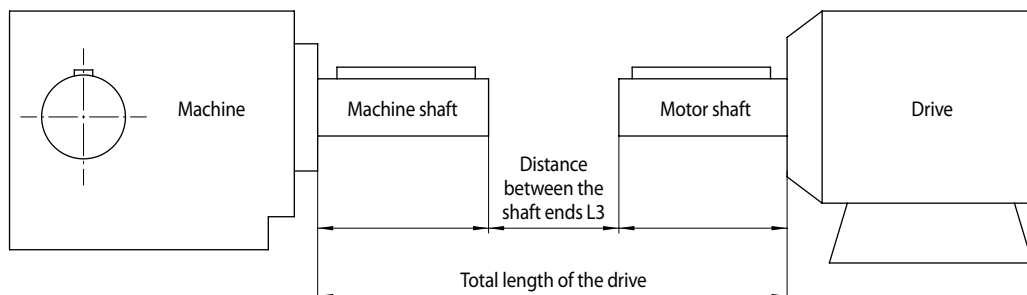

7. Estimated requirements

_____ Piece (one-off)

_____ Piece/month

_____ Piece/year

8. Appendices

Specifications

Data sheet

Sketch/drawing

Germany

RINGSPANN GmbH

Schaberweg 30-38, 61348 Bad Homburg
Germany • +49 6172 275 0
info@ringspann.de • www.ringspann.de

RINGSPANN Kempf GmbH

Moorstraße 4, 36129 Gersfeld (Rhön), Germany
+49 6654 9611 0 • info@ringspann-kempf.de
www.ringspann-kempf.de

RINGSPANN StS GmbH

Hansaring 6, 63843 Niedernberg, Germany
+49 6028 40642 0 • info@ringspann-sts.de
www.ringspann-sts.de

RINGSPANN RCS GmbH

Hans-Mess-Straße 7, 61440 Oberursel, Germany
+49 6172 67 68 50
info@ringspann-rcs.de • www.ringspann-rcs.de

**Bosnia and Herzegovina, Serbia,
Croatia, Montenegro, Kosovo,
North Macedonia, Albania**

RINGSPANN Bosanska Krupa d.o.o.

Radnicka bb, 77240 Bosanska Krupa, Bosnia and
Herzegovina • +387 37 961 444
info@ringspann.ba • www.ringspann.ba

France

RINGSPANN France S.A.

23 rue Saint-Simon, 69009 Lyon, France
+33 4 7883 5901
info@ringspann.fr • www.ringspann.fr

Great Britain, Ireland

RINGSPANN (U.K.) LTD.

3, Napier Road, Bedford MK41 0QS, Great Britain
+44 1234 3425 11
info@ringspann.co.uk • www.ringspann.co.uk

Italy

RINGSPANN Italia S.r.l.

Via A.D. Sacharov, 13, 20812 Limbiate (MB), Italy
+39 02 93 57 12 97
info@ringspann.it • www.ringspann.it

Netherlands, Belgium, Luxembourg

RINGSPANN Benelux B.V.

Nieuwenkampsmaten 6 - 15, 7472 DE Goor,
Netherlands • +31 547 26 13 55
info@ringspann.nl • www.ringspann.nl

Austria, Czech Republic,

Hungary, Slovakia, Slovenia

RINGSPANN Austria GmbH

Triesterstraße 21, 2620 Neunkirchen, Austria
+43 26 35 624 46
info@ringspann.at • www.ringspann.at

Poland

Radius-Radpol Wiecheć Sp.J.

Ul. Pasjonatów 3, 62-070 Dąbrowa, Poland
+48 61 814 39 28 • info@radius-radpol.com.pl
www.radius-radpol.com.pl

Romania, Bulgaria, Moldova

S.C. Industrial Seals and Rolls S.R.L.

Str. Depozitelor, No. 29, 110078 Pitesti, Romania
+4 0751 22 82 28
mihai@isar.com.ro • www.isar.com.ro

Sweden, Finland, Denmark,

Norway, Baltic states

RINGSPANN Nordic AB

Industrigatan 10A, 619 33 Trosa, Sweden
+49 6172 275 170
info@ringspann.se • www.ringspann.se

Switzerland

RINGSPANN AG

Sumpfstrasse 7, P.O. Box, 6303 Zug,
Switzerland • +41 41 748 0900
info@ringspann.ch • www.ringspann.ch

Spain, Portugal

RINGSPANN IBERICA S.A.

C/Uzbina, 24-Nave E1, 01015 Vitoria, Spain
+34 945 22 77-50
info@ringspann.es • www.ringspann.es

Turkey, Azerbaijan, Kazakhstan,

Kyrgyzstan, Tajikistan, Turkmenistan,

Uzbekistan

RINGSPANN Turkey Güç Aktarım**Sistemleri Ticaret Limited Şirketi**

Fatih Sultan Mehmet Mah, Poligon Cad. Buyaka 2
Sitesi 3 Blok No: 8 İç Kapı No: 1, 34771 Ümraniye /
Istanbul, Turkey • +90 532 165 7760
info@ringspann.tr • www.ringspann.tr

Ukraine

"START-UP" LLC.

Saltivske Hwy, 43, letter G-3, office 101,
Kharkiv 61038, Ukraine • +38 057 717 03 04
start-up@start-up.kh.ua • www.start-up.kh.ua

Asia

Australia, New Zealand

RINGSPANN Australia Pty Ltd

10 Network Drive, Carrum Downs Vic 3201,
Australia • +61 3 9069 0566
info@ringspann.com.au • www.ringspann.com.au

China, Taiwan

RINGSPANN Power Transmission (Tianjin) Co., Ltd.

No. 21 Gaoyan Rd., Binhai Science and Technology
Park, Binhai Hi-Tech Industrial, Development Area,
Tianjin, 300458, P.R. China • +86 22 5980 31 60
info.cn@ringspann.cn • www.ringspann.cn

India, Bangladesh, Nepal

RINGSPANN Power Transmission India Pvt. Ltd.

GAT No: 679/2/1, Village Kuruli, Taluka Khed, Chakan-
Alandi Road, Pune - 410501, Maharashtra, India
+91 21 35 67 75 00 • info@ringspann-india.com
www.ringspann-india.com

Singapore, ASEAN

RINGSPANN Singapore Pte. Ltd.

143 Cecil Street, #17-03 GB Building,
Singapore 069542 • +6012 589 8975
info@ringspann.sg • www.ringspann.sg

South Korea

RINGSPANN Korea Ltd.

33 Gojae-17 Ghil Dongnam-gu, 31187 Cheonan-si
Chungnam, South Korea • + 82 10 54961 368
info@ringspann.kr • www.ringspann.kr

America

Brazil

RINGSPANN do Brasil Ltda.

Rua Vereador Oclésio Antonio Rebutini, 480
CEP 13.287-012, Vinhedo/SP, Brazil
+55 97503 9323
contato@ringspann.com • www.ringspann.com.br

Chile, Peru, Colombia, Ecuador

RINGSPANN Sudamérica SpA

Isidora Goyenechea 3365, Piso 11, 8320000
Las Condes, Santiago-Región Metropolitana,
Chile • +56 9 9147 2833
info@ringspannsudamerica.com
www.ringspannsudamerica.com

USA, Canada, Mexico

RINGSPANN Corporation

10550 Anderson Place, Franklin Park, IL 60131, USA
+1 847 678 35 81
info@ringspann.us
www.ringspanncorp.com

Africa and Middle East

Egypt

Shofree Trading Co.

218 Emtedad Ramsis 2, 2775 Nasr City, Cairo, Egypt
+20 2 2081 2057
info@shofree.com • www.ringspann.com

Maghreb, West Africa

RINGSPANN France S.A.

23 rue Saint-Simon, 69009 Lyon, France
+33 4 7883 5901
info@ringspann.fr • www.ringspann.fr

Israel

Getter Group GG Yarom

4 Boltimor St., Petah Tikva, 4951015, Israel
+972 3 557 01 15
noam_a@gg.co.il • www.ringspann.com

South Africa, Sub-Saharan

RINGSPANN South Africa (Pty) Ltd.

96 Plane Road Spartan, Kempton Park,
P.O. Box 8111, Edenglen 1613, South Africa
+27 11 394 1830
info@ringspann.co.za • www.ringspann.co.za